

AK PLUS

Ferramenta per finestre - *Windows hardware*

- › Manuale di assemblaggio
Assembling manual

REVISIONI / UPDATES

La tabella sotto riportata elenca le ultime modifiche apportate al catalogo.
Eventuali aggiornamenti saranno pubblicati sul sito web.

Scansiona o clicca il QR code per consultare l'ultima versione.

The below index show the latest revisions.

Any updates will be published on the website.

Scan or click the QR code to download the latest version.



ULTIMA REVISIONE
LATEST UPDATE

VIDEO TUTORIAL



Scansiona il QR code per visualizzare il video di assemblaggio.

Scan the QR code to view the assembly video



VERSIONE VERSION	REVISIONE REVISION	DATA DATE	DESCRIZIONE DESCRIPTION	PAGINA PAGE
3	A	21/05/2026	Cambiata formula di taglio aste verticali (per la condizione con Gearbox) <i>The cutting formula of vertical rods has been changed (for the Gearbox config.)</i>	10.7_07
		02/04/2026	Aggiornato e modificato il montaggio del codice H48538 <i>The assembly of code H48538 has been updated and modified</i>	10.9_01-02-12
		05/03/2026	Aggiornamento pagine con l'inserimento delle serie C45-55K NI <i>Updating pages with the addition of C45-55K NI series</i>	Intero manuale <i>Complete manual</i>
		01/12/2025	Corretto il codice della cerniera (era H48232 invece del corretto H48323) <i>The hinge code has been corrected (it was H48232 instead of the H48323)</i>	10.08_06-07-08
2	C	02.04.2025	Modificata quota di posizionamento incontro era 116, ora è 136 <i>Changed strikers placement, from 116 to 136</i>	10.2.3
2	B	07.02.2025	Inserita nota (asola su asta macchinetta stulp, per incontro intermedio) <i>Inserted note (drawing stulp rod slot for intermediate striker)</i>	10.6.3
2	A	17.01.2025	Aggiornamenti vari <i>Various improvements</i>	Intero manuale <i>Complete manual</i>
		25.11.2024	Corretto il taglio aste <i>Corrected cutting rods</i>	10.6.3
1	A	31.10.2024	Prima emissione <i>First issue</i>	Intero manuale <i>Complete manual</i>

Le informazioni contenute in questi disegni sono di proprietà intellettuale esclusiva di AluK S.A.

Possono essere utilizzate al solo scopo per cui sono state fornite e non devono essere riprodotte, memorizzate o diffuse a terzi in qualsiasi modo o forma senza il permesso scritto di AluK S.A.

La politica AluK S.A. di miglioramento continuo determina il diritto di apportare modifiche senza preavviso.

Information contained in this drawing is the exclusive intellectual property of AluK S.A.

It may only be used for the purpose to which it has been supplied and must not be reproduced, stored or disseminated to third parties in any way or form without the prior written permissions of AluK S.A.

The AluK S.A. policy of continuous improvement determines the right to make the modifications without prior warning.

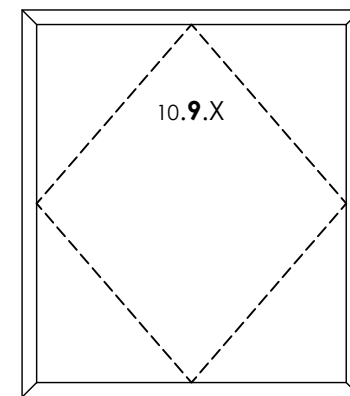
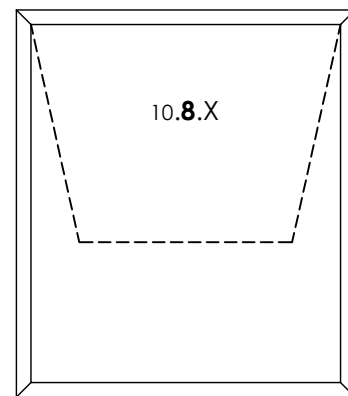
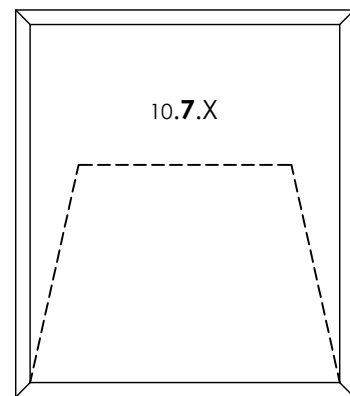
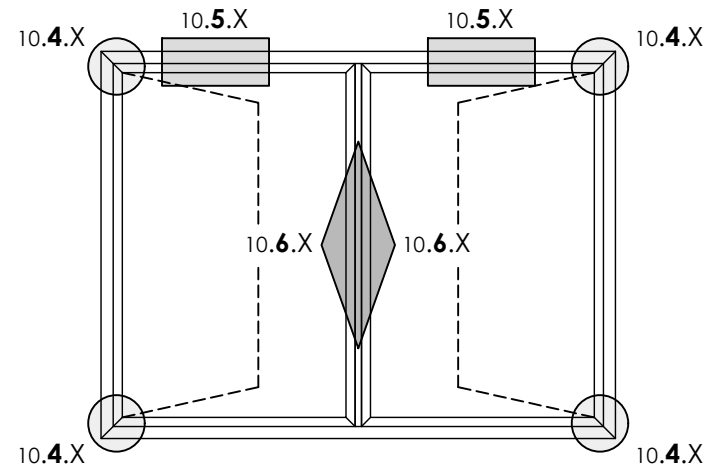
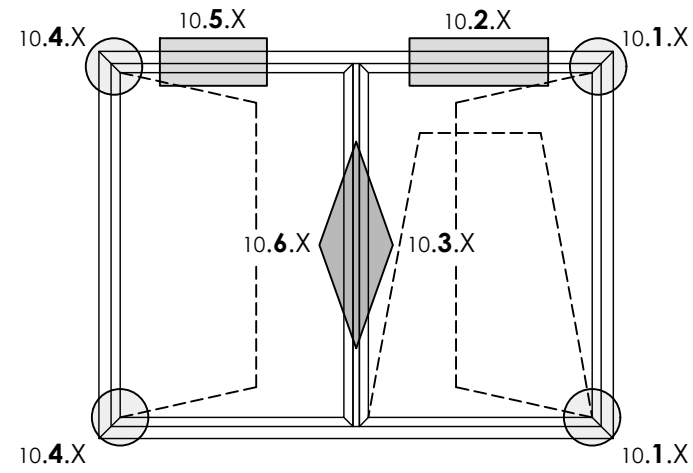
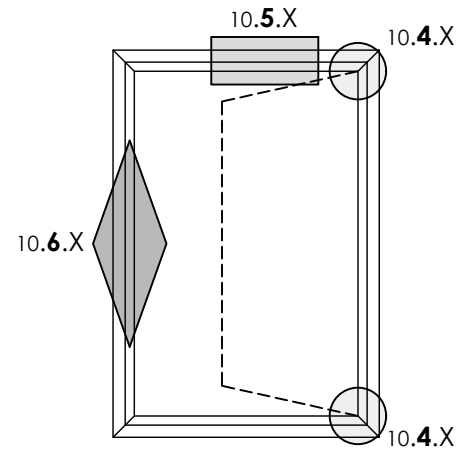
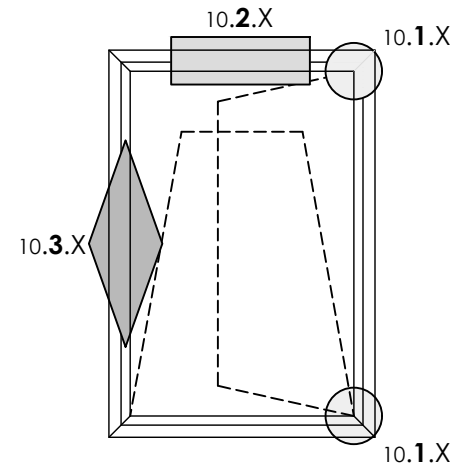

SOMMARIO

10.1.X	Cerniera anta ribalta
10.2.X	Braccio AR (cerniera visibile)
10.3.X	Kit base
10.4.X	Cerniera battente
10.5.X	Braccio cerniera battente (opzionale)
10.6.X	Kit chiusura anta e due ante
10.7.X	Vasistas
10.8.X	Sporgere
10.9.X	Bilico

SUMMARY

10.1.X	Turn & tilt hinge
10.2.X	Turn & tilt top arm (visible hinge)
10.3.X	Standard hardware kit
10.4.X	Turn-only hinge
10.5.X	Turn-only false arm (optional)
10.6.X	Single and double sash locking kit
10.7.X	Vasistas
10.8.X	Top hung
10.9.X	Pivot window

➤ ATTREZZATURE - TOOLS





IMMAGINE IMAGE	CODICE CODE	DESCRIZIONE DESCRIPTION	C67K	C77K	C77K-CS	C67K-IM
	T10017	Dima posizionamento braccio cerniera C180 <i>Template arm position for hinge C180</i>	●	●	●	●
		U.V. 1				
	T10099	Dima di foratura cerniere A/R HD <i>Drilling jig for T&T hinge</i>	●	●		
		U.V. 1				
	T10101	Dima di foratura cerniere A/R <i>Drilling jig for T&T hinge</i>	●	●	●	●
		U.V. 1				
	T10110	Dima di foratura bracci <i>Arm drilling jig</i>	●	●	●	●
		U.V. 1				
	T10111	Dima di montaggio incontri A/R <i>T&T striker positioning jig</i>	●	●	●	●
		U.V. 1				
	T10117	Dima di foratura asta <i>Rod drilling jig</i>	●	●	●	●
		U.V. 1				

IMMAGINE IMAGE	CODICE CODE	DESCRIZIONE DESCRIPTION

SEQUENZA MONTAGGIO APPARECCHIATURA ANTA RIBALTA
 TURN & TILT ASSEMBLING SEQUENCE

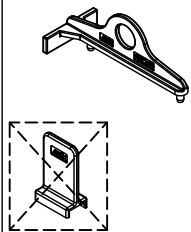

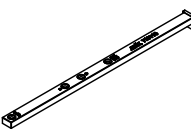
RIEPILOGO APPARECCHIATURE ANTA RIBALTA TURN & TILT HARDWARE SUMMARY

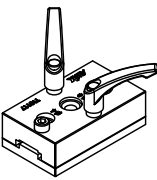
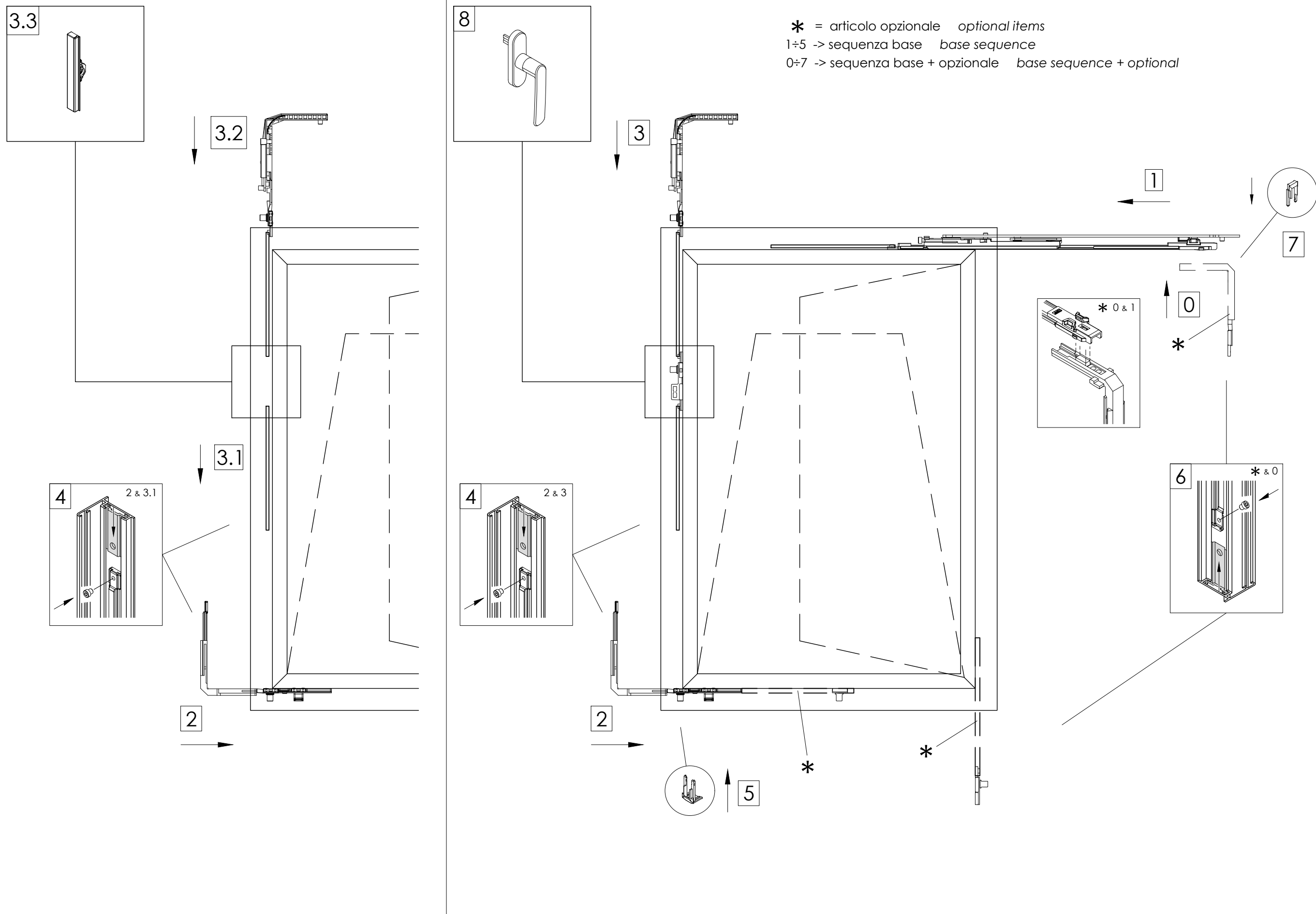
C67K	C77K	C77K-CS	C67K-M
●	●	○	○

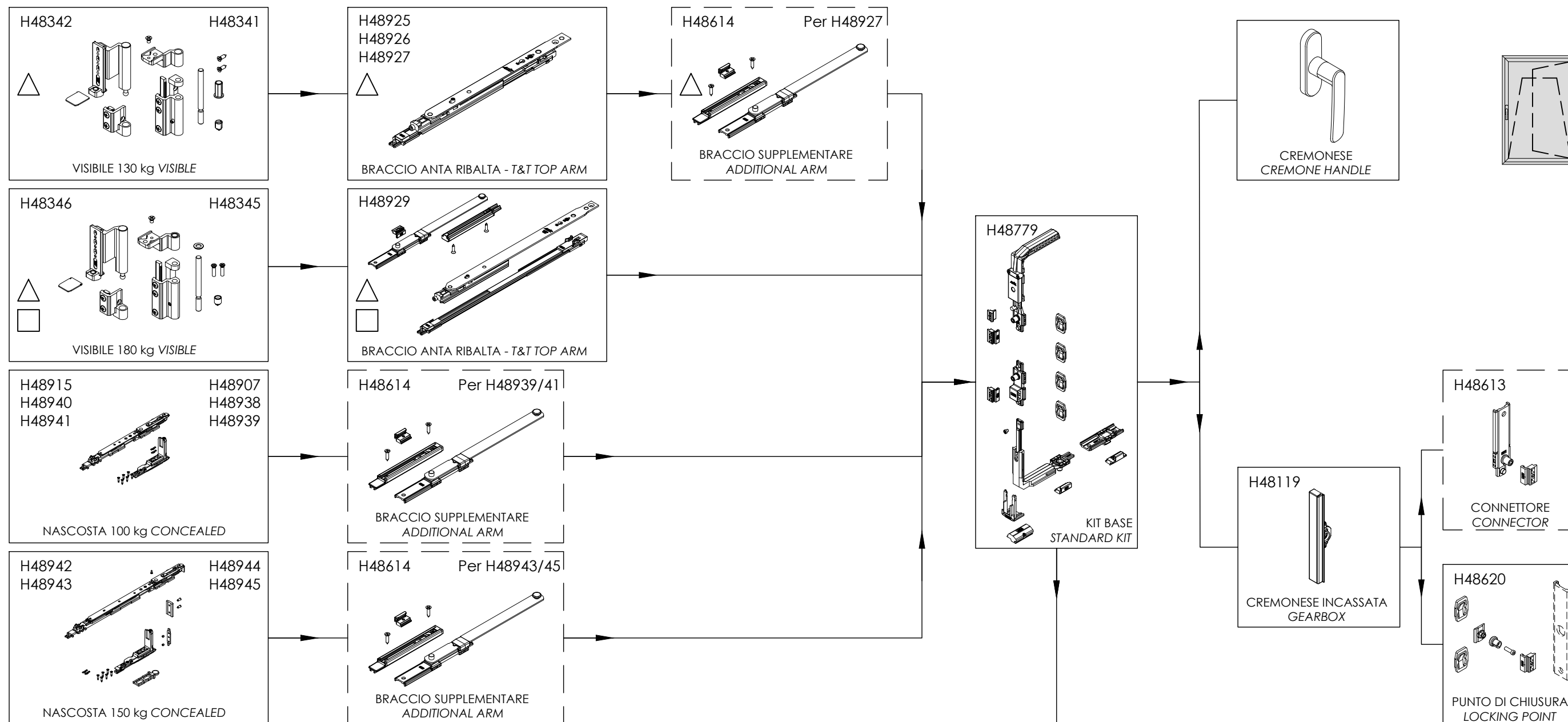

△ Non utilizzabile per C67K-M
Not usable for C67K-M

□ Non utilizzabile per C77K-CS
Not usable for C77K-CS

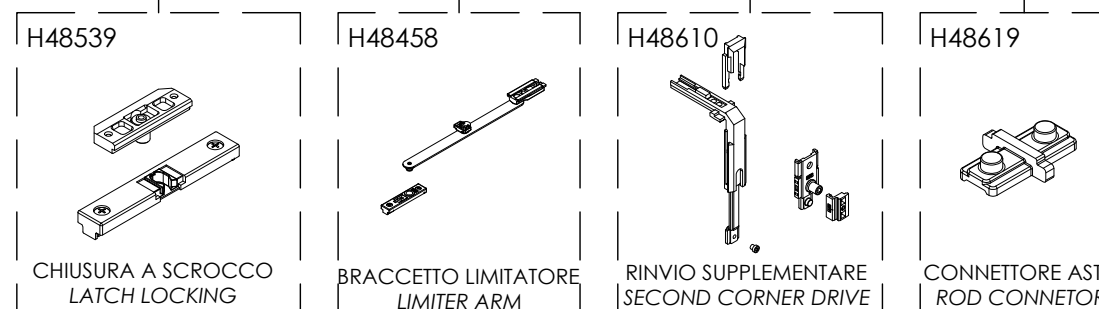

OPZIONALE
OPTIONAL

RIEPILOGO APPARECCHIATURE ANTA TURN-ONLY HARDWARE SUMMARY

C67K	C77K	C77K-CS	C67K-M
●	●	○	○

C67K	C77K	C77K-CS	C67K-M
●	●	○	○

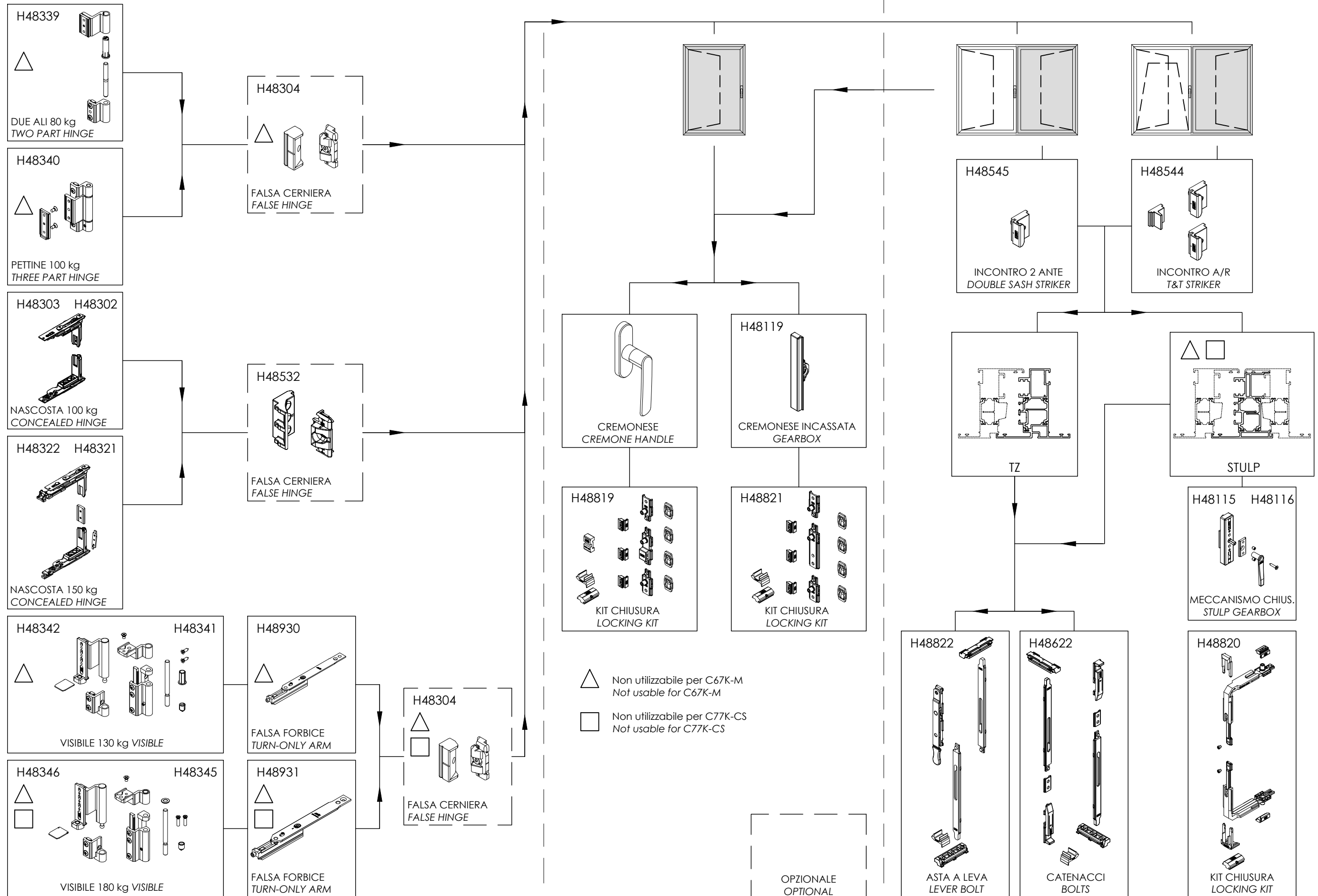

RIEPILOGO APPARECCHIATURE ANTA RIBALTA
TURN & TILT HARDWARE SUMMARY

C45K-NI	C55K-NI
●	●

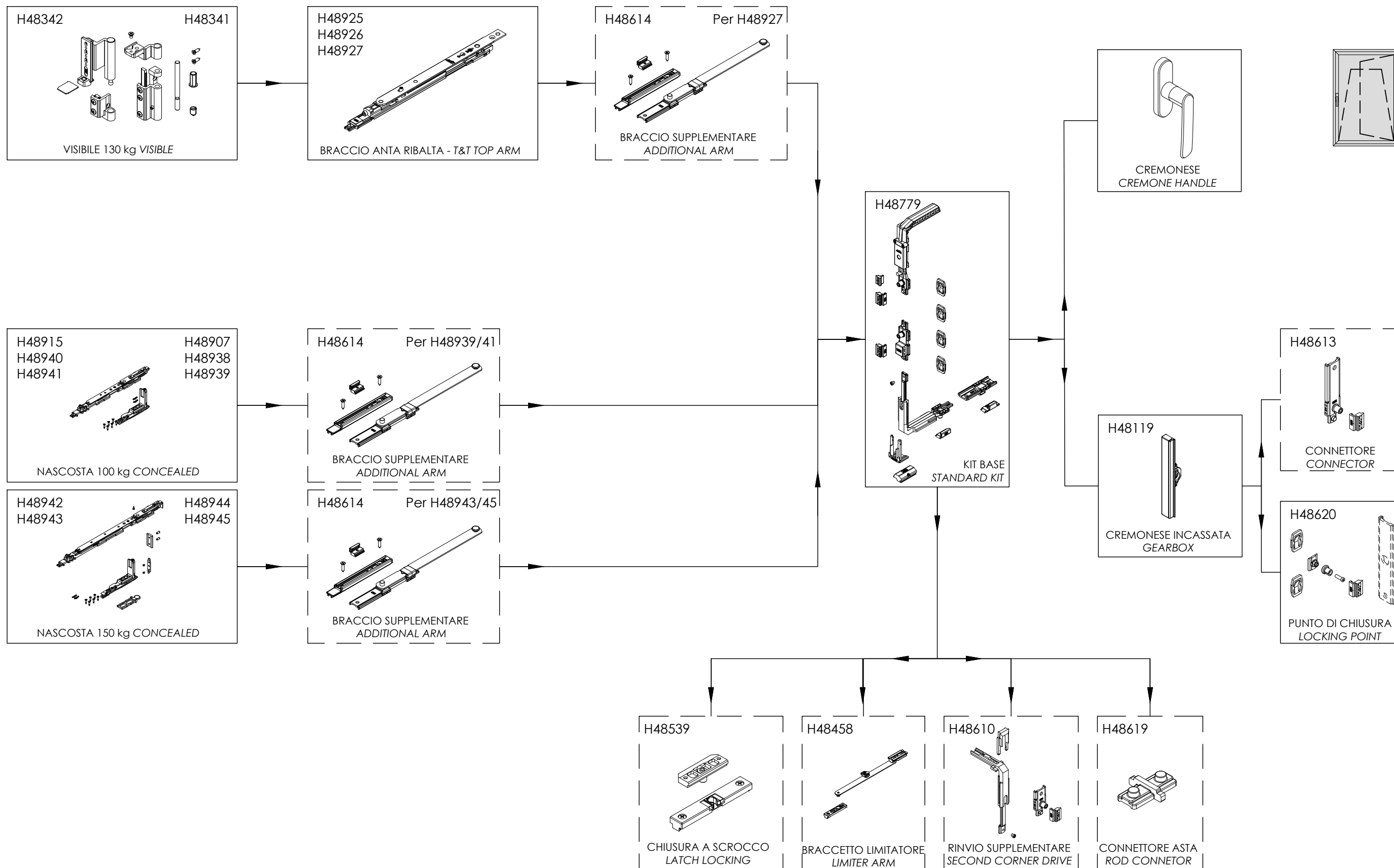

RIEPILOGO APPARECCHIATURE ANTA
TURN-ONLY HARDWARE SUMMARY

C45K-NI C55K-NI

C45K-NI C55K-NI

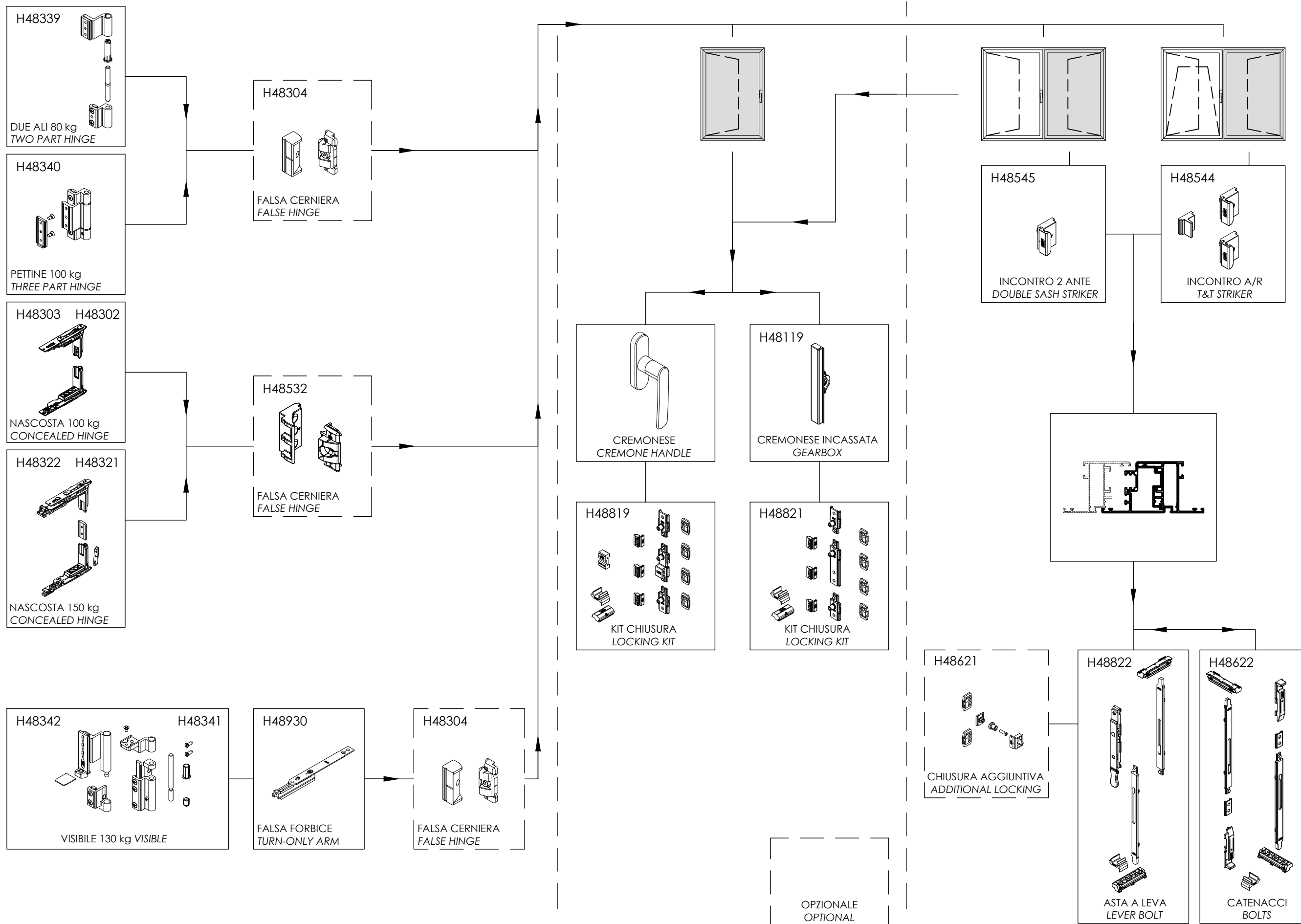

RIEPILOGO APPARECCHIATURE ANTA - aperture esterna
 TURN-ONLY HARDWARE SUMMARY - external opening

C45K-NI	C55K-NI
●	

C45K-NI	C55K-NI
●	

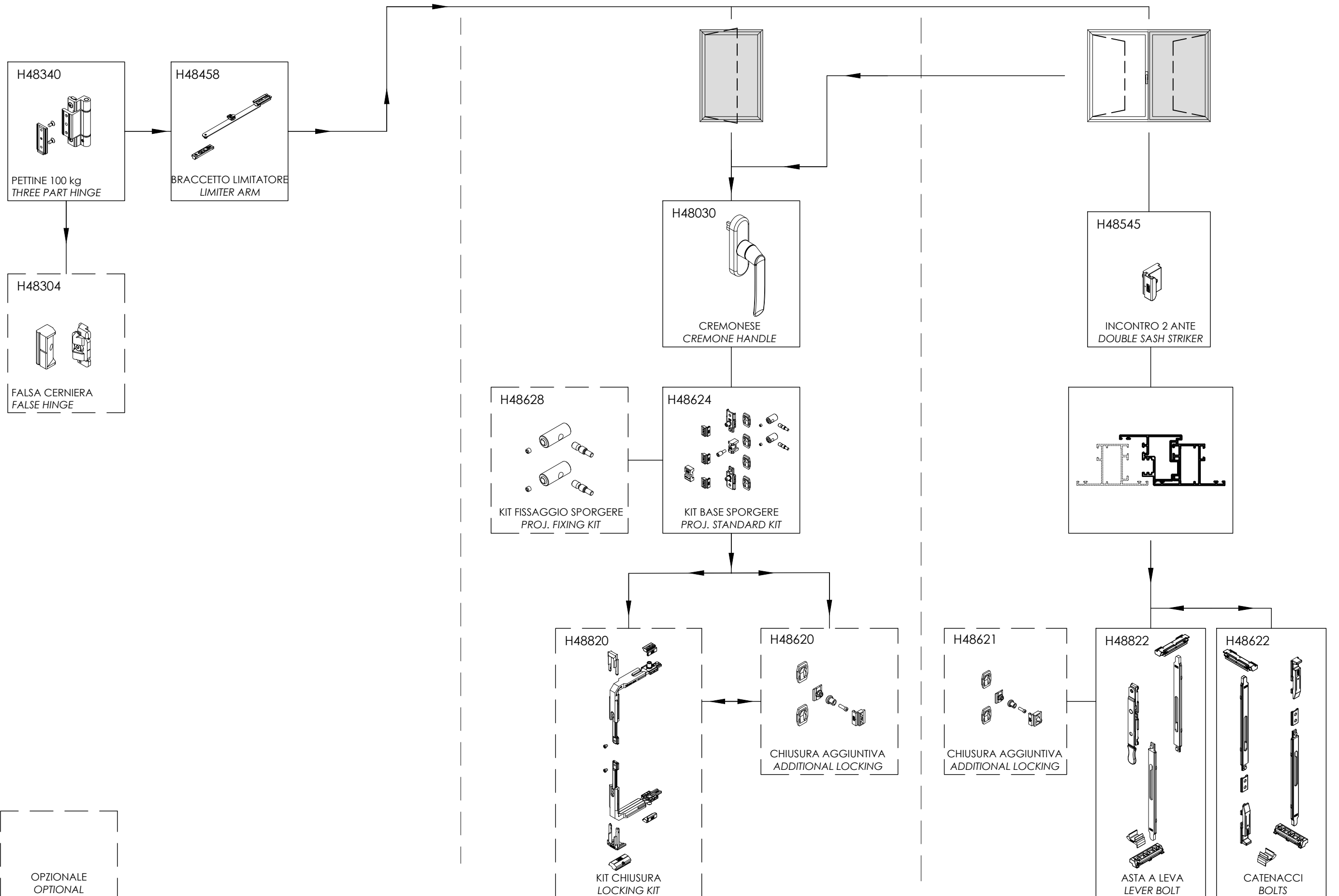

MONTAGGIO CERNIERE ANTA RIBALTA 130 kg - LATO STIPITE
130 kg TURN & TILT HINGE ASSEMBLING - FRAME SIDE

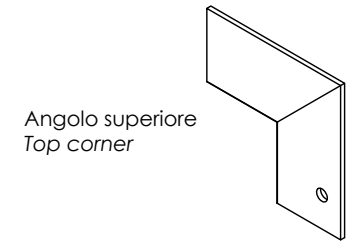
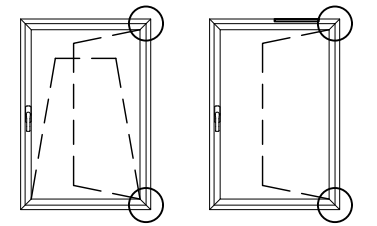
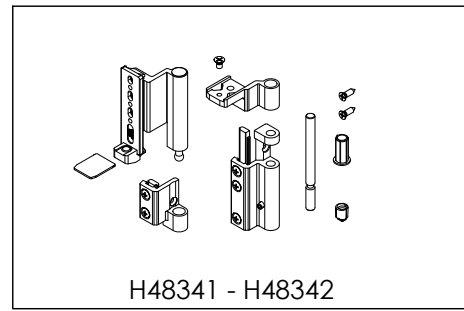
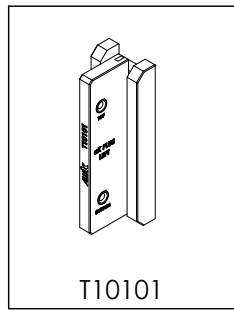

Angolo inferiore
Bottom corner

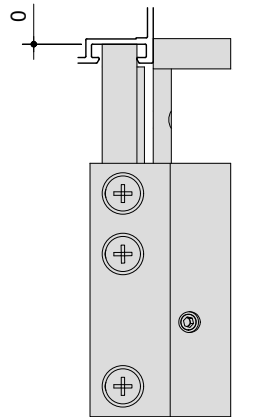
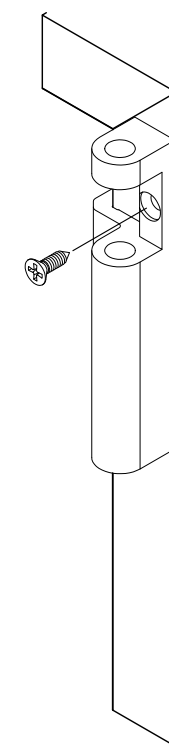
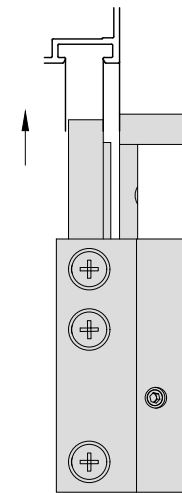
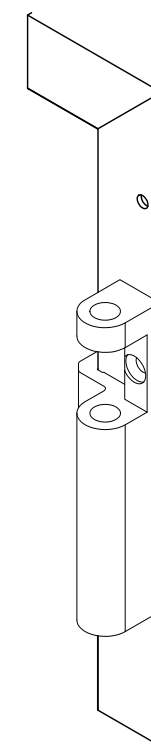
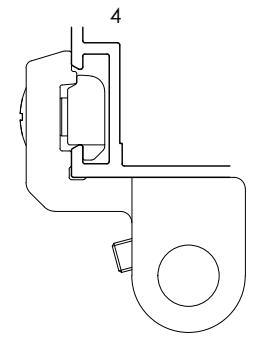
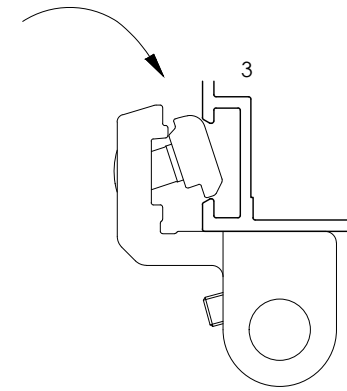
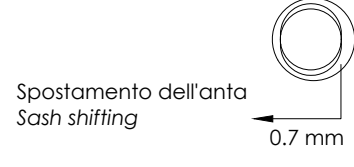
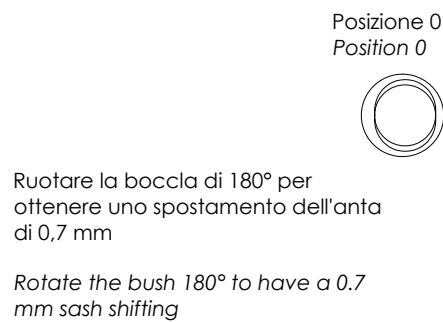
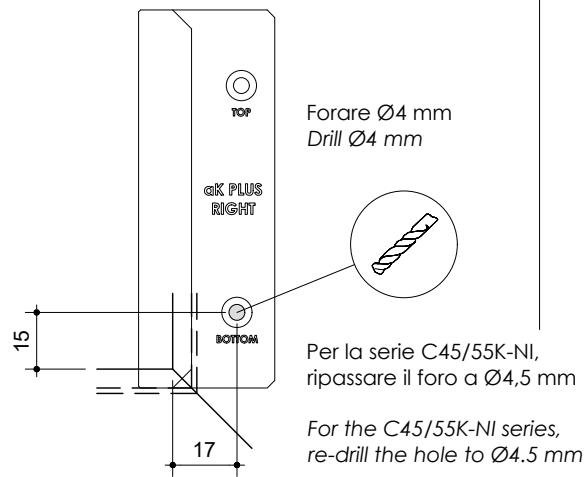
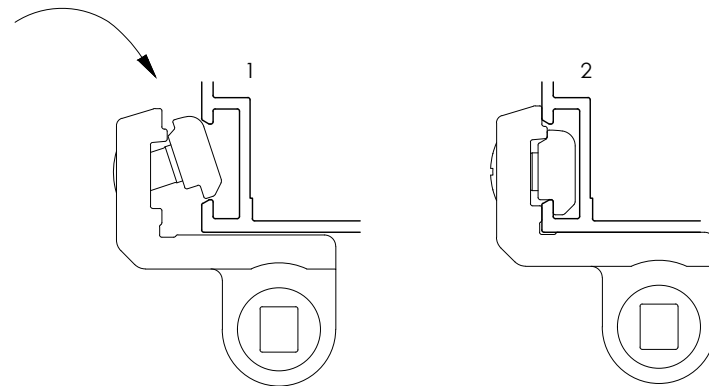
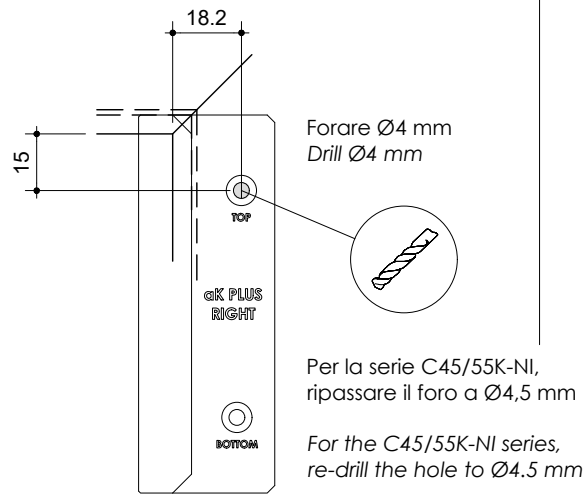
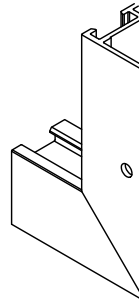

In appoggio in fondo cava
In contact with groove base

MONTAGGIO CERNIERE ANTA RIBALTA (HD) 180 kg - LATO STIPITE
180 kg (HD) TURN & TILT HINGE ASSEMBLING - FRAME SIDE

⊕ Disponibilità futura
 Future availability

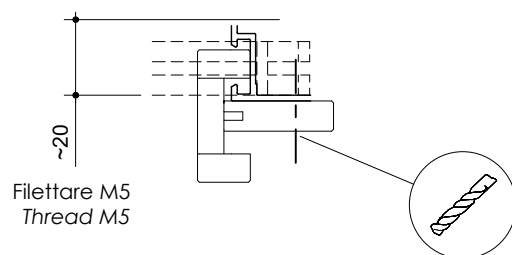
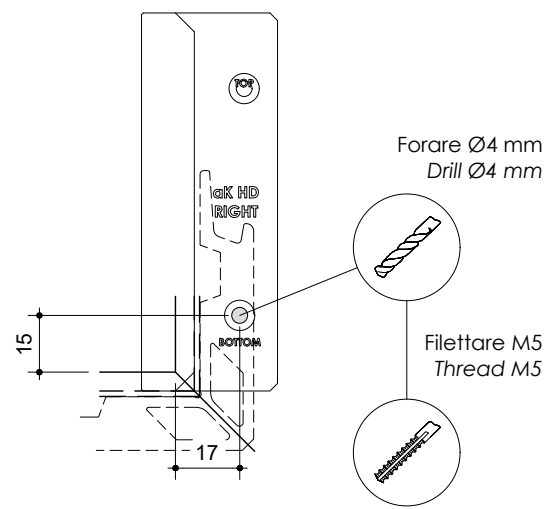
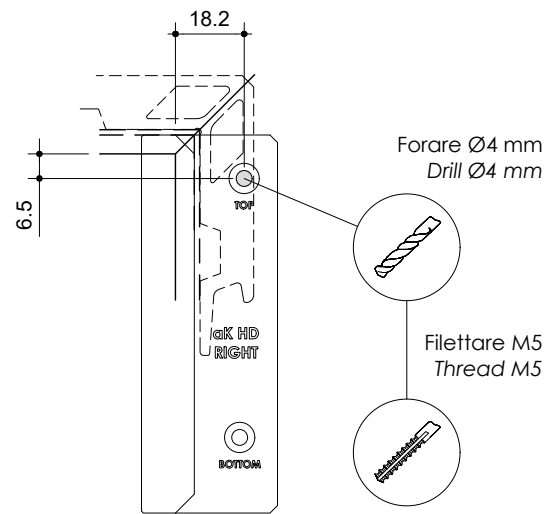
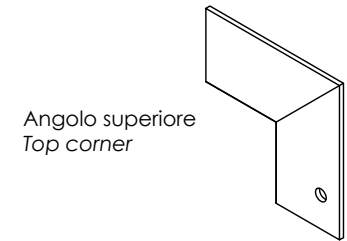
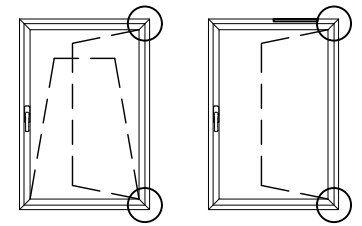
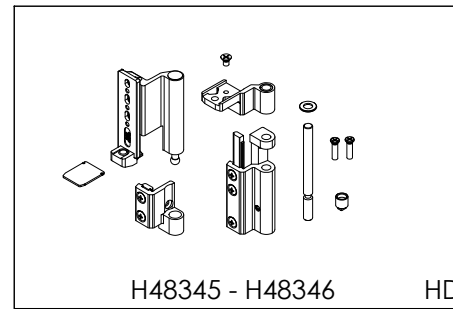
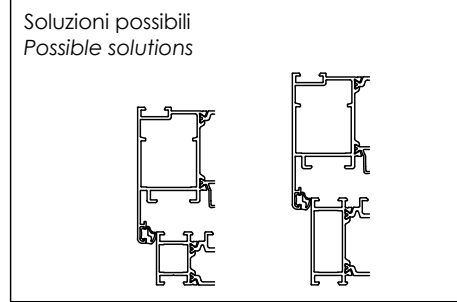
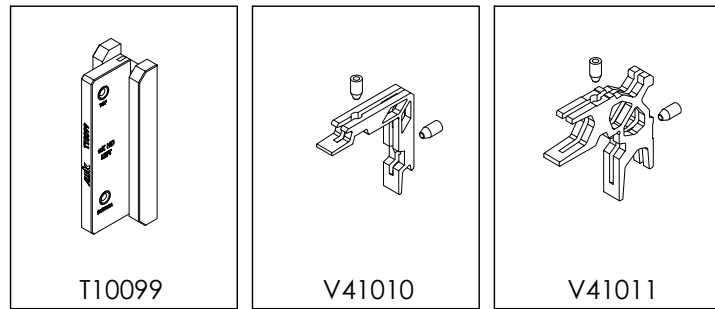

Angolo inferiore
 Bottom corner

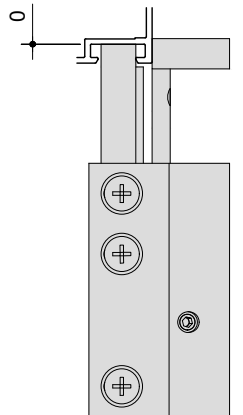
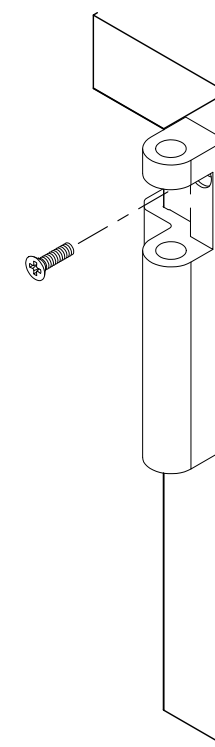
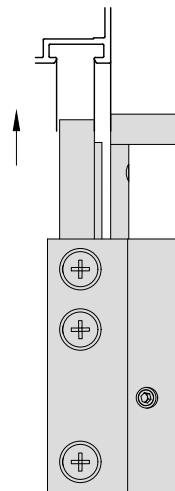
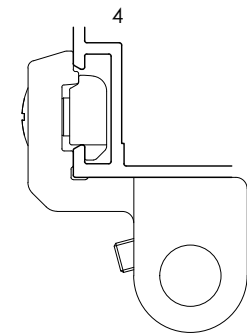
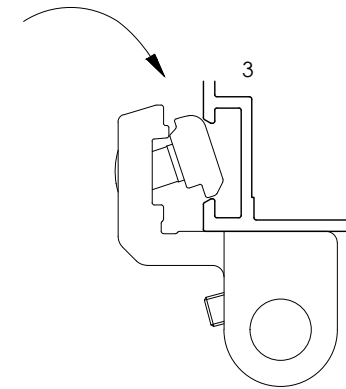
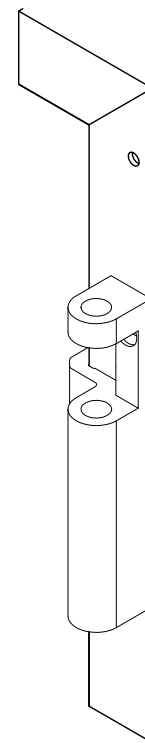
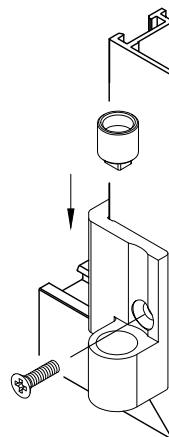
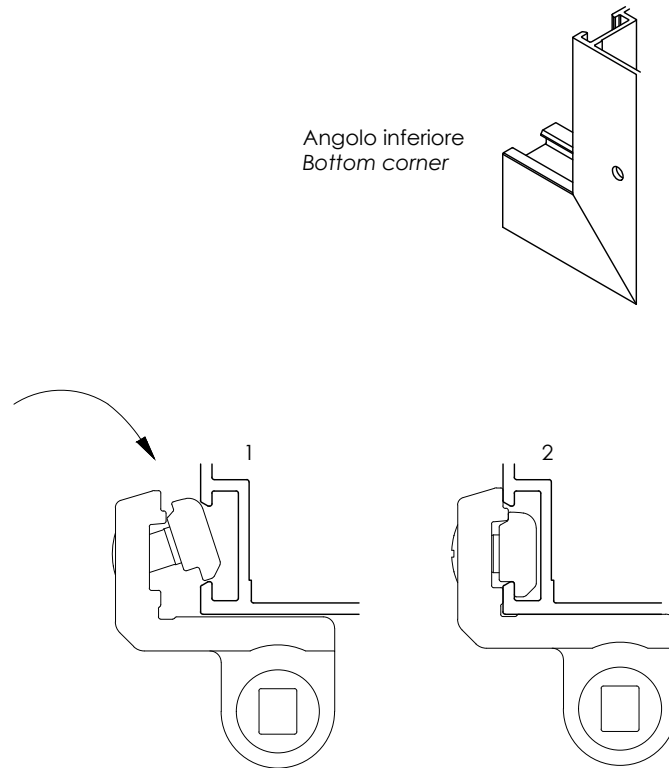

In appoggio in fondo cava
 In contact with groove base

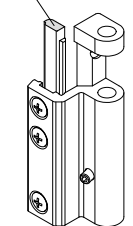

MONTAGGIO CERNIERE ANTA RIBALTA 130 e 180 kg - LATO BATTENTE

130 & 180 kg TURN & TILT HINGE ASSEMBLING - SASH SIDE

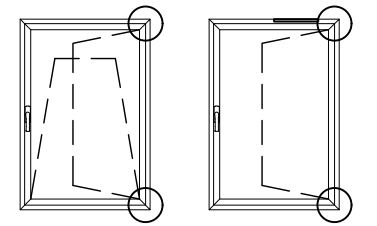

Soluzioni possibili per 180 kg
Possible solutions for 180 kg

⊛ Disponibilità futura
Future availability

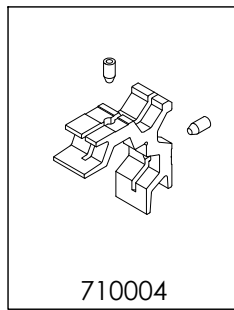
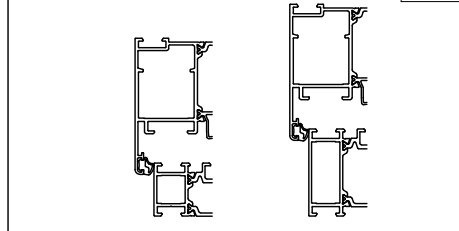

Montaggio piatto di rinforzo cerniera
Hinge reinforcement plate assembling

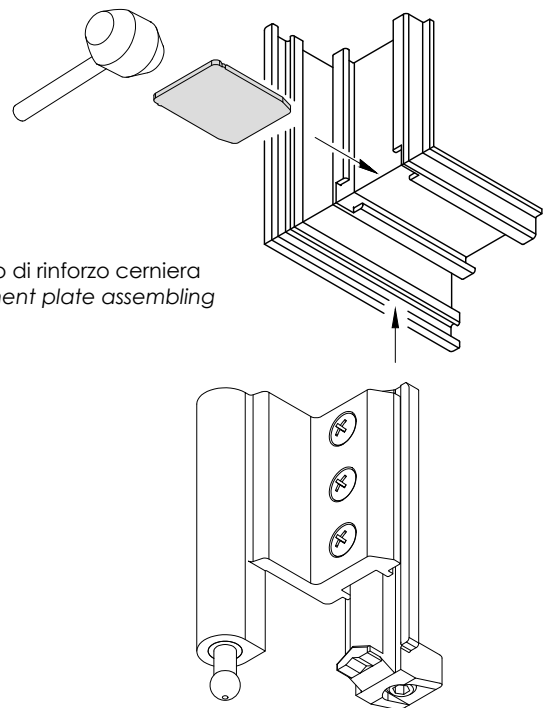

Montaggio della semicerniera in cava
Half-hinge groove assembling

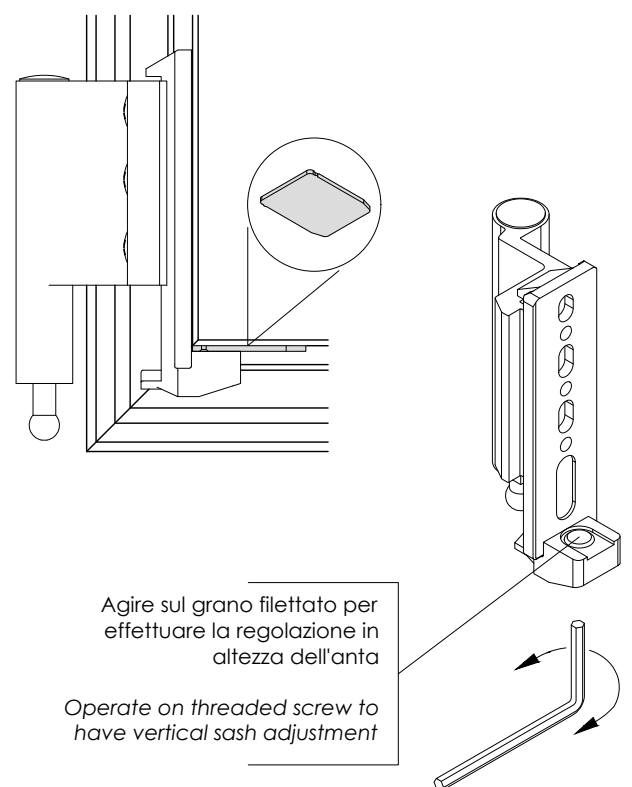
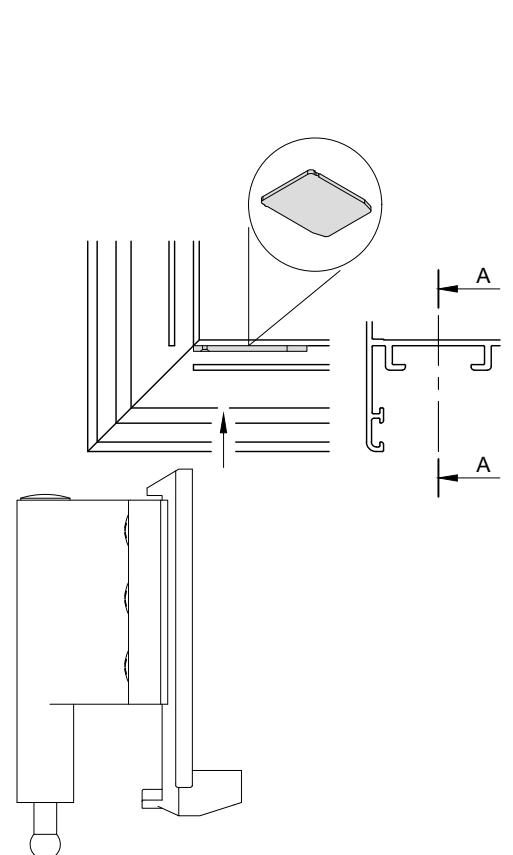

130 kg

180 kg

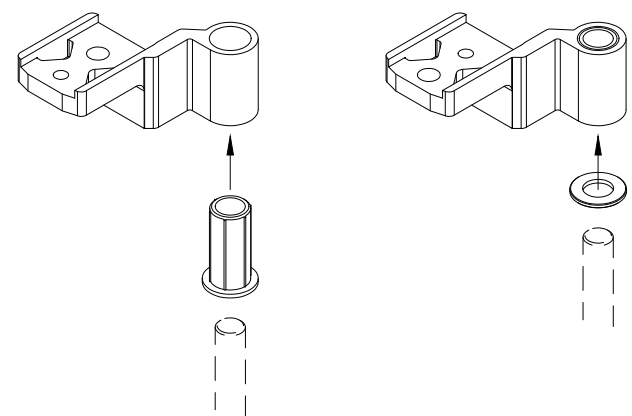

La semicerniera superiore deve essere fissata al braccio
ESCLUSIVAMENTE con la vite speciale con bloccafiletto

Upper hinge must be MANDATORY fixed on top arm by special screw with thread stopper

H48925
H48926
H48927

H48929

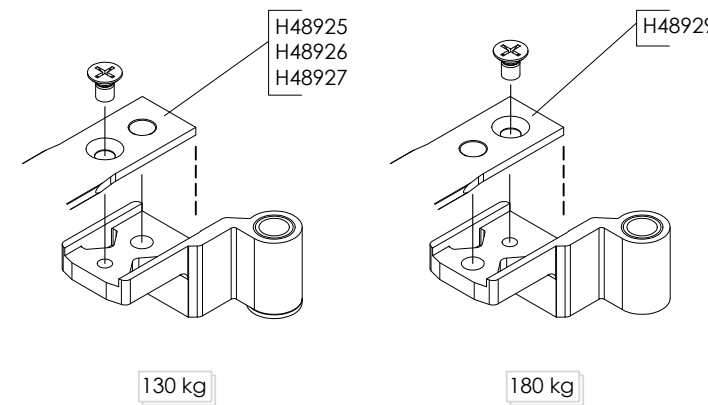

Agire sul grano filettato per bloccare il perno
Operate on threaded screw to lock the pin

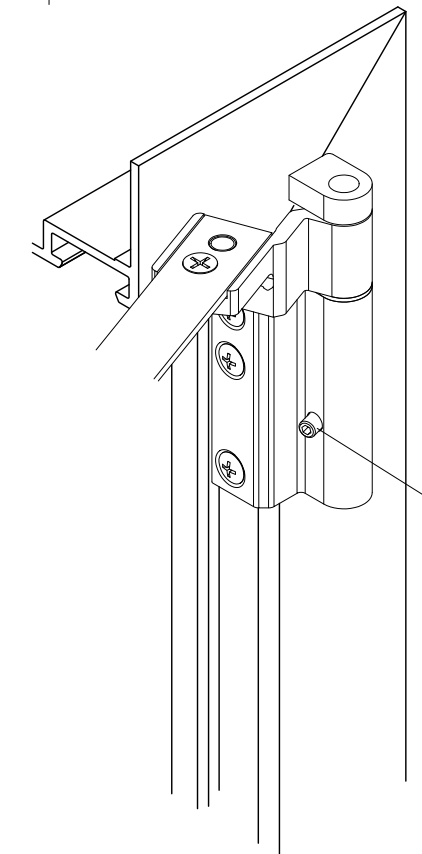

Per la variante 180 kg il vetro deve essere sigillato stutturalmente
Per maggiori dettagli vedere il repertorio "Tavole di vetrage"

On 180kg option, glass shall be structurally sealed
More details on "Glazing Detail" chapter

MONTAGGIO CERNIERE NASCOSTE ANTA RIBALTA 100 kg
100 kg TURN & TILT CONCEALED HINGE ASSEMBLING

LB=430÷479
 HB_{min}=600
 A=98

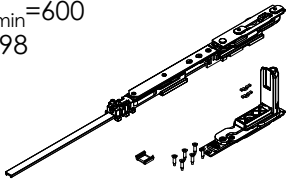

H48907 - H48915

T0 LB=480÷609
 HB_{min}=600
 A=98

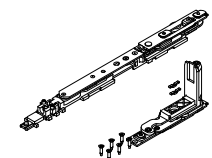

H48938 - H48940

T1 LB=610÷1059
 HB_{min}=900
 A=148÷178

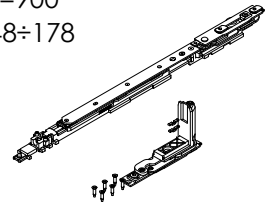

H48939 - H48941

T2 LB=610÷1059
 HB_{min}=900
 A=148÷178

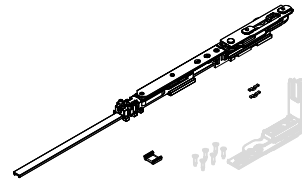

H48907 - H48915

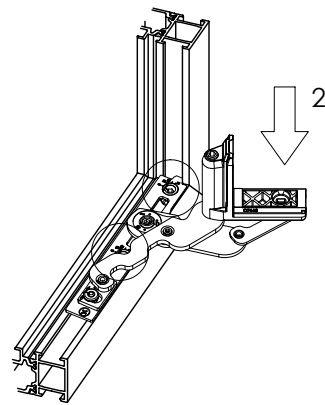
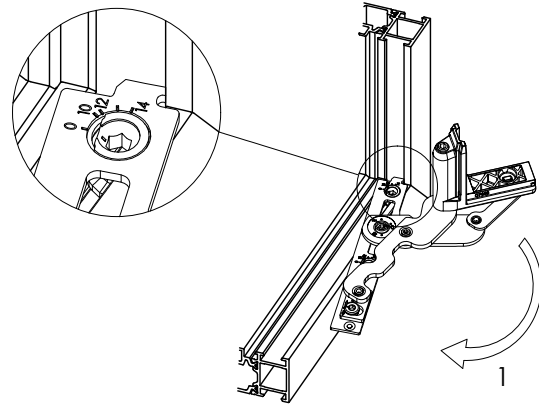
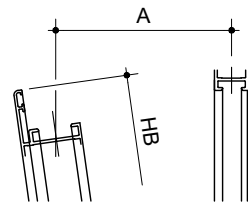

BLOCCAGGIO DELLE CAMMES
 CAMMES LOCK

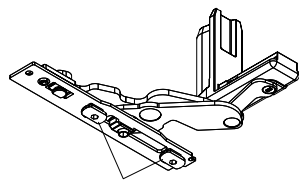
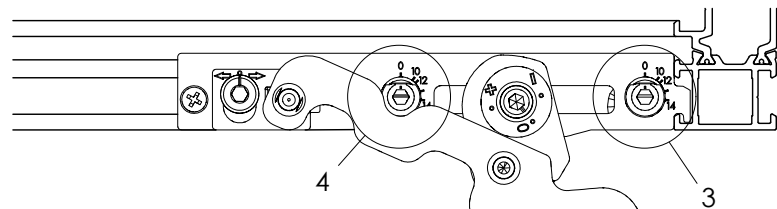

Cammes di fissaggio
 Fixing cammes

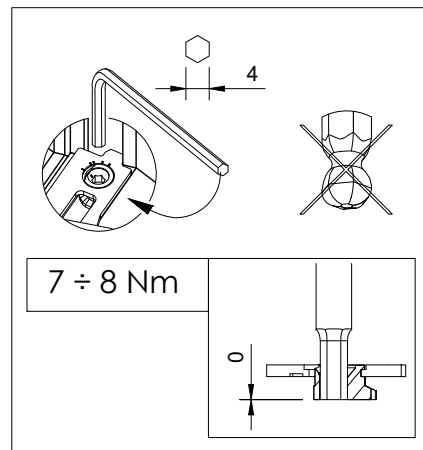
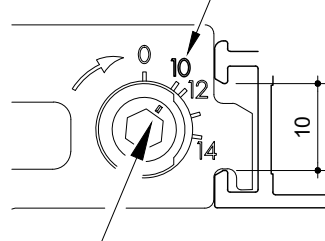

FISSAGGIO DELLE VITI
 SCREW FIXING

Pre-forare Ø2.7 mm
 Pre-drill Ø2.7 mm

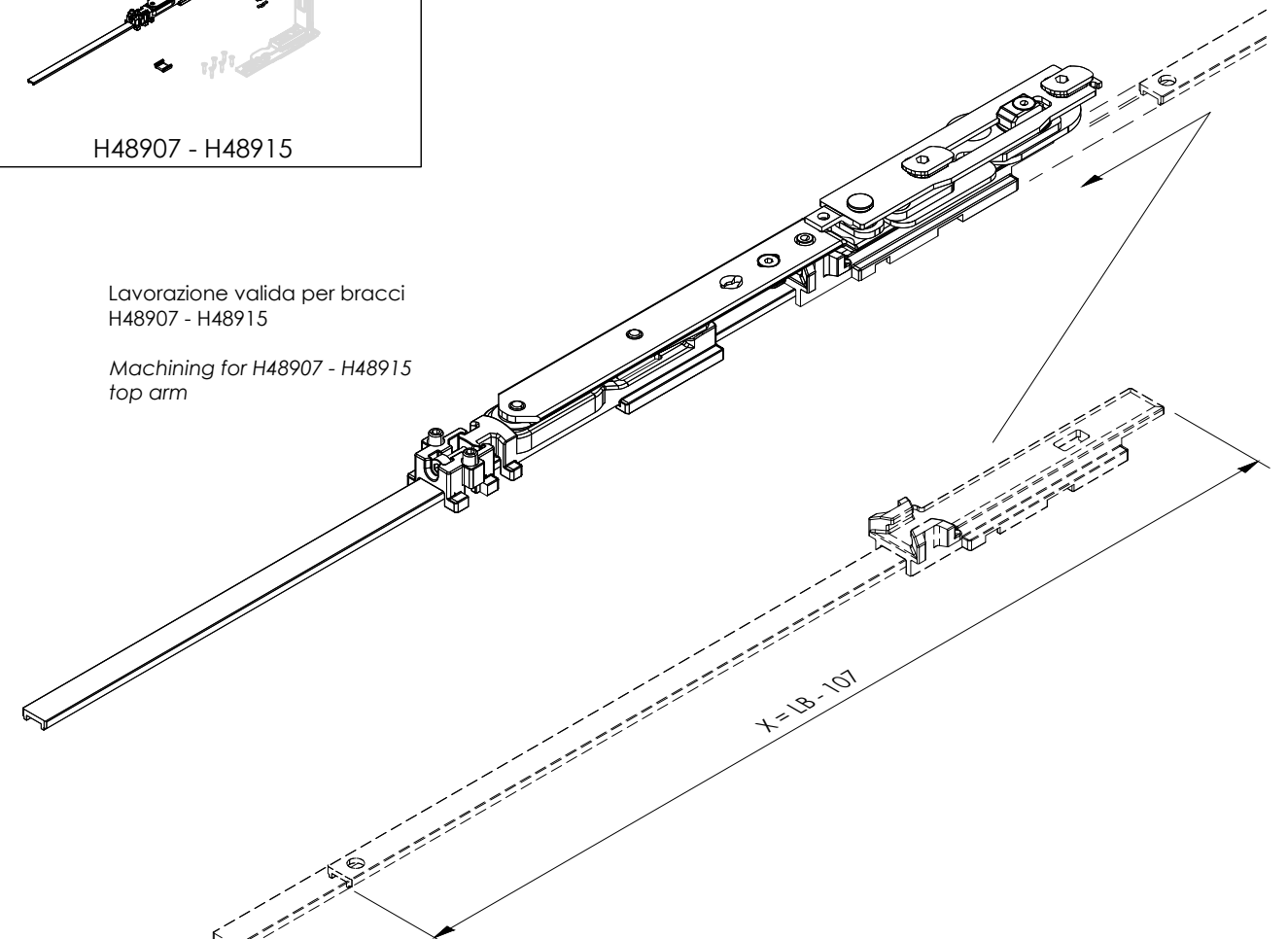
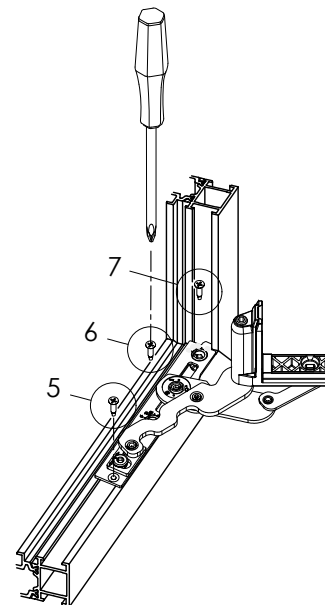
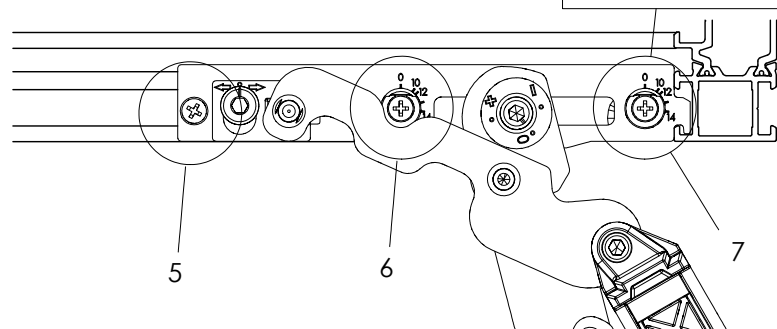

Posizionare la clip in prossimità
 del rinvio d'angolo

Position the clip close to the
 corner trasmission

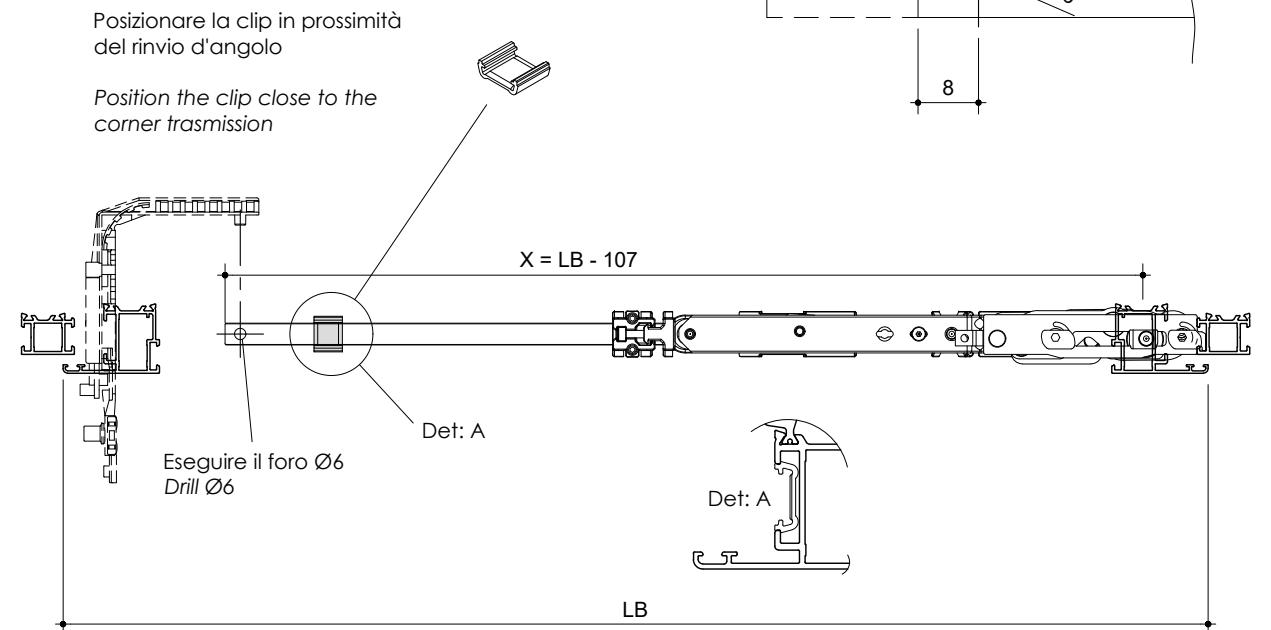
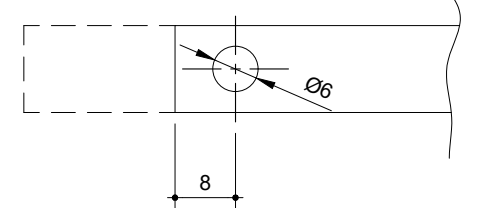

MONTAGGIO CERNIERE NASCOSTE ANTA RIBALTA 100 kg 100 kg TURN & TILT CONCEALED HINGE ASSEMBLING

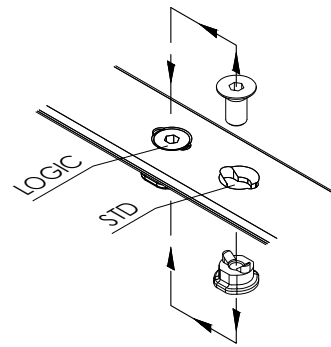
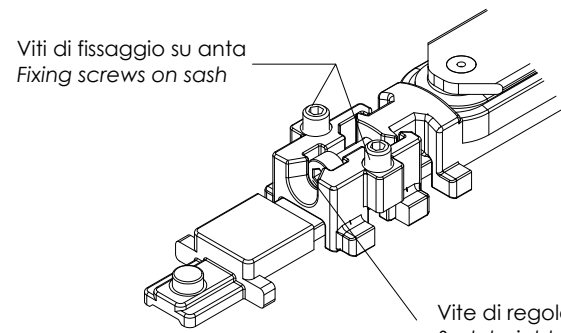
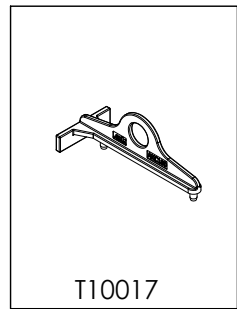
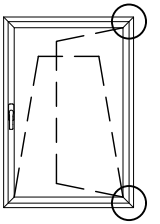

Per modificare l'apertura da anta/ribalta a ribalta/anta, spostare il nottolino dal foro STD a LOGIC. Serrare a fondo la vite (coppia 2 Nm) trattenendo il nottolino con una pinza gommata. Lubrificare la superficie esterna del nottolino e la sua sede in zama.

To change the opening from turn & tilt to tilt before turn, move the pawl from the STD hole to LOGIC. Fully tighten the screw (torque 2 Nm) holding the pawl with a rubberized pliers. Lubricate the external surface of the pawl and its striking point.

Braccio Top arm	X [mm]	L3
H48915/H48907	294	-
H48938/H48940	294	LB - 422
H48939/H48941	417	LB - 545

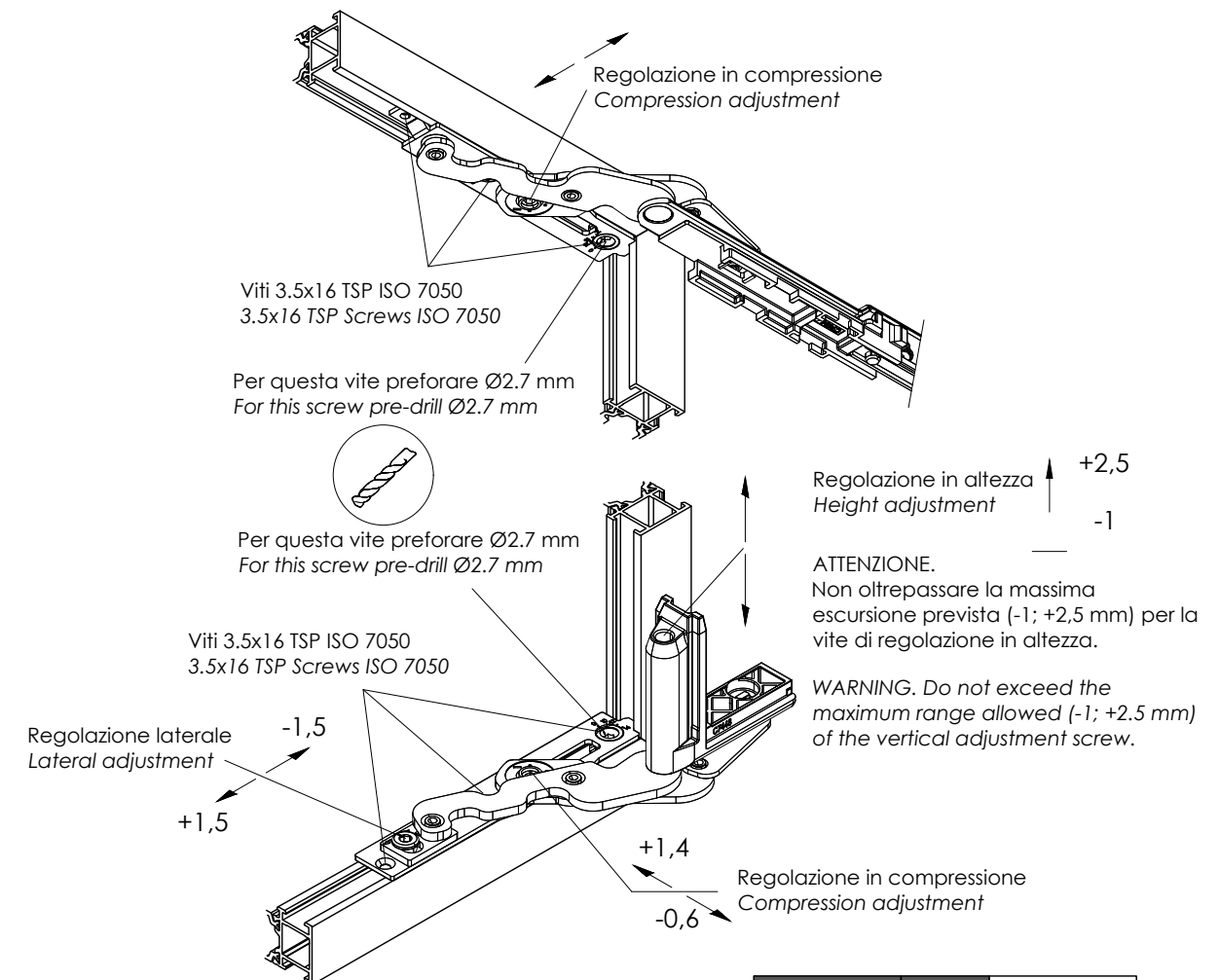
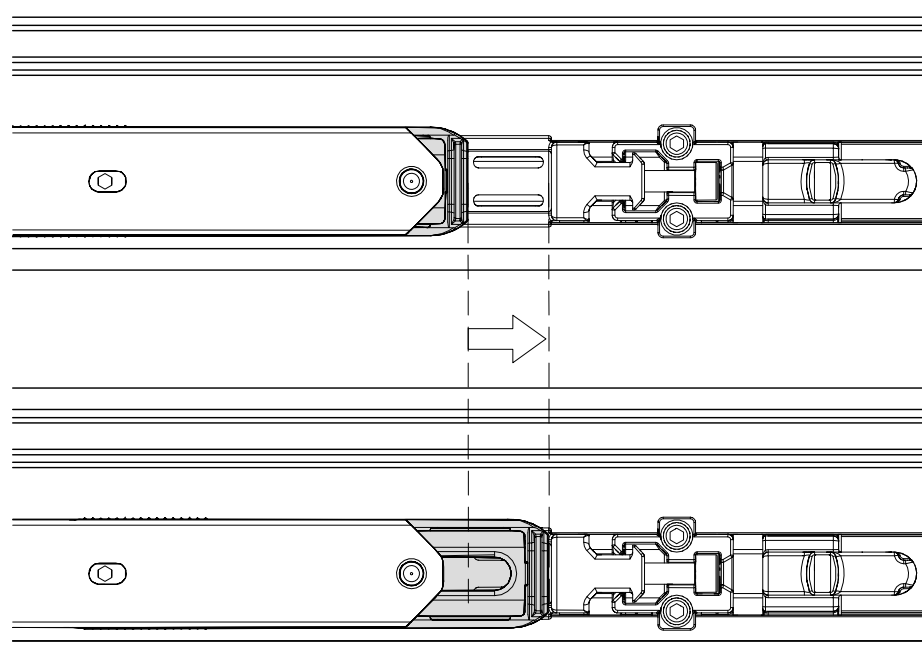
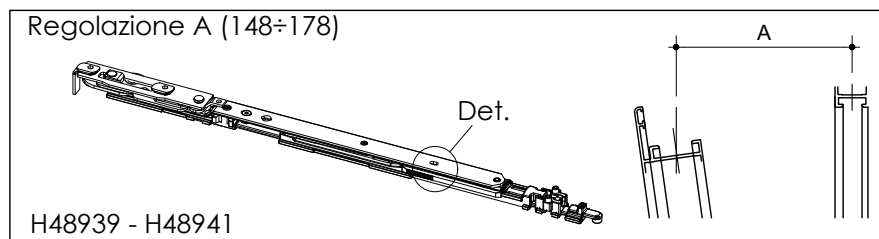
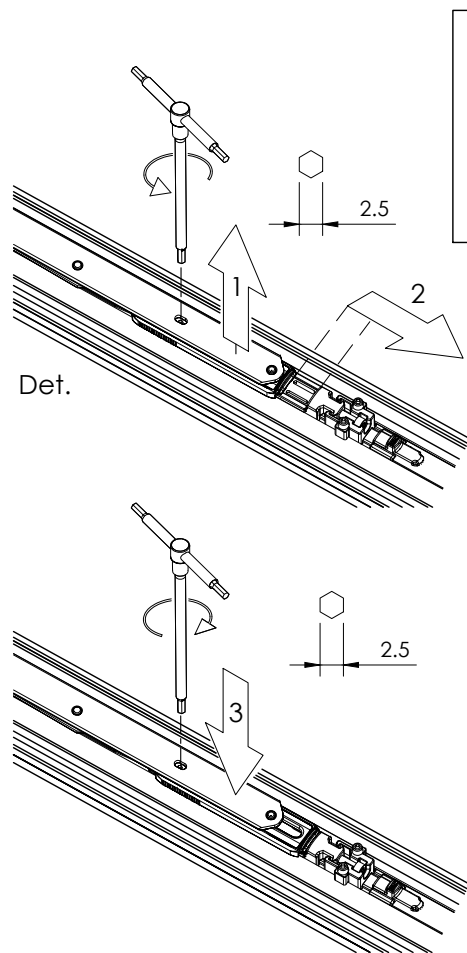
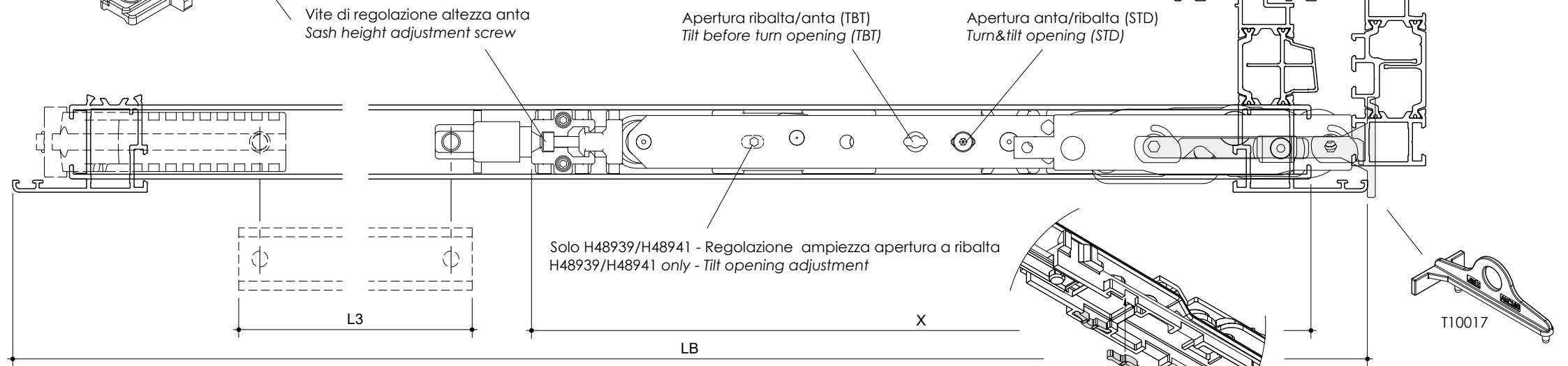

MONTAGGIO CERNIERE NASCOSTE ANTA RIBALTA 150 kg
150 kg TURN & TILT CONCEALED HINGE ASSEMBLING

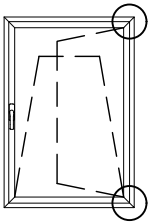

LB=480÷609
 HB_{min}=600
 A=98

H48942 - H48944

LB=610÷1059
 HB_{min}=900
 A=148÷178

H48943 - H48945

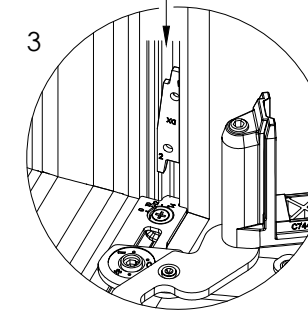
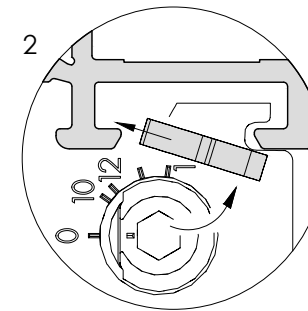
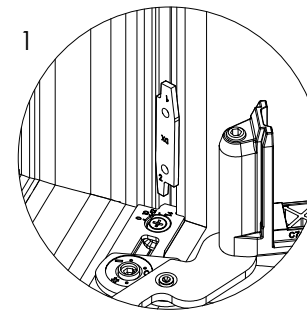
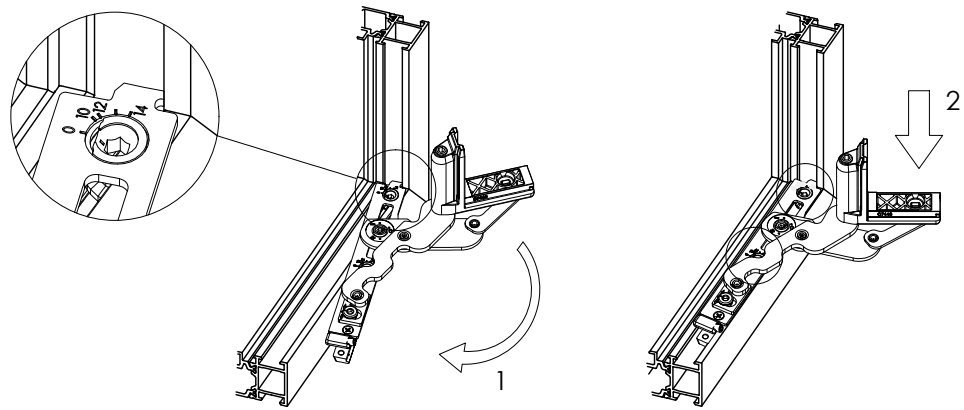
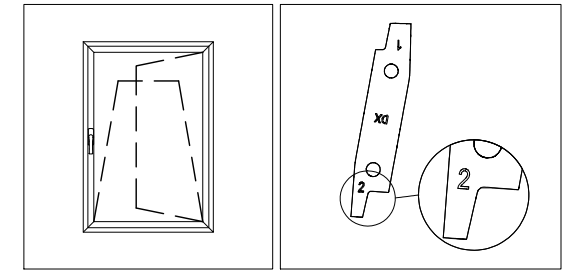
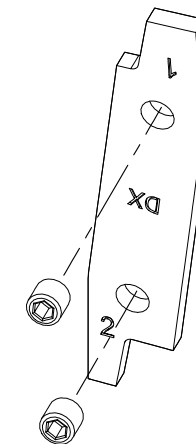
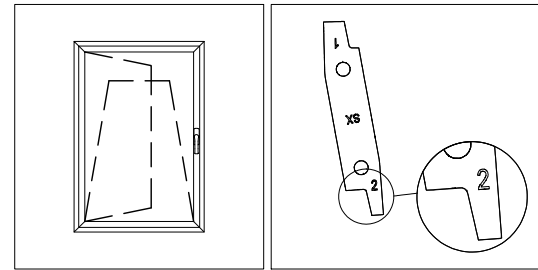
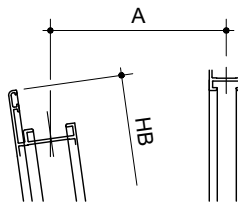

BLOCCAGGIO DELLE CAMMES
 CAMMES LOCK

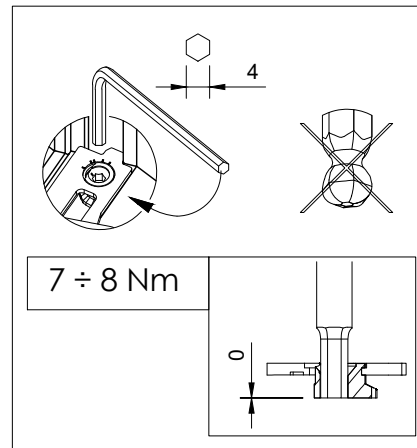
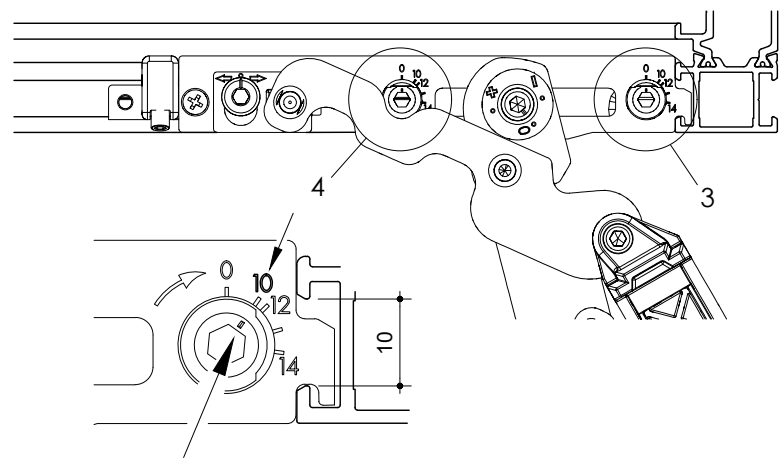

FISSAGGIO DELLE VITI
 SCREW FIXING

Pre-forare Ø2.7 mm
 Pre-drill Ø2.7 mm

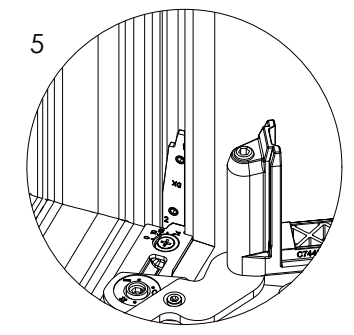
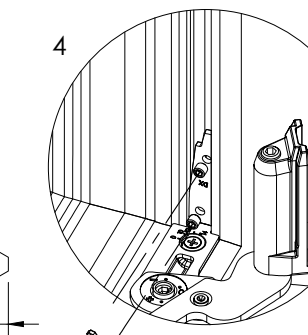
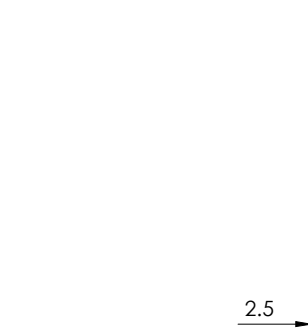
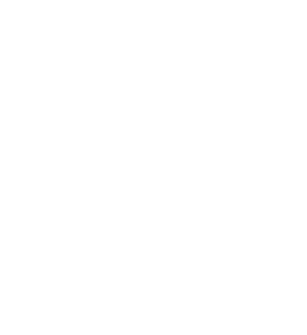
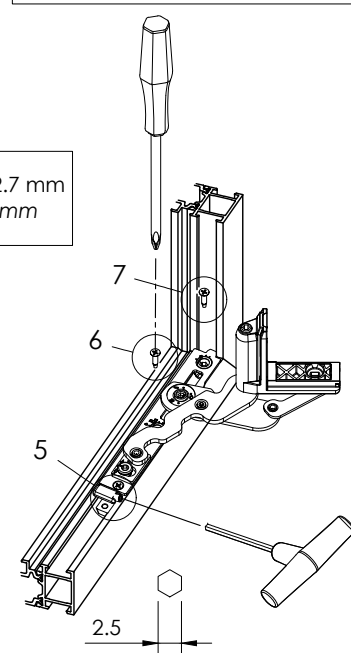
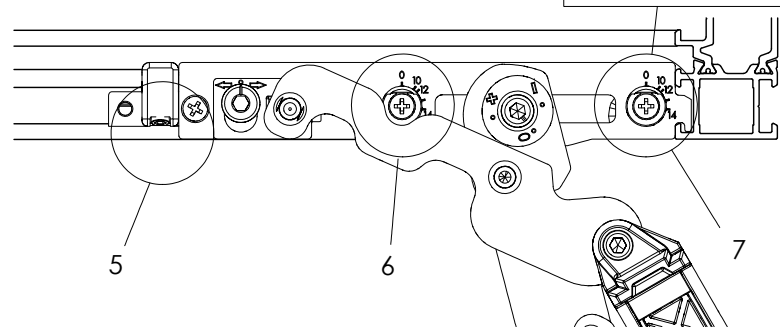

2.5

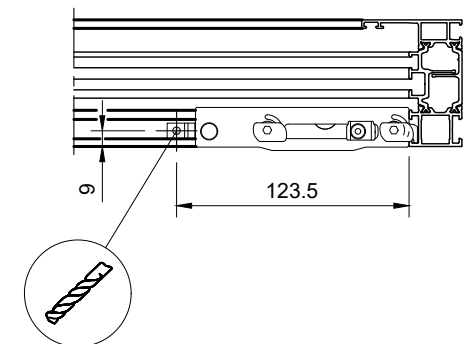
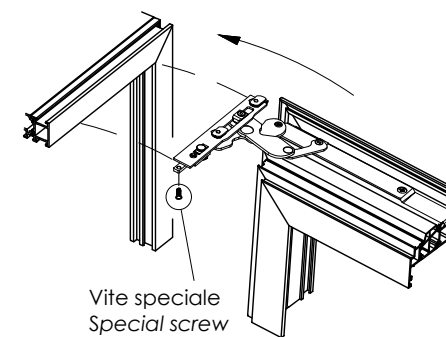
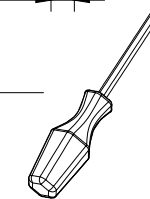

Forare Ø2.3 per il fissaggio della vite speciale con frenafilo (serraggio della vite 2 Nm)

Drill Ø2.3 for special screw with thread lock fixing (screw tightening 2 Nm)

MONTAGGIO CERNIERE NASCOSTE ANTA RIBALTA 150 kg 150 kg TURN & TILT CONCEALED HINGE ASSEMBLING

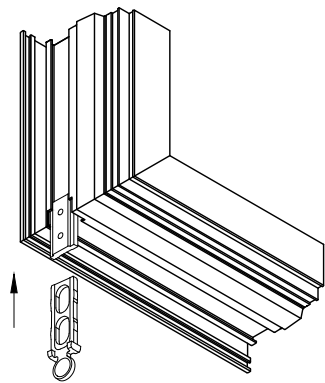
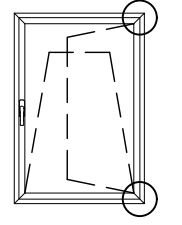

Utilizzare la dima per il posizionamento delle cerniere
Use the template for hinge positioning

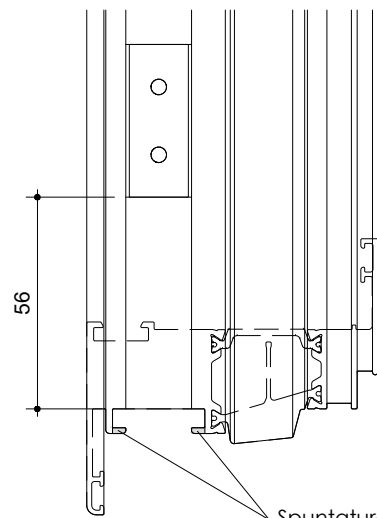

Spuntatura alette
Sash end groove machining

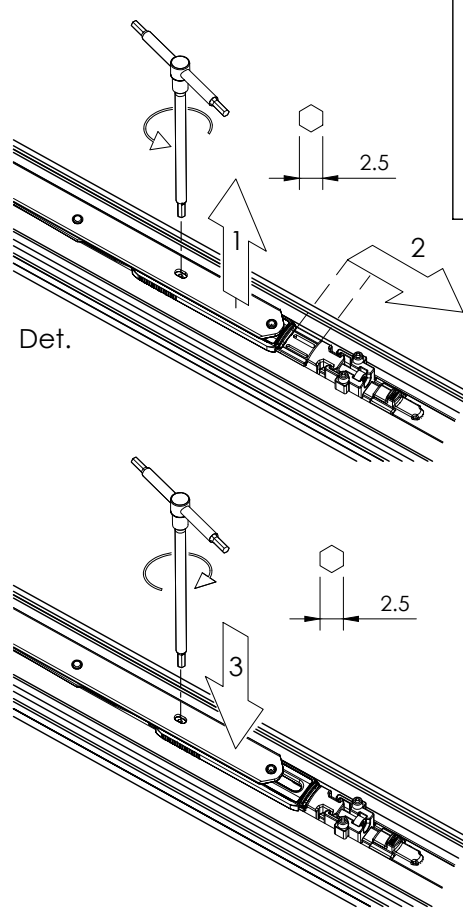
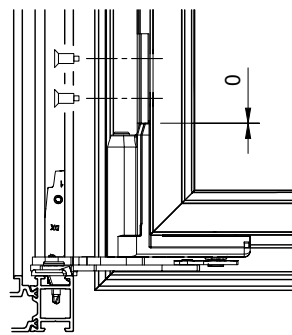

Regolazione A (148÷178)

H48943 - H48945

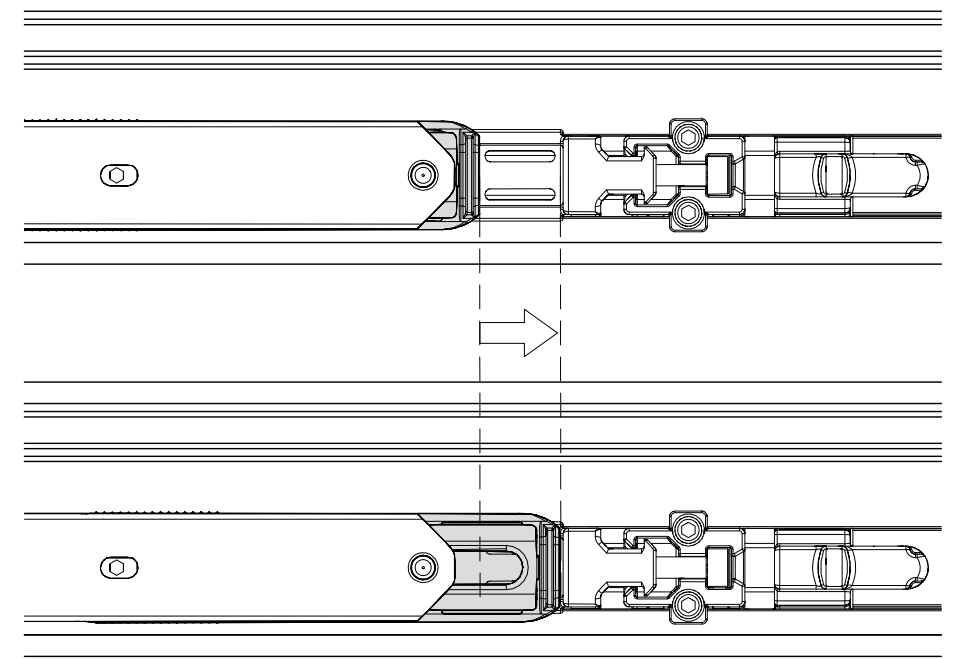
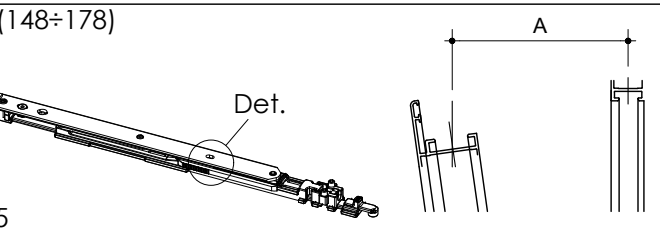

Viti di fissaggio su anta
Fixing screws on sash

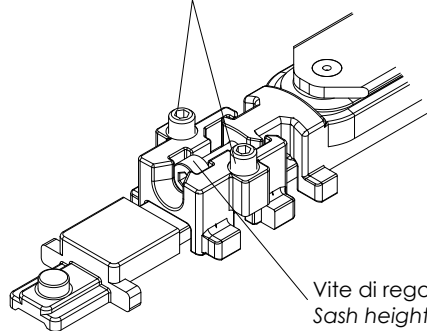

Vite di regolazione altezza anta
Sash height adjustment screw

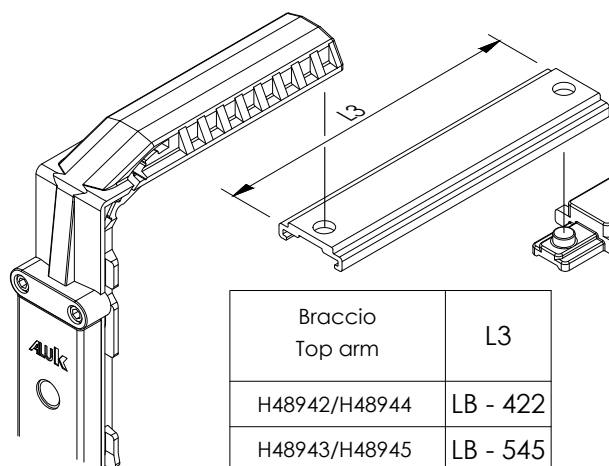

Braccio Top arm	L3
H48942/H48944	LB - 422
H48943/H48945	LB - 545

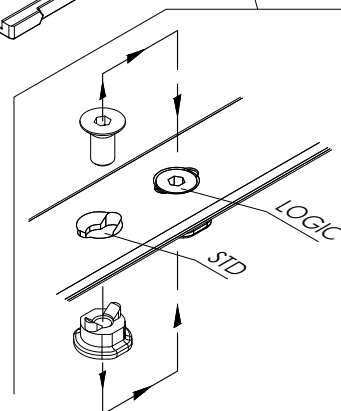

Per modificare l'apertura da anta/ribalta a ribalta/anta, spostare il nottolino dal foro STD a LOGIC.
Serrare a fondo la vite (coppia 2 Nm) trattenendo il nottolino con una pinza gommata. Lubrificare la superficie esterna del nottolino e la sua sede in zama.
To change the opening from turn & tilt before turn, move the pawl from the STD hole to LOGIC.
Fully tighten the screw (torque 2 Nm) holding the pawl with rubberized pliers. Lubricate the external surface of the pawl and its striking point.

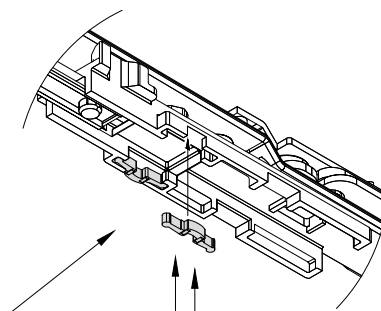

Regolazione in compressione
Compression adjustment

Regolazione laterale
Lateral adjustment

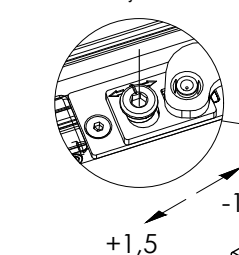

Regolazione in altezza
Height adjustment

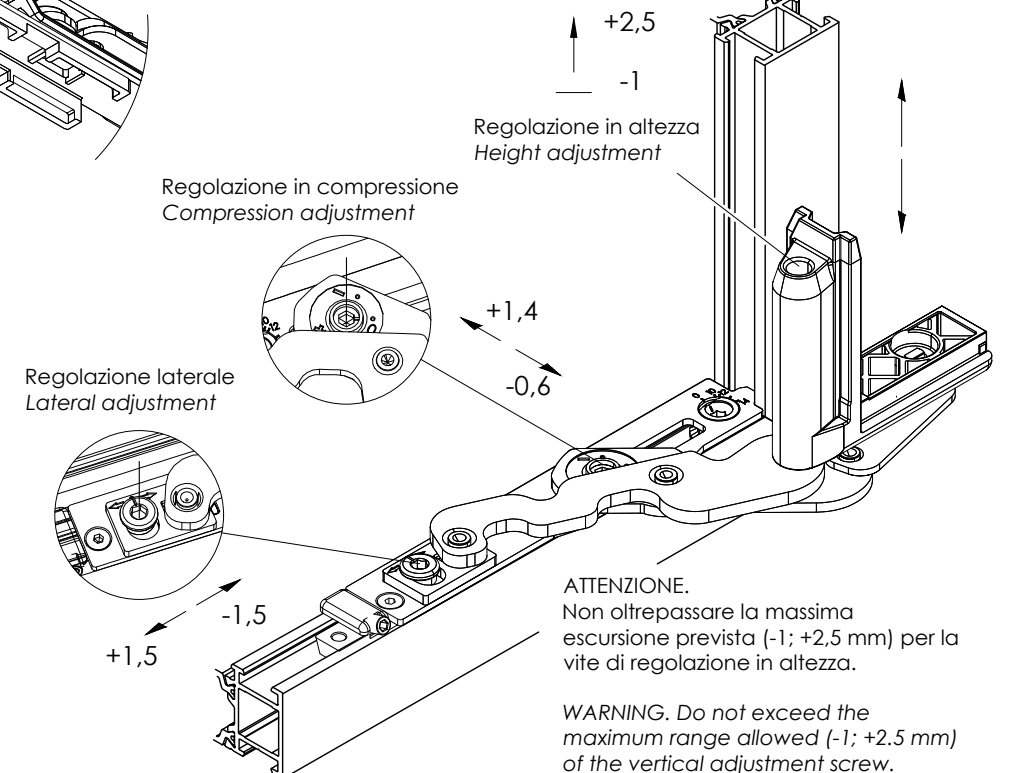

ATTENZIONE.
Non oltrepassare la massima escursione prevista (-1; +2,5 mm) per la vite di regolazione in altezza.

WARNING. Do not exceed the maximum range allowed (-1; +2.5 mm) of the vertical adjustment screw.

▶ MONTAGGIO BRACCIO ANTARIBALTA
TILT & TURN ARM ASSEMBLING

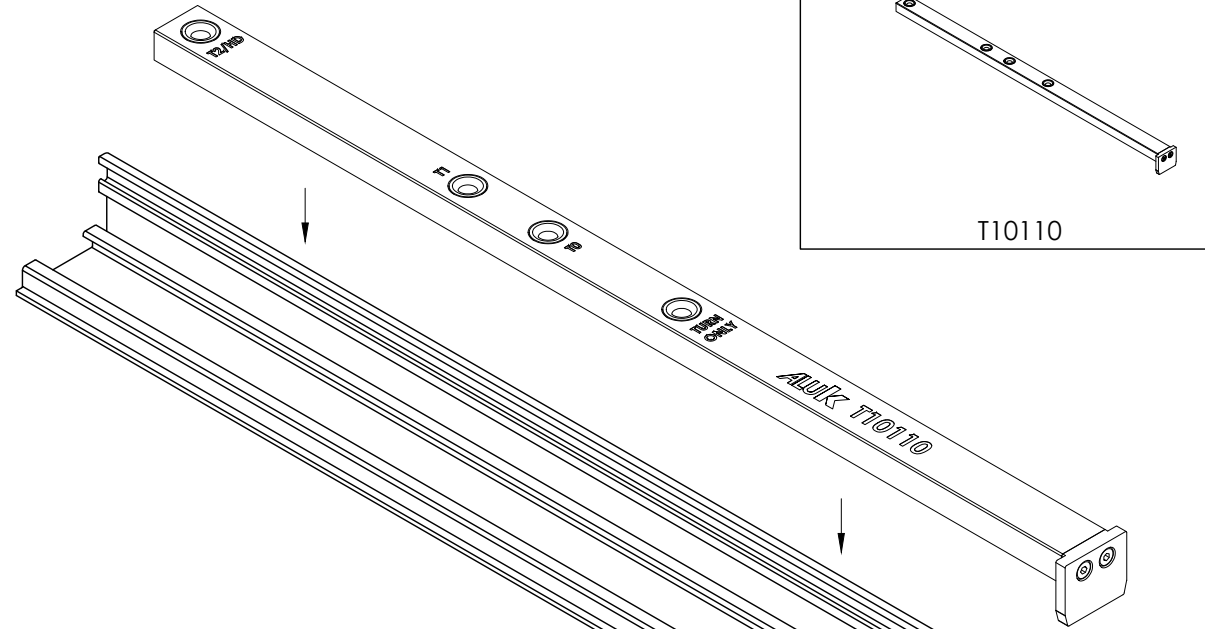
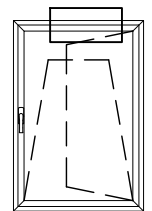
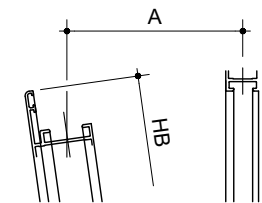
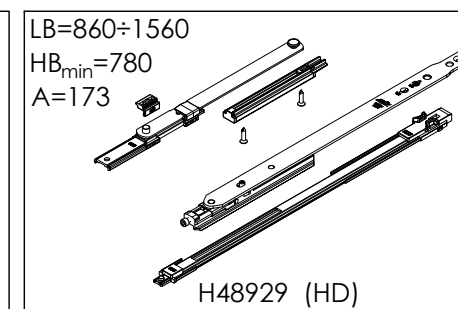
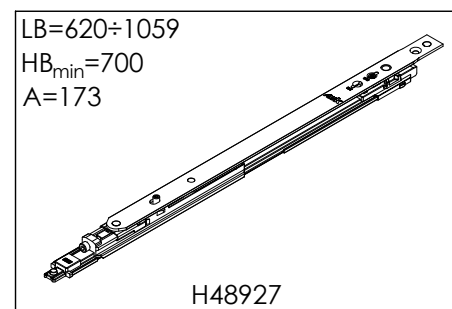
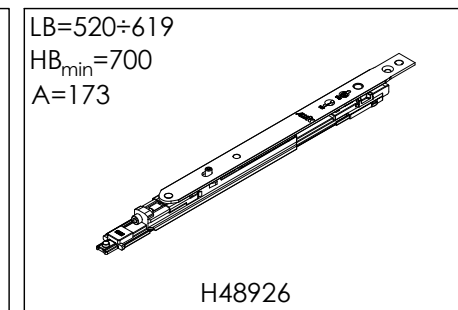
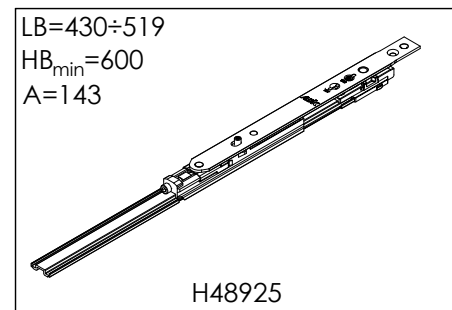
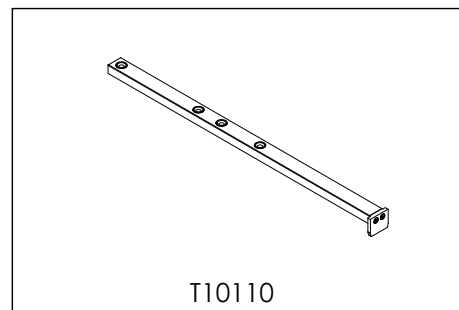

H48927 / H48929 - Forare Ø5 mm
H48927 / H48929 - Drill Ø5 mm

H48926 - Forare Ø5 mm
H48926 - Drill Ø5 mm

H48925 - Forare Ø5 mm
H48925 - Drill Ø5 mm

Posizionamento dima
Positioning the template

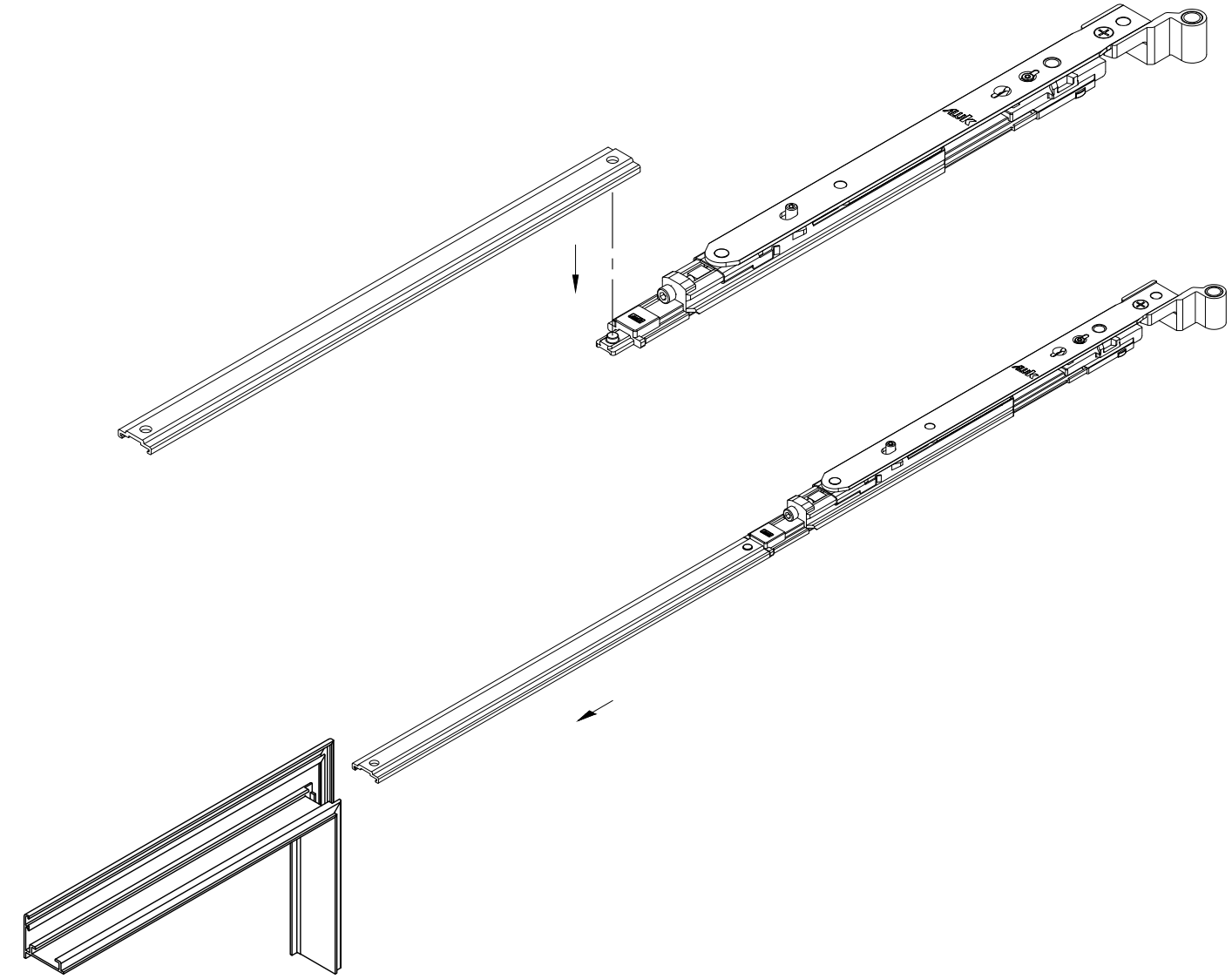
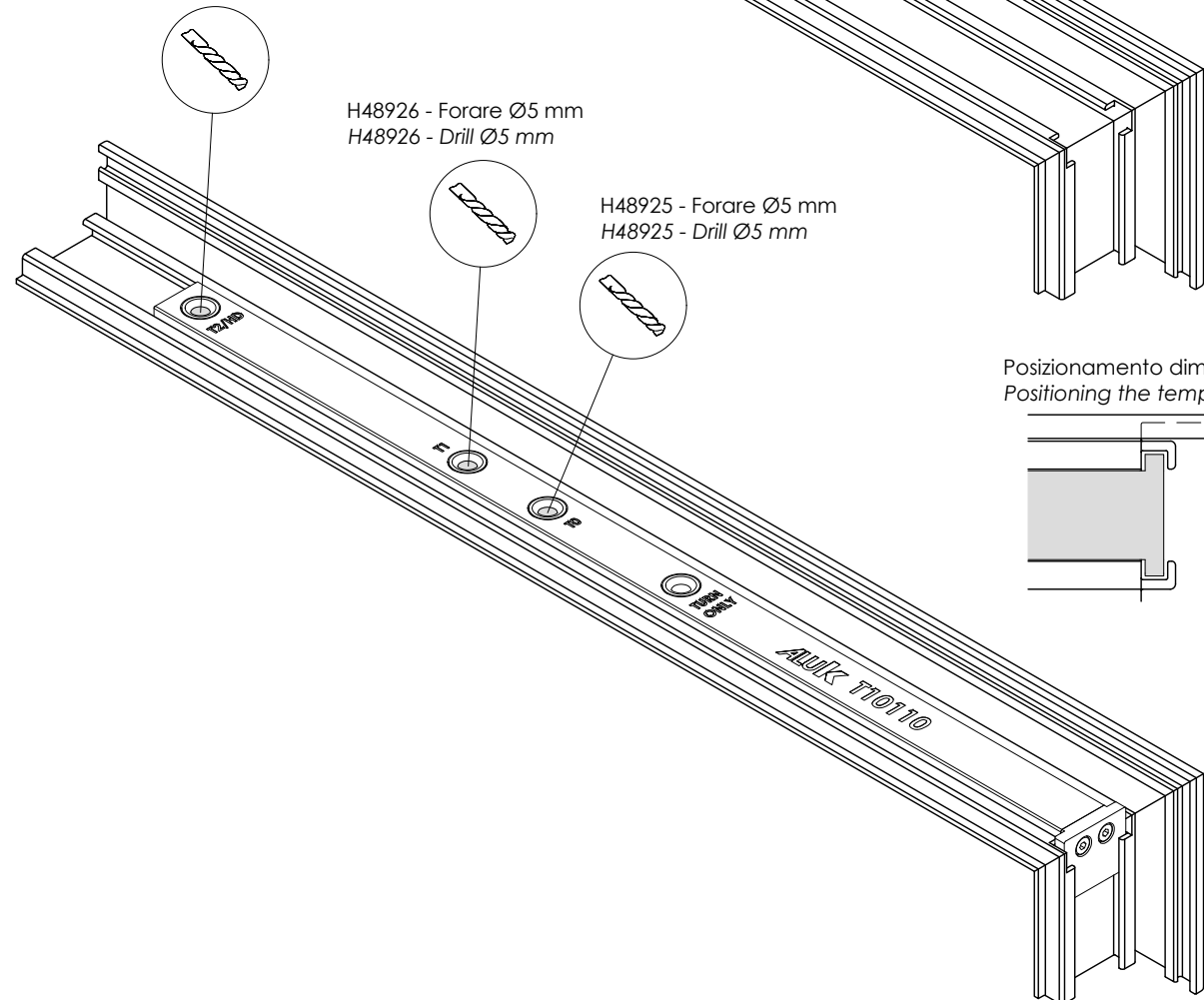
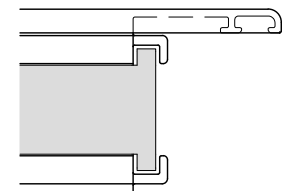

▶ MONTAGGIO BRACCIO ANTARIBALTA
TILT & TURN ARM ASSEMBLING

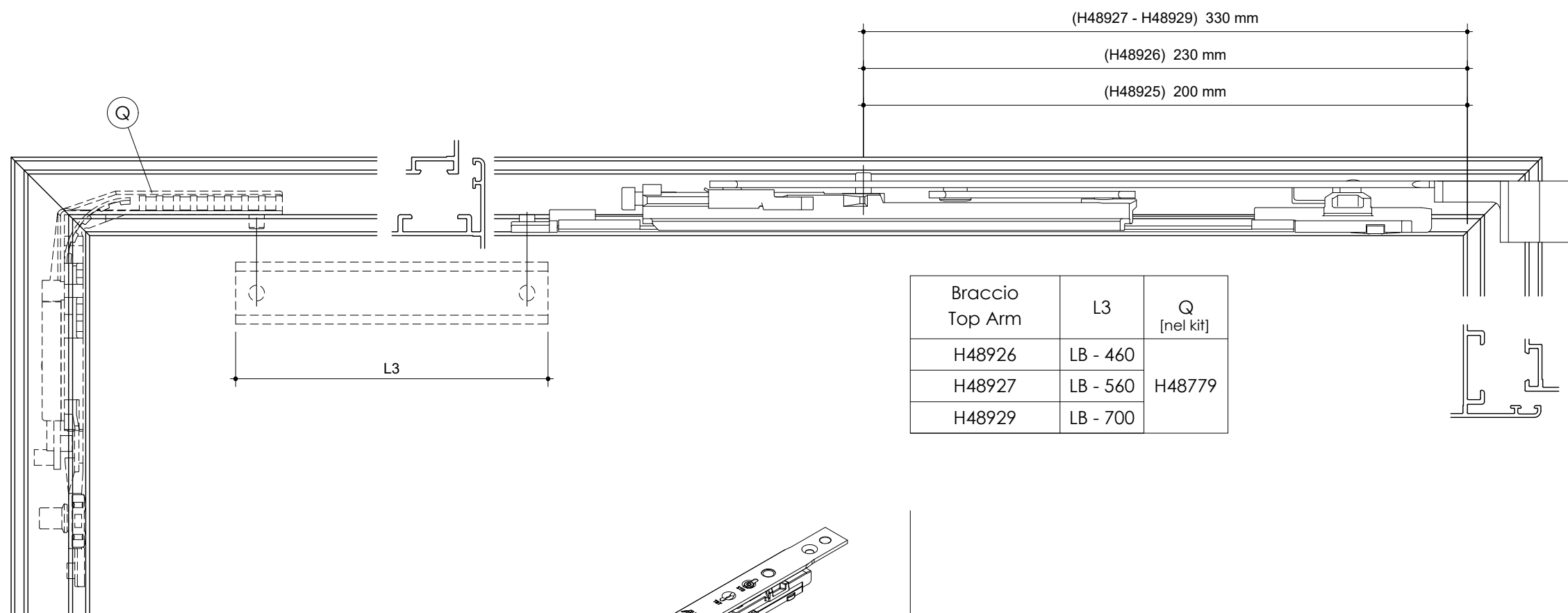
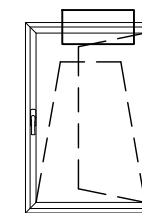

Braccio Top Arm	L3	Q [nel kit]
H48926	LB - 460	H48779
H48927	LB - 560	
H48929	LB - 700	

Lavorazione H48925
H48925 Machining

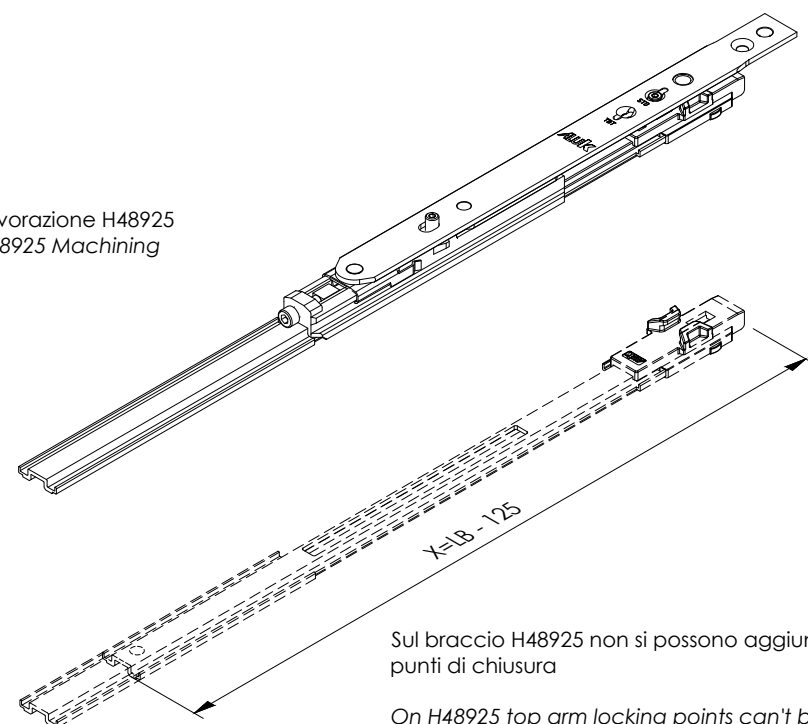
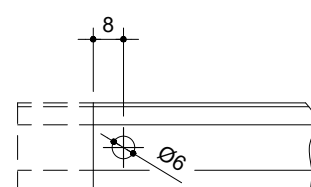

Sul braccio H48925 non si possono aggiungere punti di chiusura

On H48925 top arm locking points can't be added

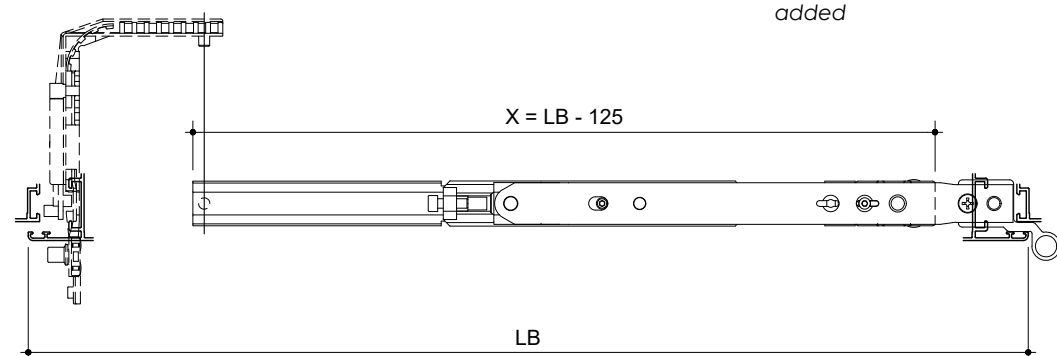

Modifica apertura STD / TBT
Operation modify STD / TBT

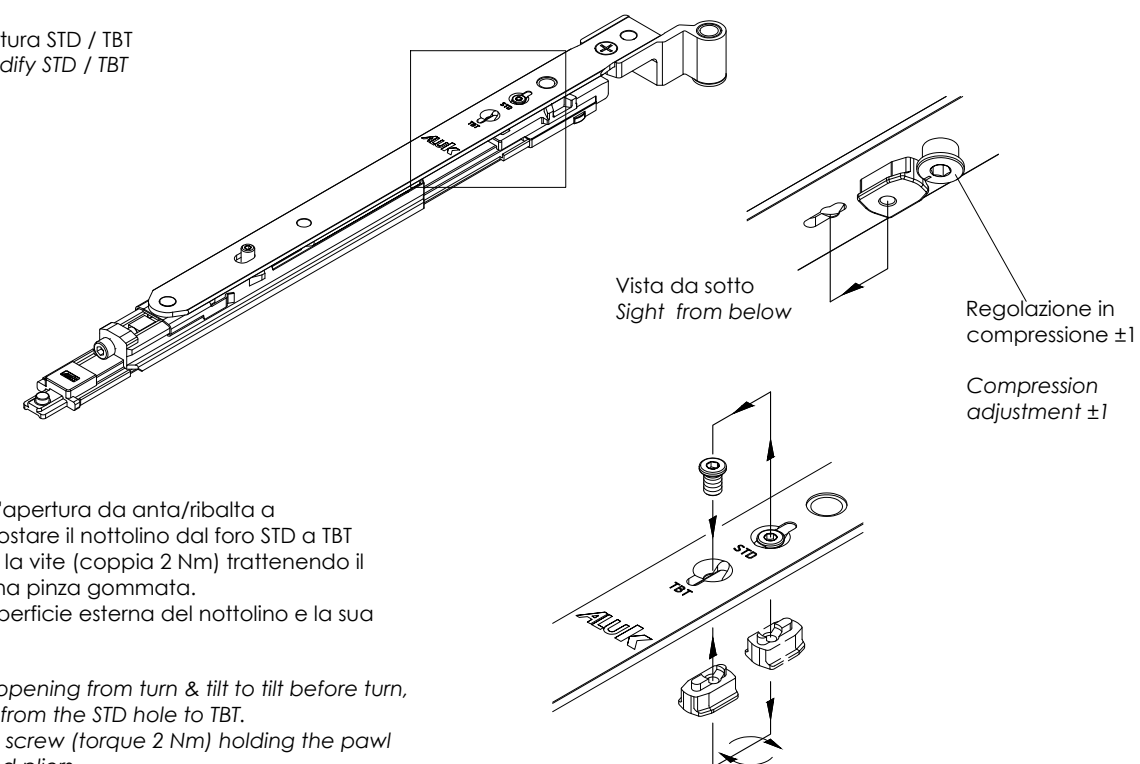

Per modificare l'apertura da anta/ribalta a ribalta/anta, spostare il nottolino dal foro STD a TBT. Serrare a fondo la vite (coppia 2 Nm) trattenendo il nottolino con una pinza gommata. Lubrificare la superficie esterna del nottolino e la sua sede in zama.

To change the opening from turn & tilt to tilt before turn, move the pawl from the STD hole to TBT. Fully tighten the screw (torque 2 Nm) holding the pawl with a rubberized pliers. Lubricate the external surface of the pawl and its striking point.

MONTAGGIO BRACCETTO SUPPLEMENTARE
ADDITIONAL ARM ASSEMBLING

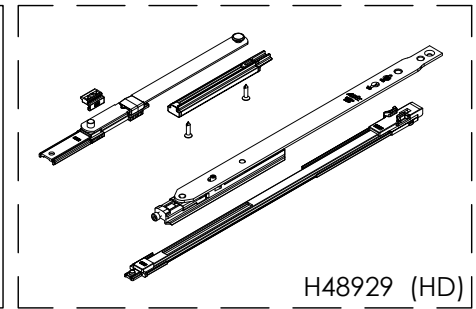
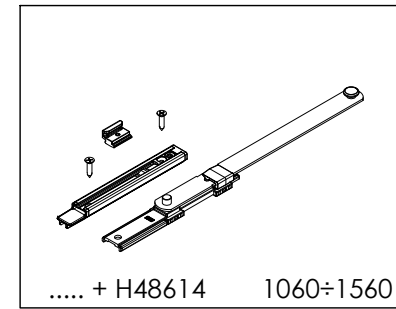
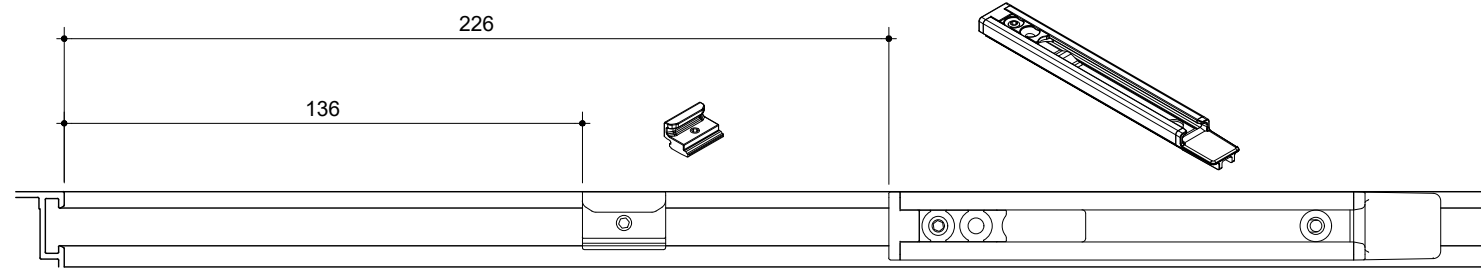
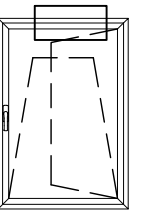

STD
Anta/Ribalta

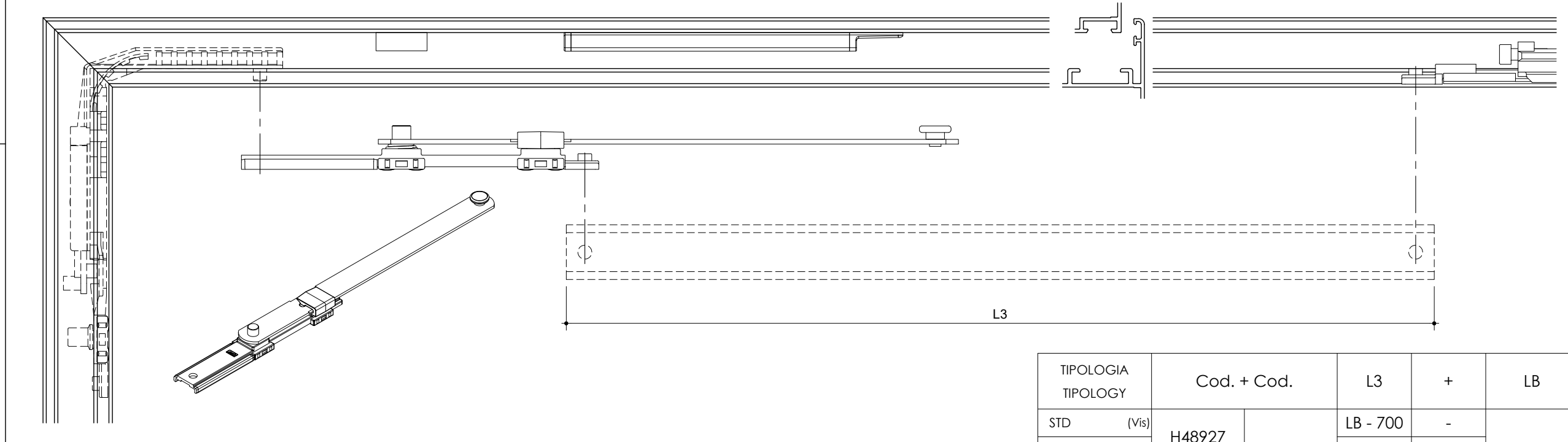

TIPOLOGIA TIPOLOGY		Cod. + Cod.	L3	+	LB
STD (Vis)	H48927	H48614	LB - 700	-	1060÷1560
TBT (Vis)			LB - 942	H48619	
STD (Nasc/Conc 100kg)	H48939/41	H48614	LB - 685	-	
TBT (Nasc/Conc 100kg)			LB - 934	H48619	
STD (Nasc/Conc 150kg)	H48943/45	H48614	LB - 685	-	
TBT (Nasc/Conc 150kg)			LB - 934	H48619	
STD (Vis)	H48929 (HD)	H48614	LB - 700	-	860÷1560
TBT (Vis)			LB - 942	H48619	

TBT
Ribalta/Anta

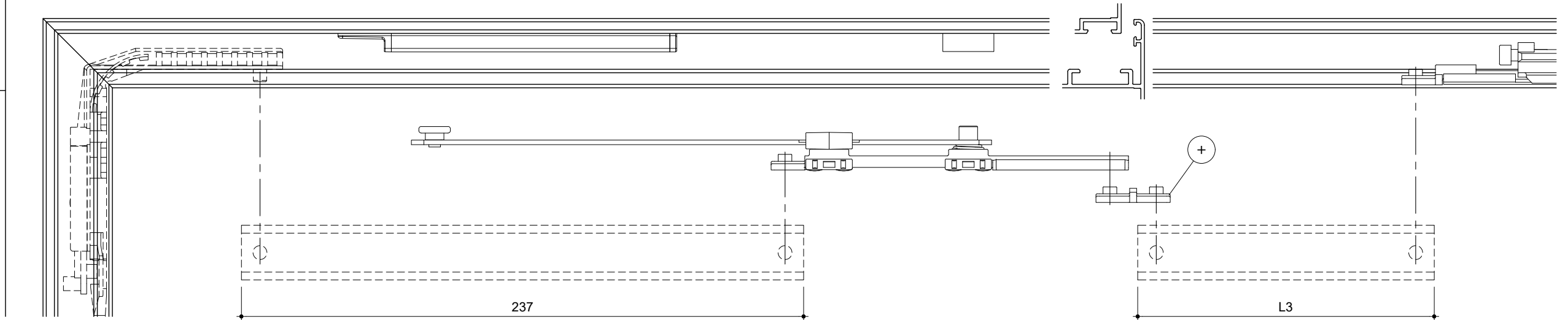
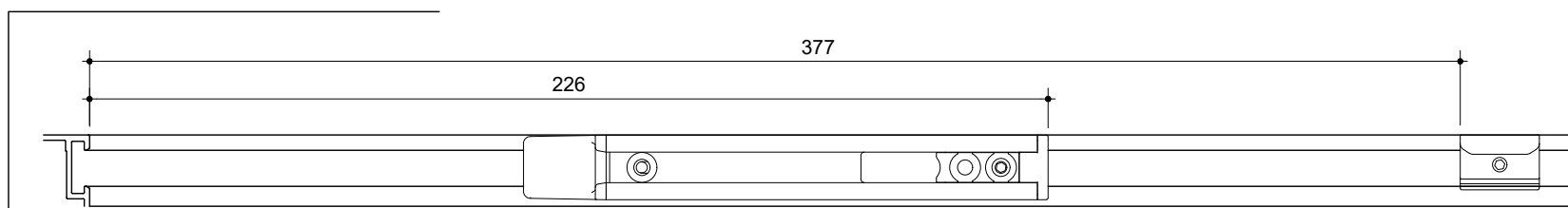
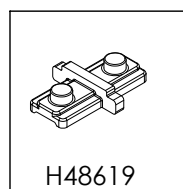

MONTAGGIO KIT BASE
STANDARD KIT ASSEMBLING

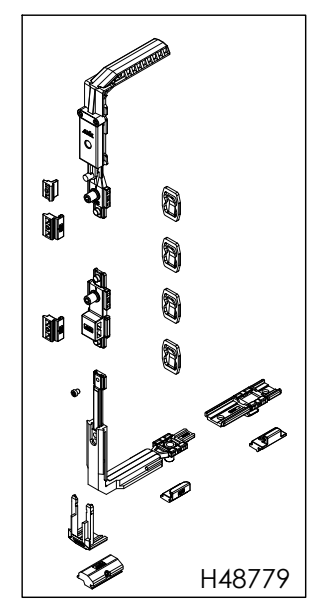
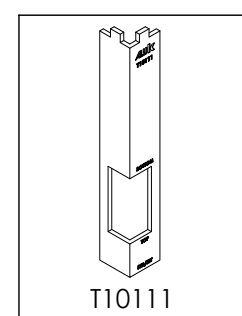
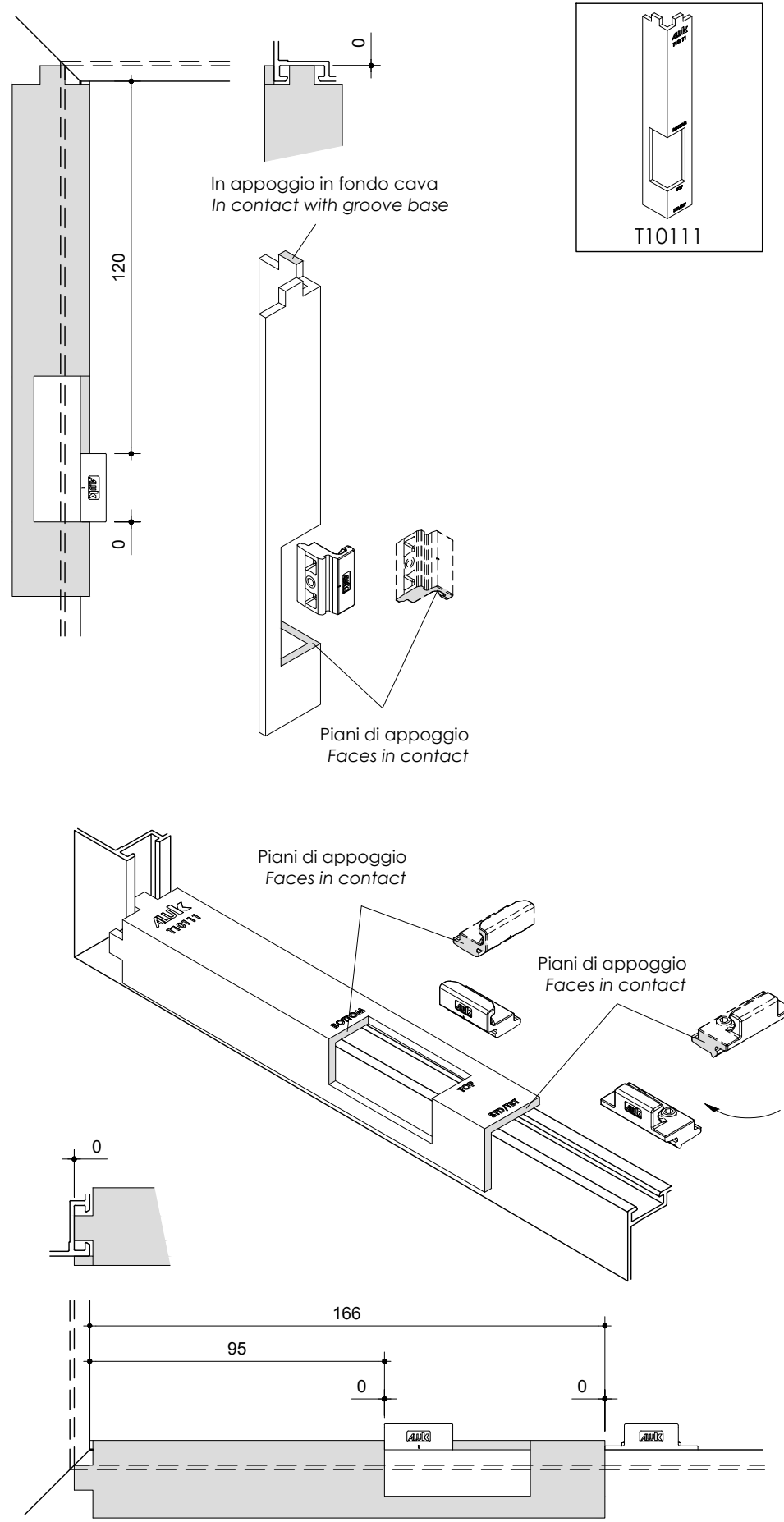
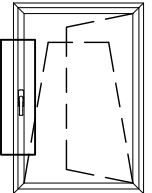

Posizionamento incontri
Striker positioning

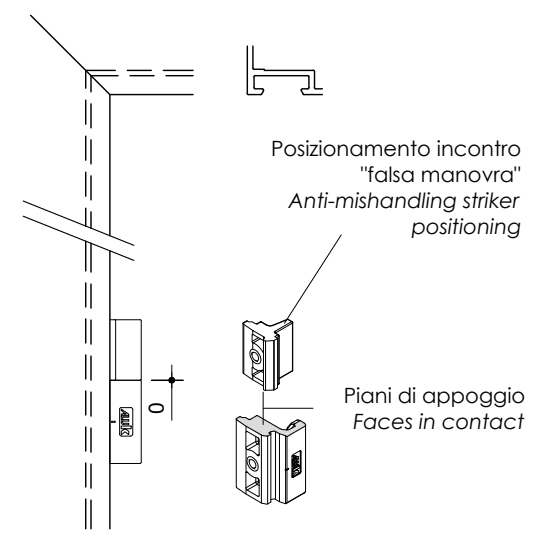

Posizionamento supporto anta su telaio
Sash support positioning on outer frame

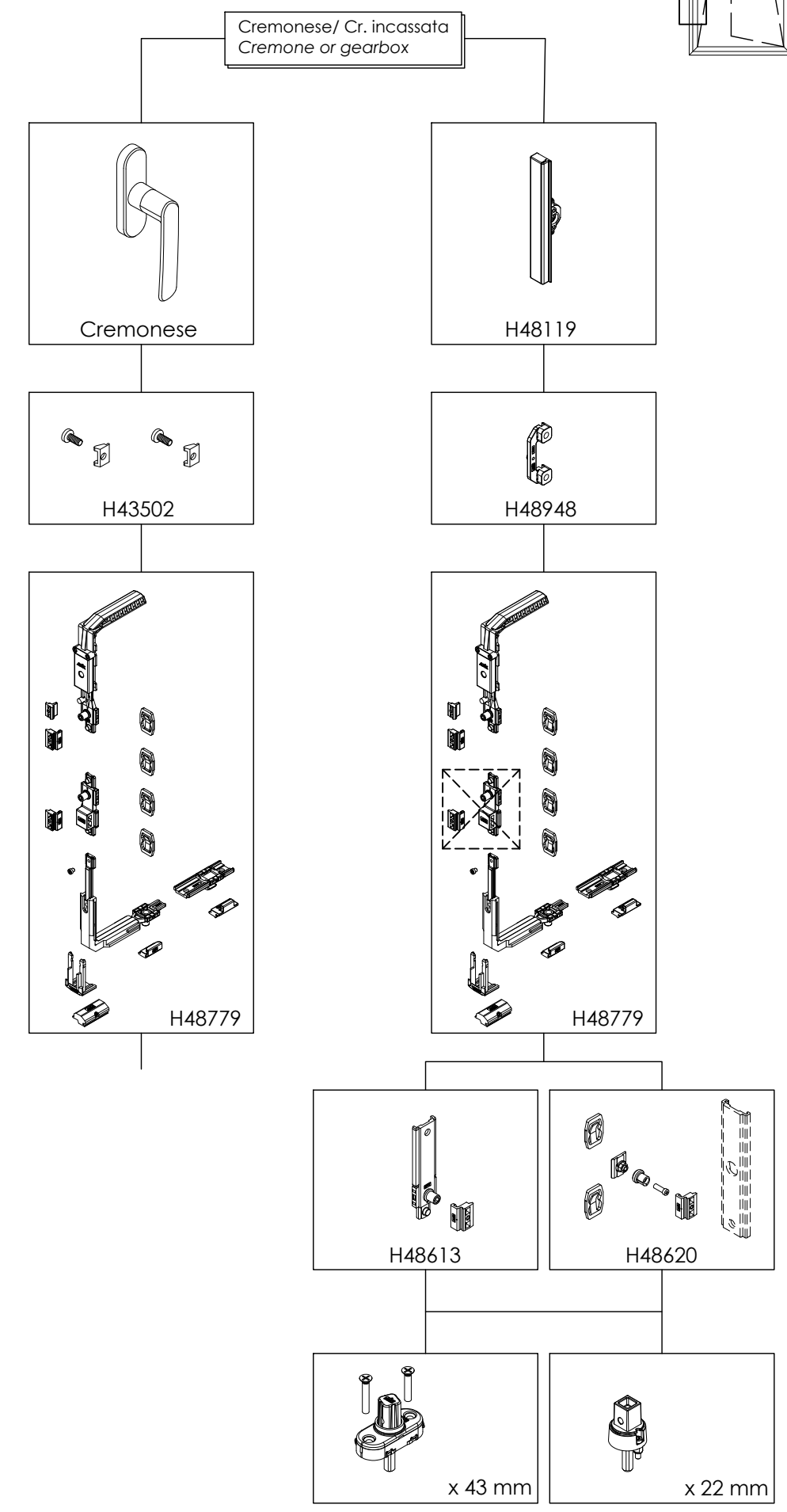
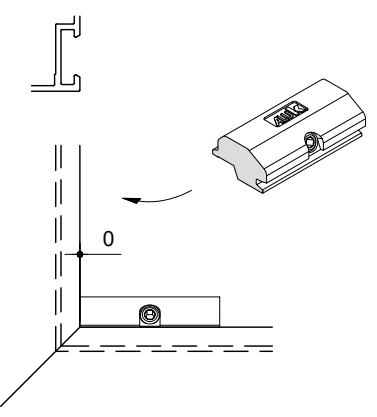

MONTAGGIO KIT BASE, LAVORAZIONE ASTE
STANDARD KIT ASSEMBLING, ROD MACHINING

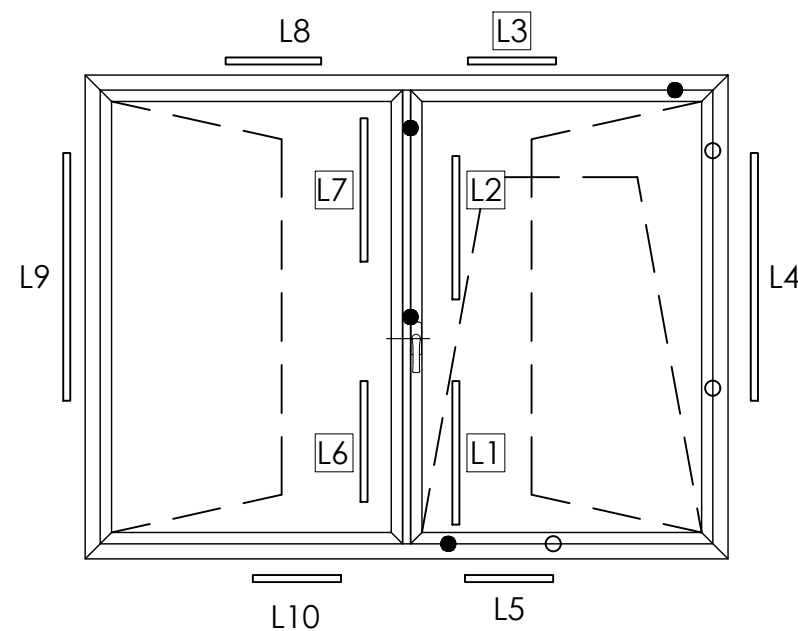
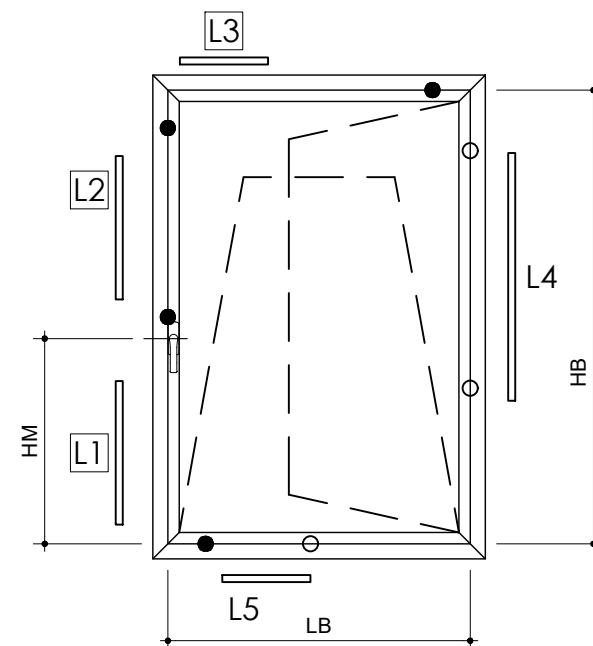
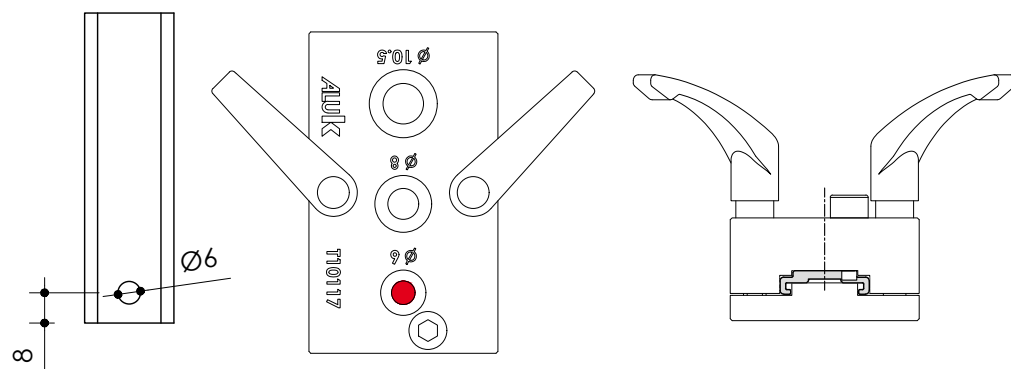
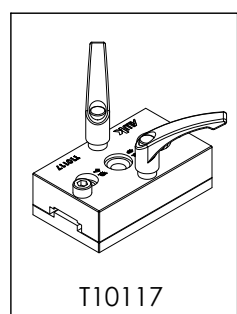

● Punti chiusura standard
 Standard locking points
 ○ Punti chiusura aggiuntivo
 Additional locking points

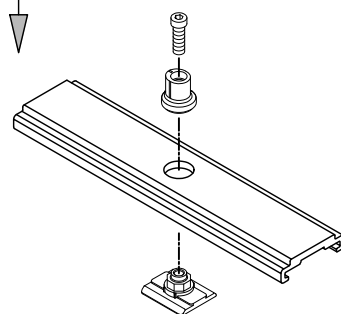
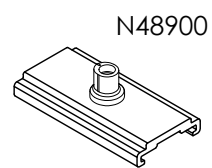
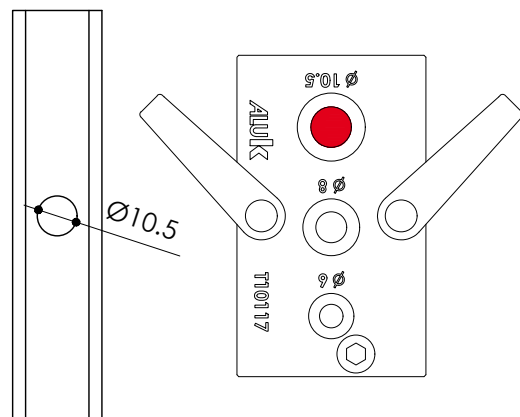
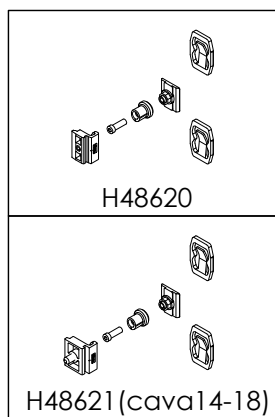
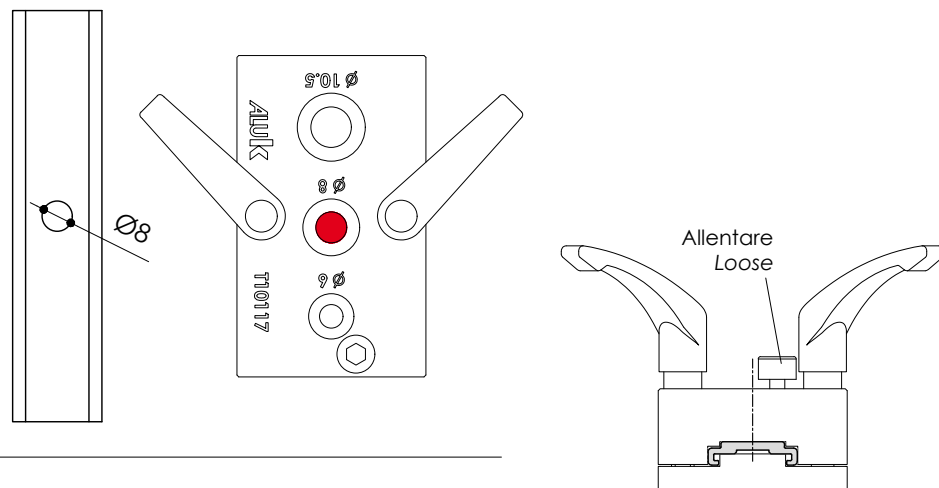
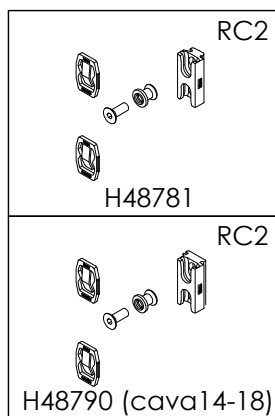
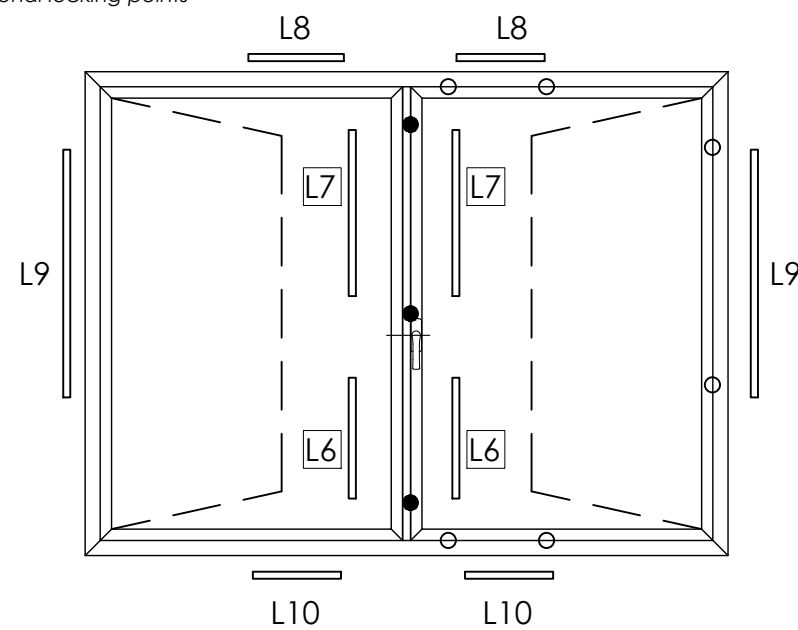
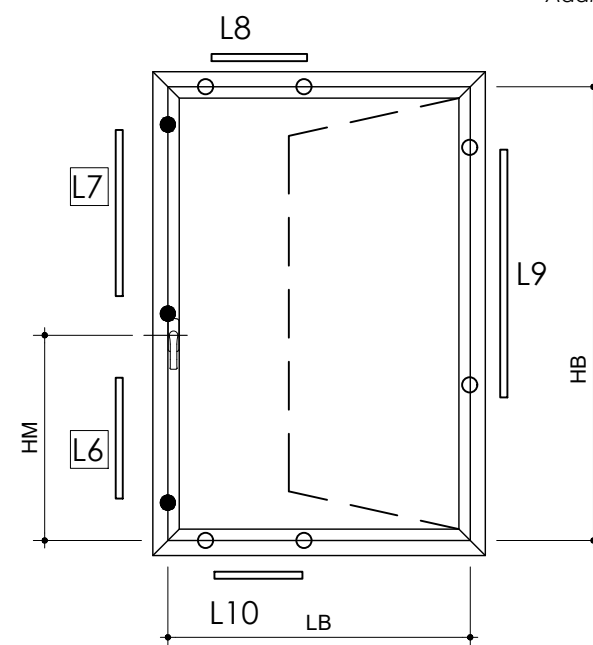

Montaggio punto di chiusura
 in "posizione 0"

Locking point assembling
 in "0 position"

Montaggio pattinini su asta di comando
Rod sliding blocks assembling

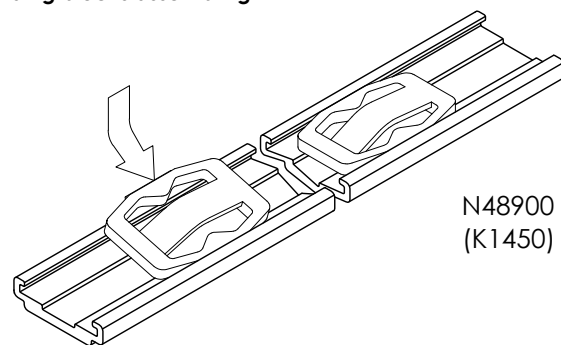

- L1 asta sotto maniglia anta/ribalta
- L2 asta sopra maniglia anta/ribalta
- L3 asta superiore anta/ribalta
- L4 asta lato cerniere anta/ribalta (opzionale)
- L5 asta inferiore anta/ribalta (opzionale)
- L6 asta sotto maniglia anta
- L7 asta sopra maniglia anta
- L8 asta superiore anta (opzionale)
- L9 asta lato cerniere anta (opzionale)
- L10 asta inferiore anta (opzionale)

- L1 tilt & turn rod below handle
- L2 tilt & turn rod over handle
- L3 tilt & turn top rod
- L4 tilt & turn hinge side rod (optional)
- L5 tilt & turn hinge bottom rod (optional)
- L6 turn-only rod below handle
- L7 turn-only rod over handle
- L8 turn-only top rod (optional)
- L9 turn-only hinge side rod (optional)
- L10 turn-only bottom rod (optional)

▶ TAGLIO ASTE LATO MANIGLIA ANTA/RIBALTA
 ROD CUTTING HANDLE SIDE TILT & TURN

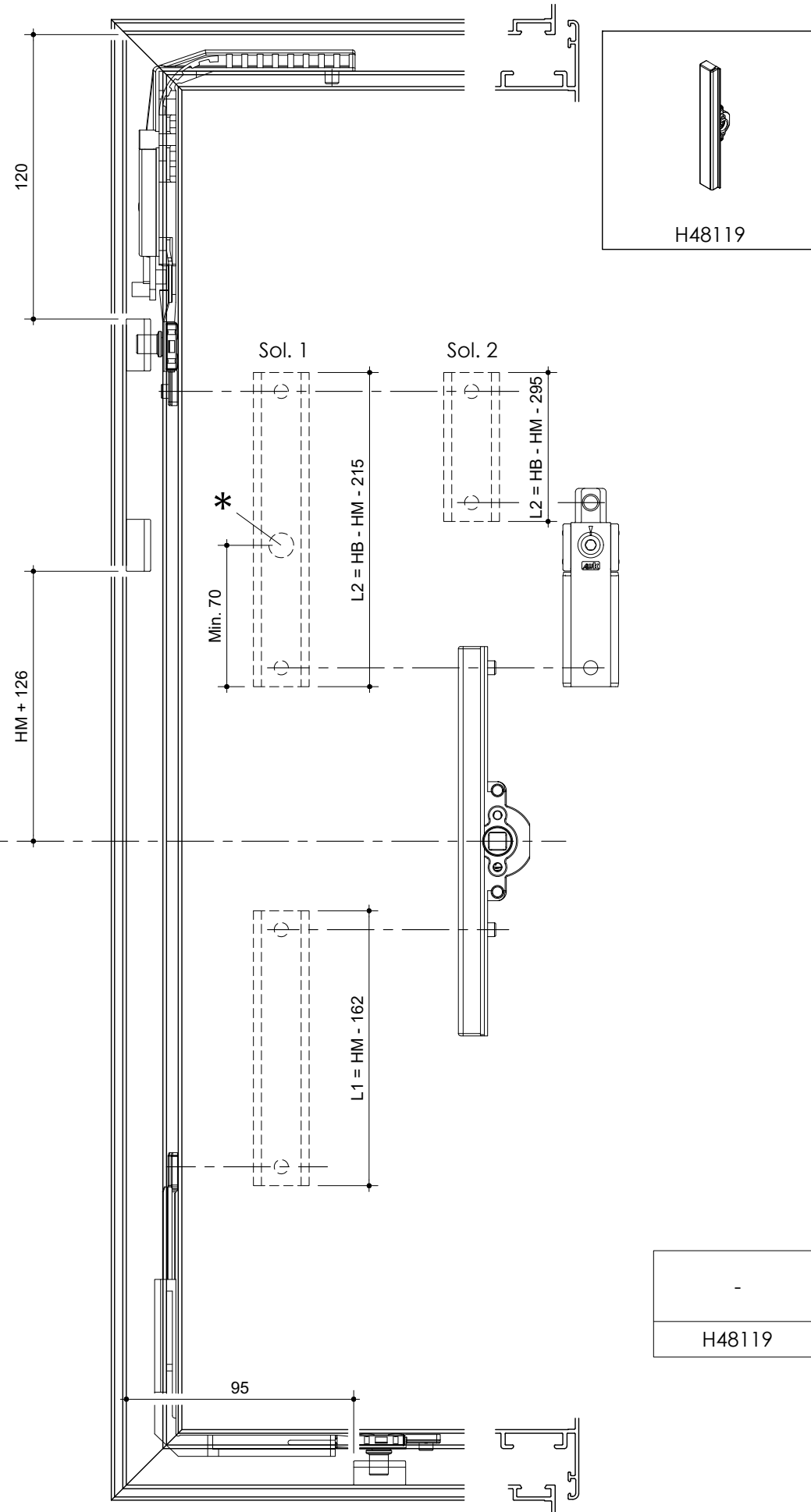
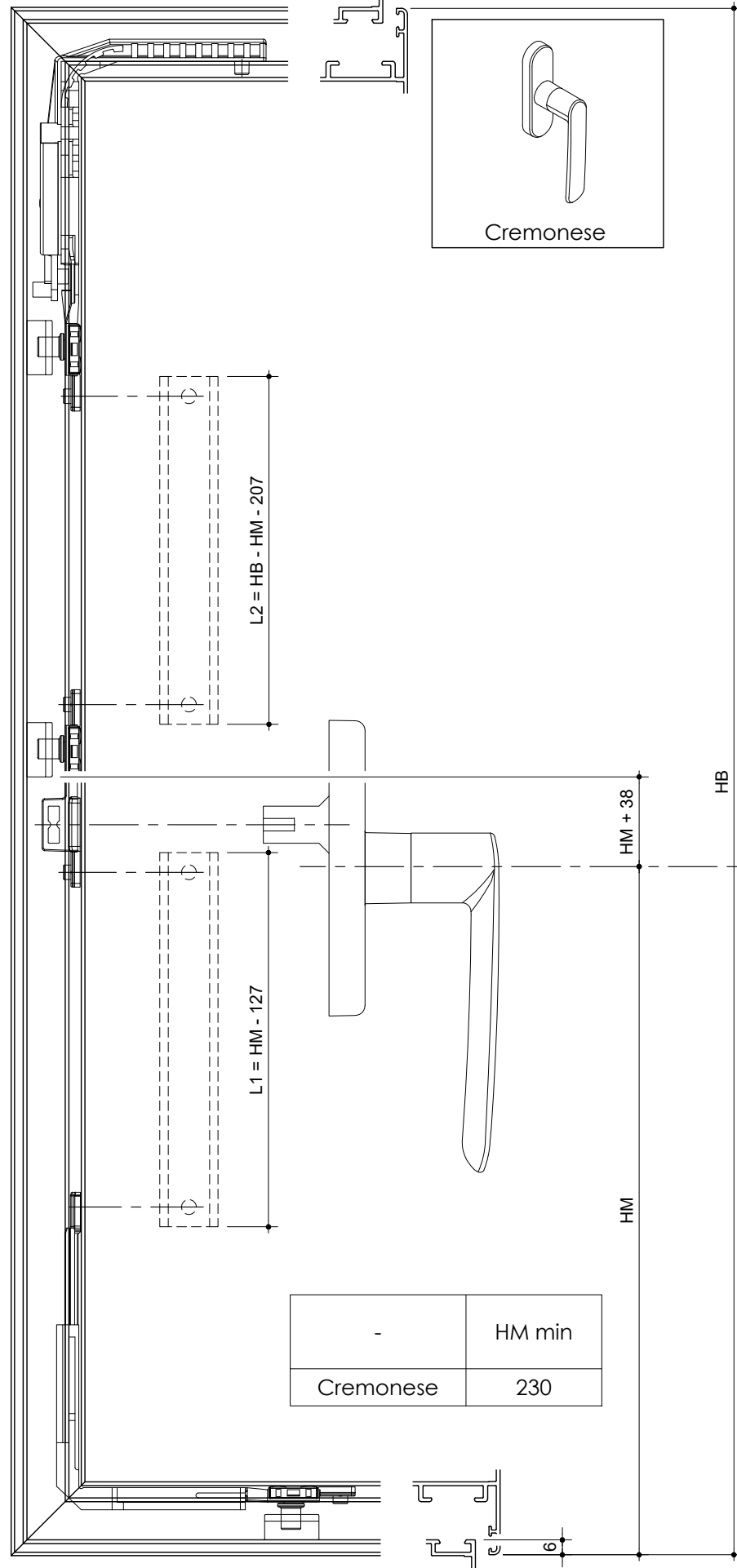
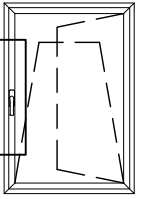

* Opzionale
 Optional

H48620

H48613

▶ TAGLIO ASTE LATO MANIGLIA ANTA-ANTA/RIBALTA
 ROD CUTTING HANDLE SIDE DOUBLE SASH TILT & TURN

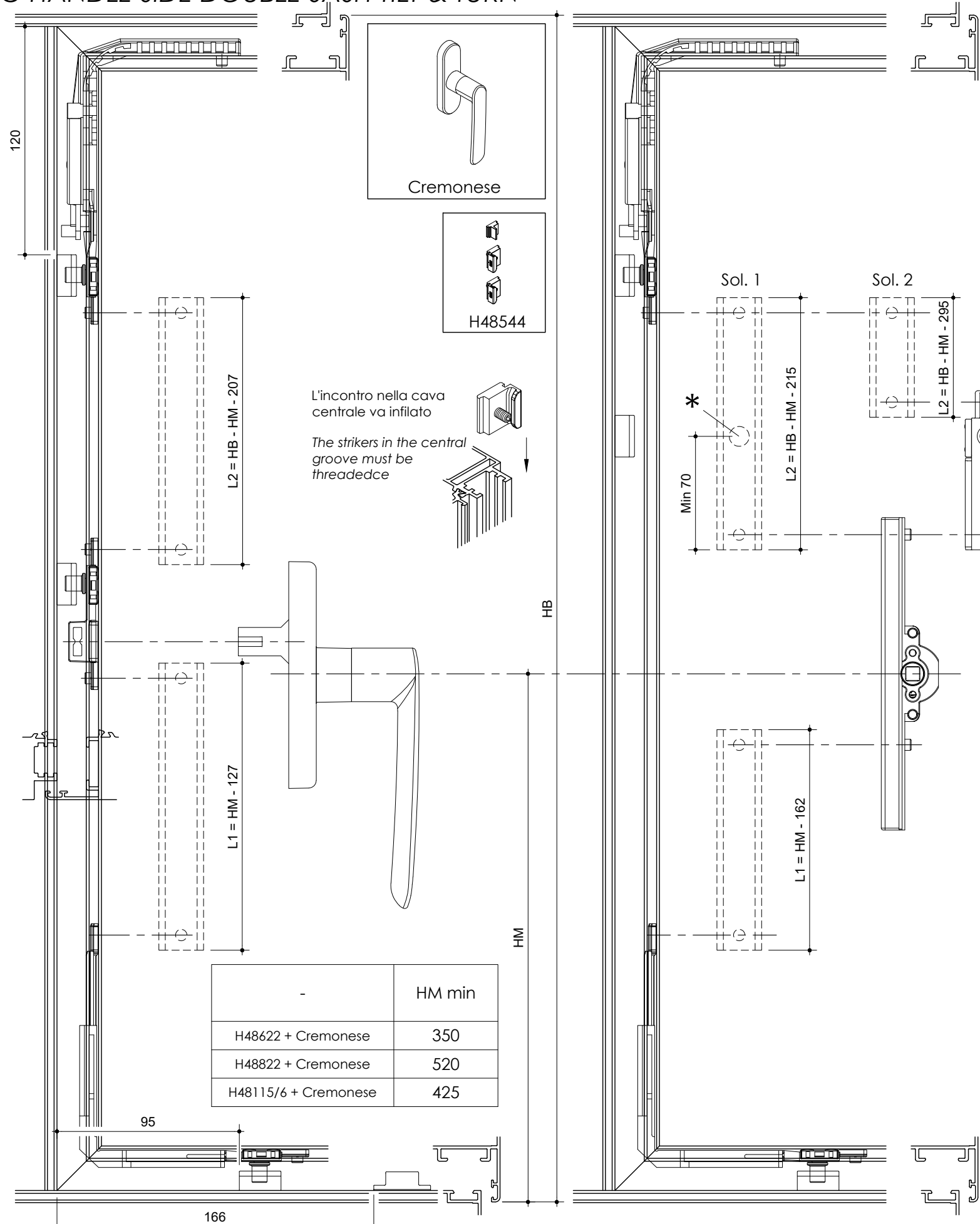
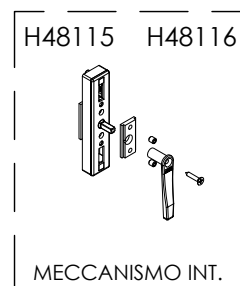
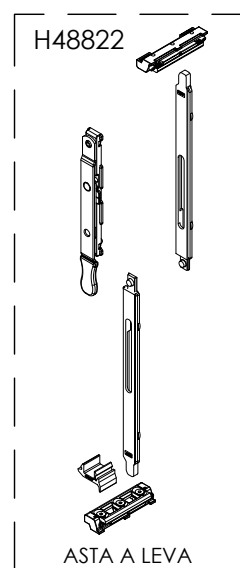
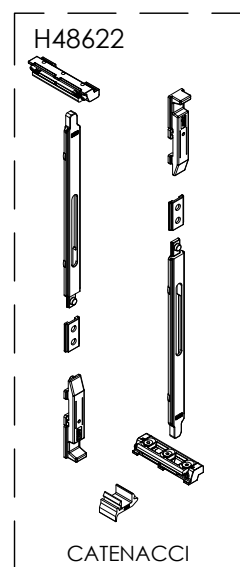
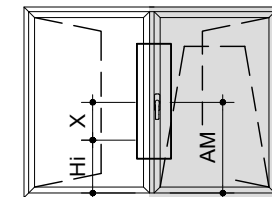

-	HM min
H48622 + Cremonese	350
H48822 + Cremonese	520
H48115/6 + Cremonese	425

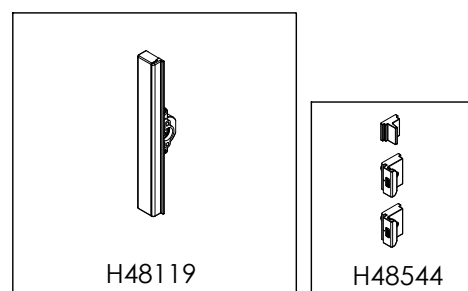

-	HM min
H48622 + H48119	390
H48822 + H48119	520
H48115/6 + H48119	425

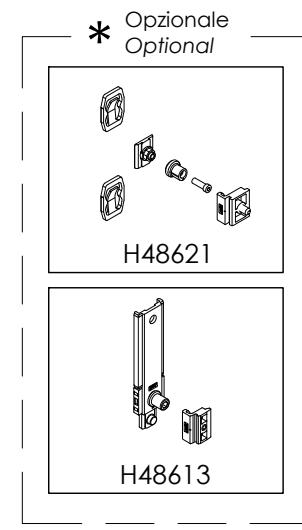

MONTAGGIO RINVIO D'ANGOLO KIT BASE STANDARD KIT CORNER TRANSMISSION ASSEMBLING

Per aperture anta/ribalta (STD)
For tilt & turn opening

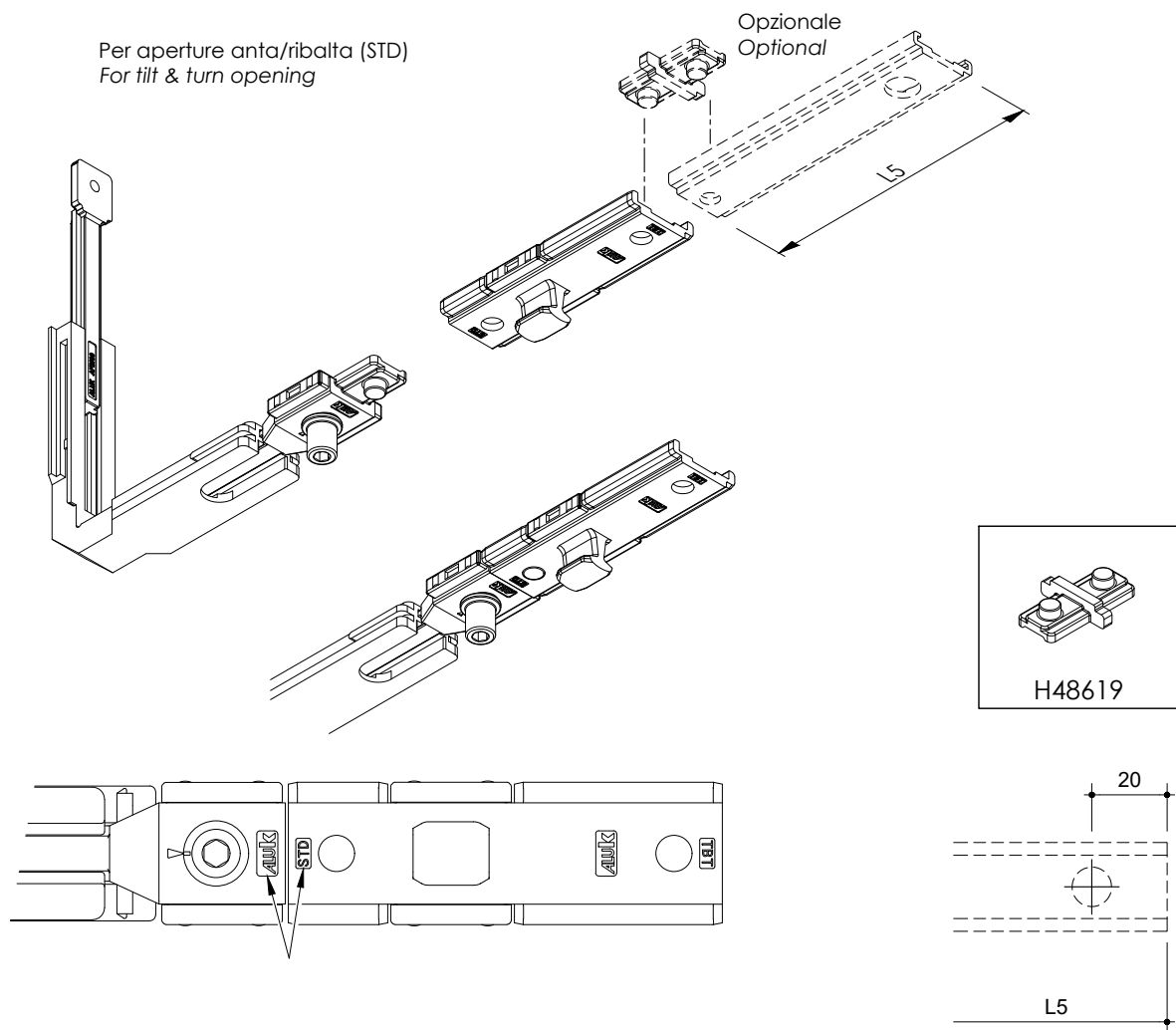

Per aperture ribalta/anta (TBT)
For tilt before turn opening

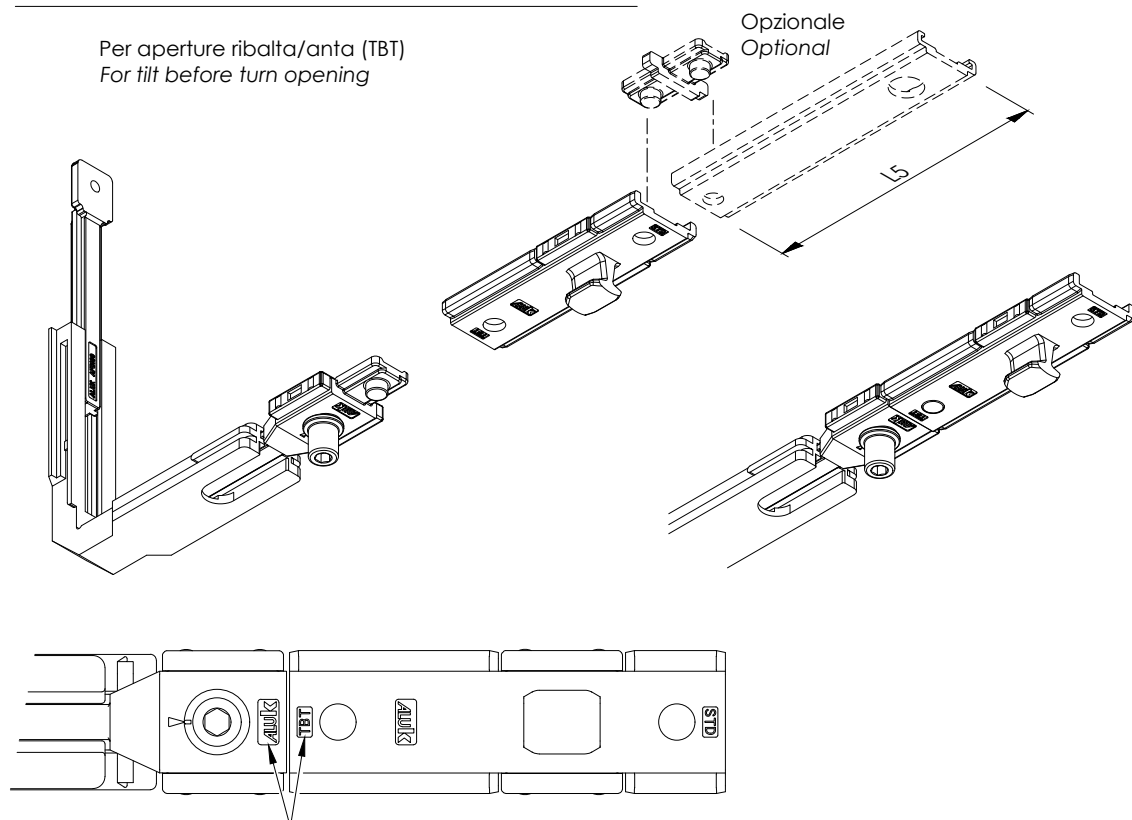

Montaggio rinvio d'angolo inferiore
Lower corner transmission assembling

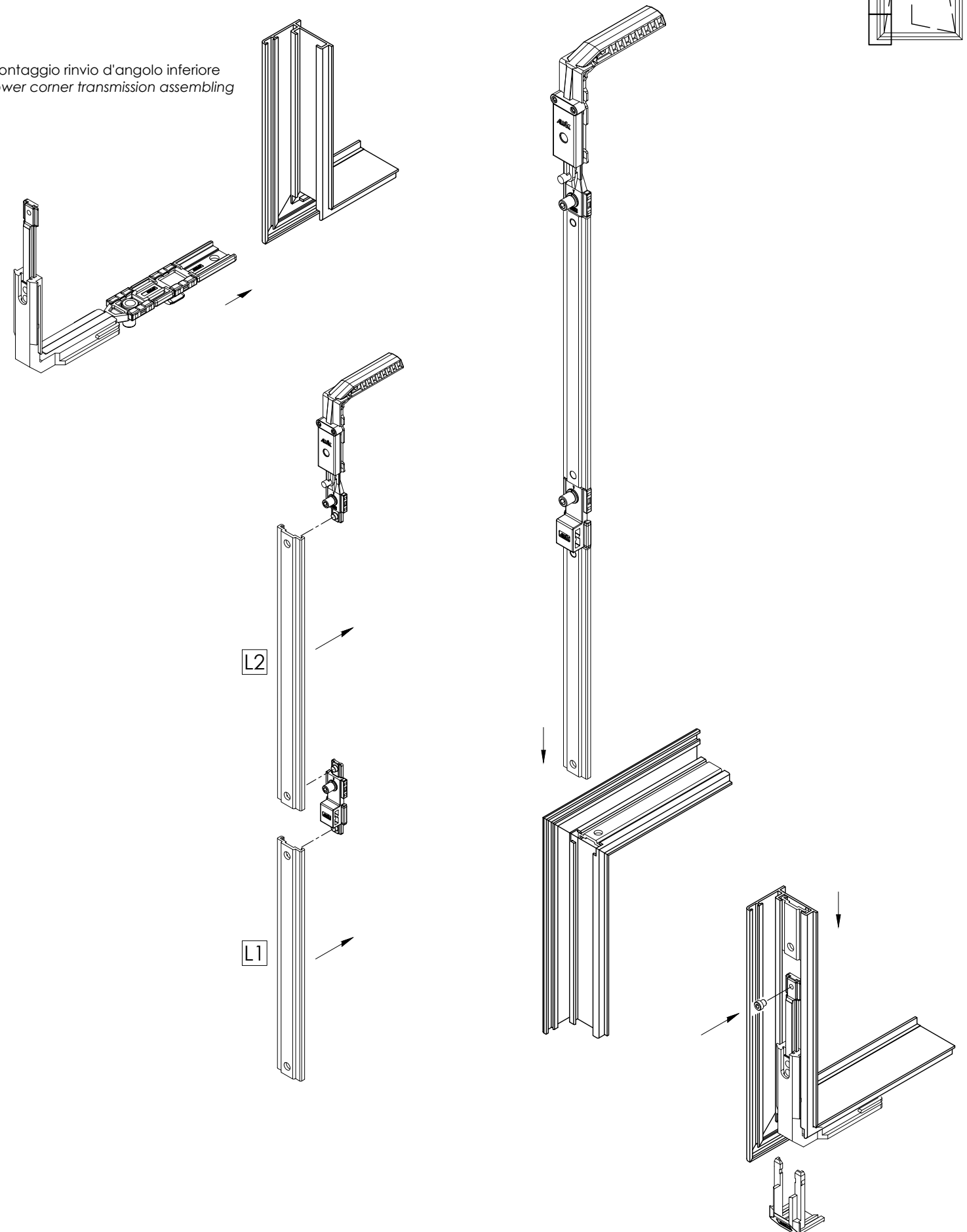

MONTAGGIO PUNTI DI CHIUSURA AGGIUNTIVI
ADDITIONAL LOCKING POINTS ASSEMBLING

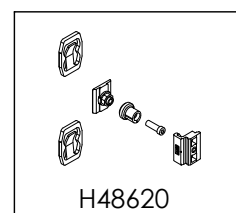
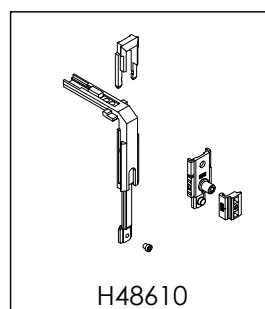
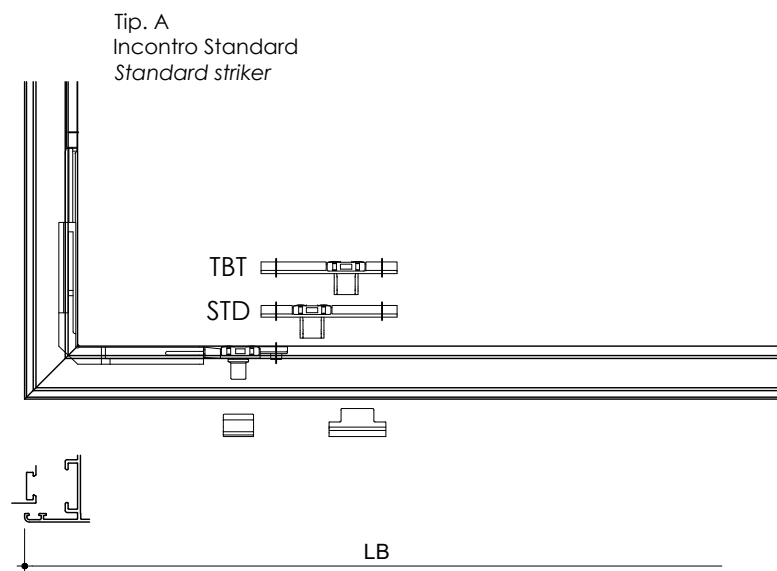
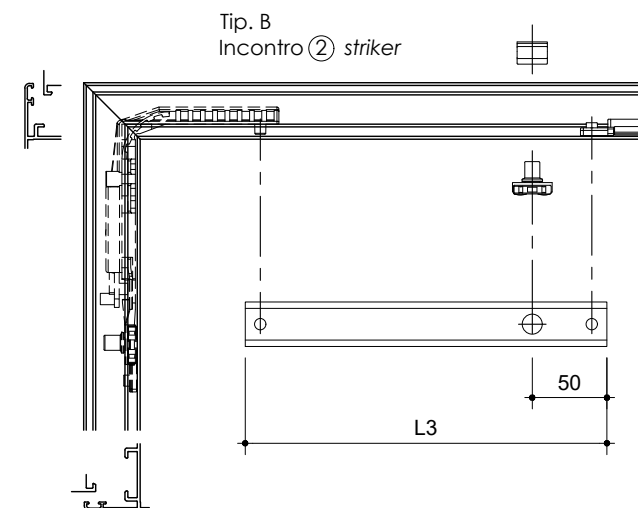
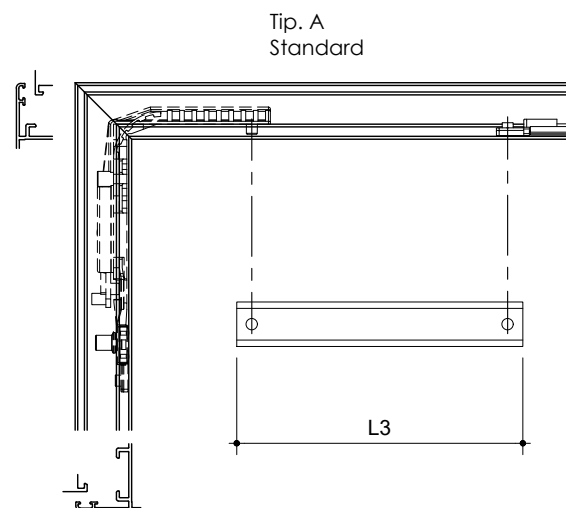
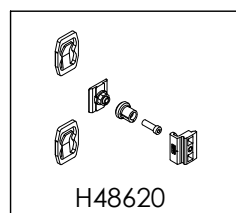
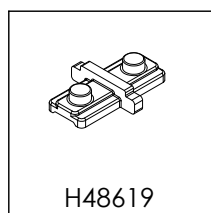
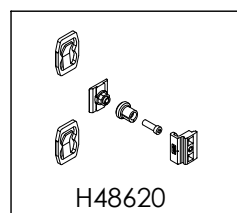
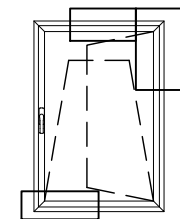

Tip. A
Incontro Standard
Standard striker

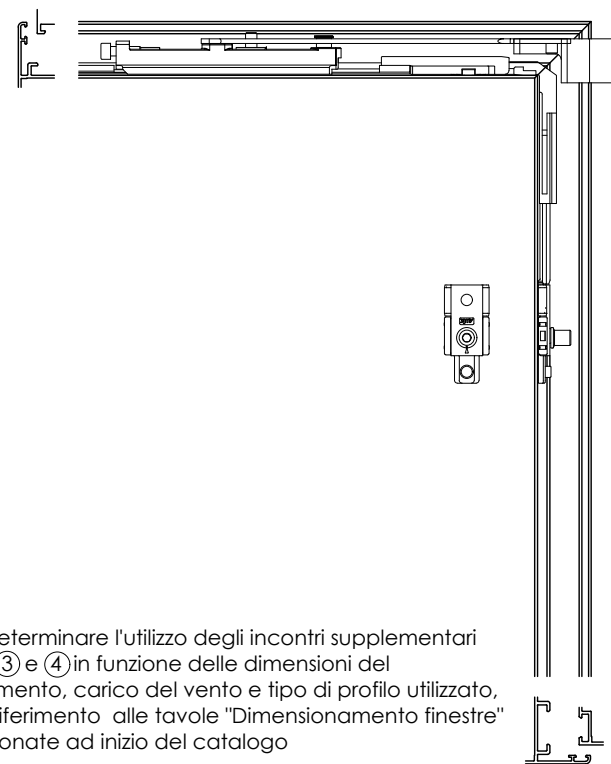

Tip. B
Incontro ① striker

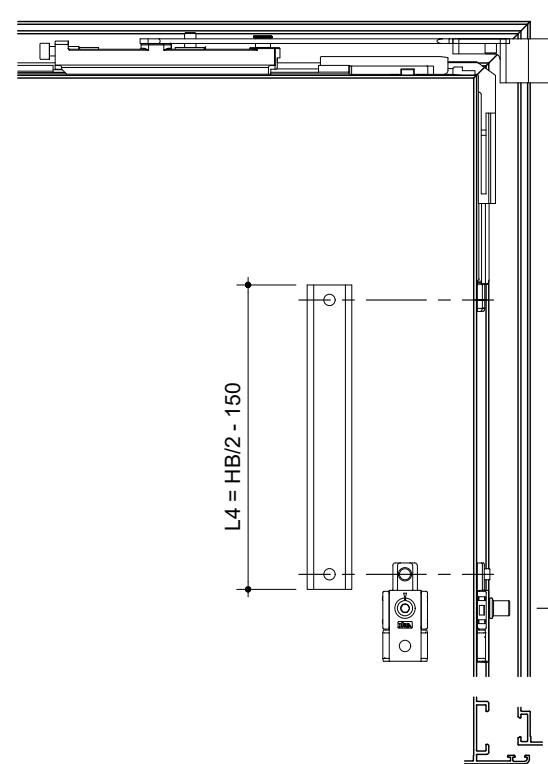

Tip. C
Incontro ④ striker

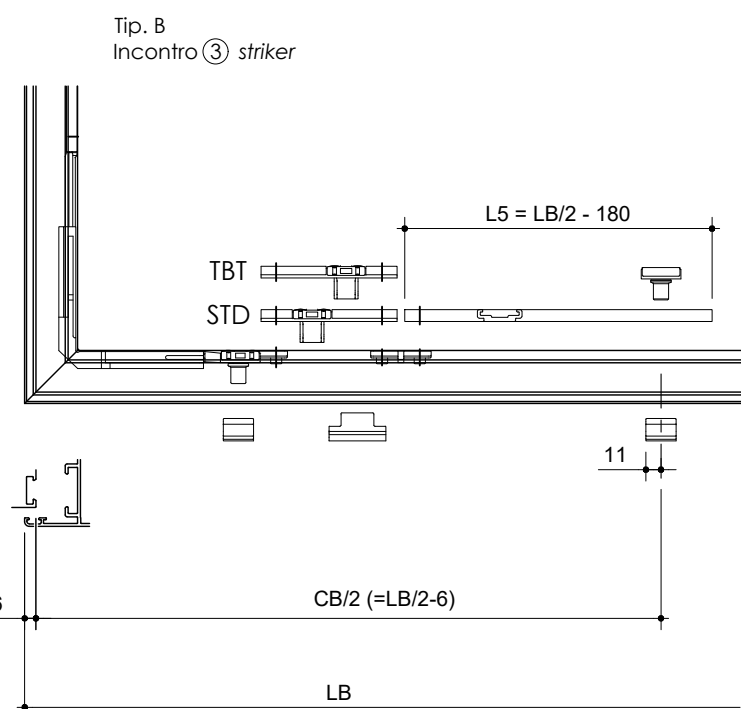
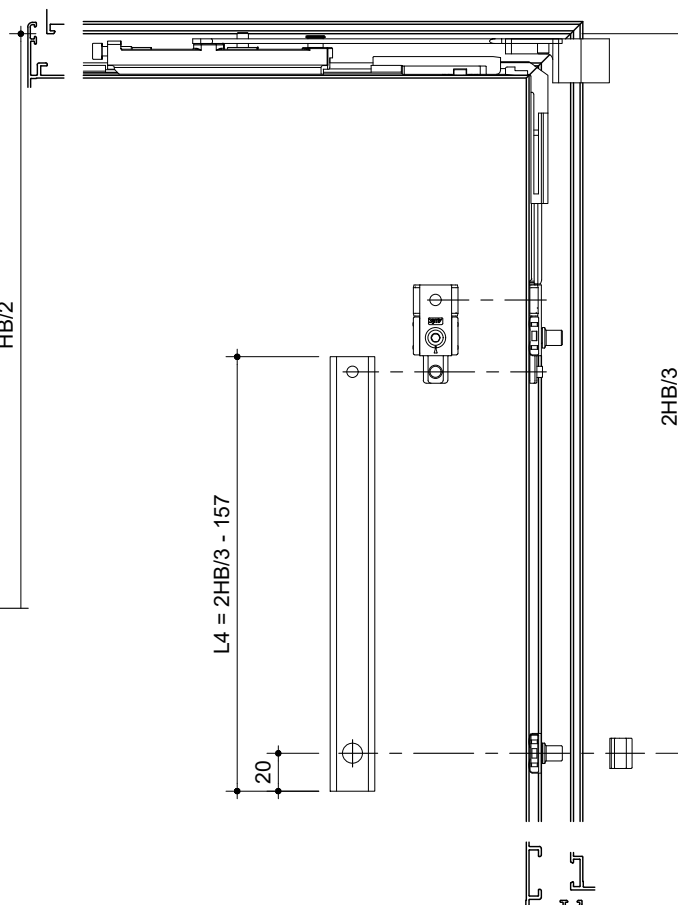

Per determinare l'utilizzo degli incontri supplementari ①②③ e ④ in funzione delle dimensioni del serramento, carico del vento e tipo di profilo utilizzato, fare riferimento alle tavole "Dimensionamento finestre" posizionate ad inizio del catalogo

To determine the use of additional strikers ①②③ and ④ based on the size of the window, wind load and type of profile used, refer to the "Size limits" tables located at the beginning of the catalogue

MONTAGGIO CERNIERE DUE ALI 80 kg
80 kg TWO-PART HINGE ASSEMBLING

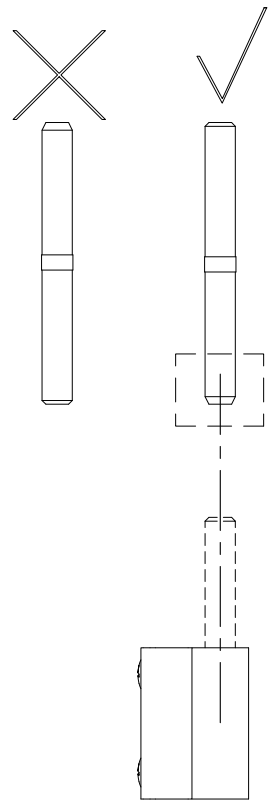
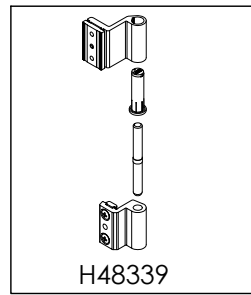

Inserire il perno fino al filo inferiore cerniera
 Insert the pin till the lower edge of the hinge

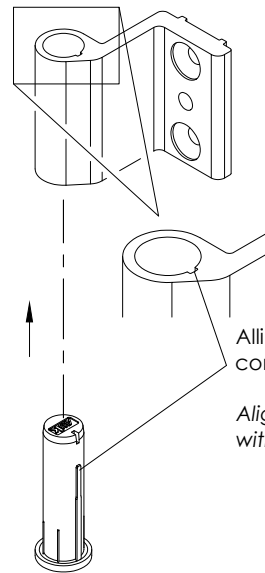
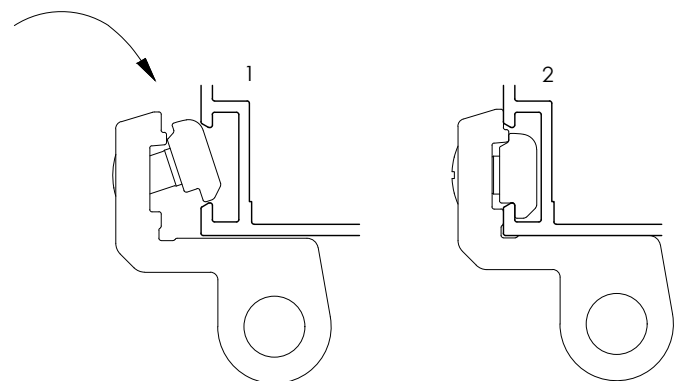

Allineare la nervatura della boccia,
 con lo scarico nel foro della semicerniera battente.
 Align the rib of the bushing,
 with the relief in the hole of the vent half-hinge.

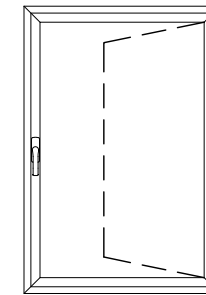
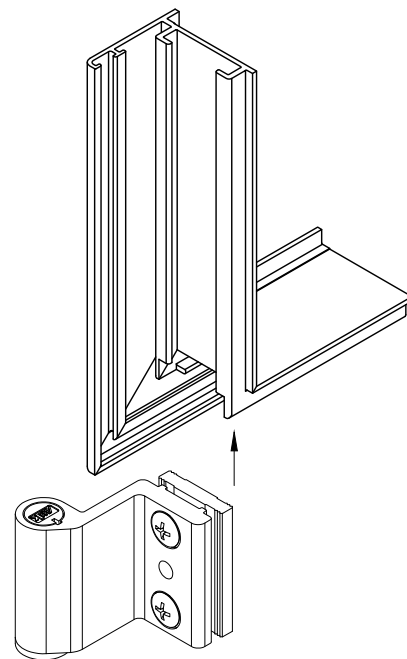

Posizionare la cerniera agli estremi
 Montare una cerniera centrale per HB > 1800 mm
 (con carico di vento 800 Pa)

Position the hinge at the ends
 Mount a central hinge for HB > 1800 mm
 (wind load 800 Pa)

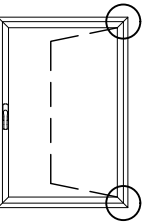

Una volta posizionata la cerniera, serrare i grani
 Once the hinge is in place, tighten the grub screws

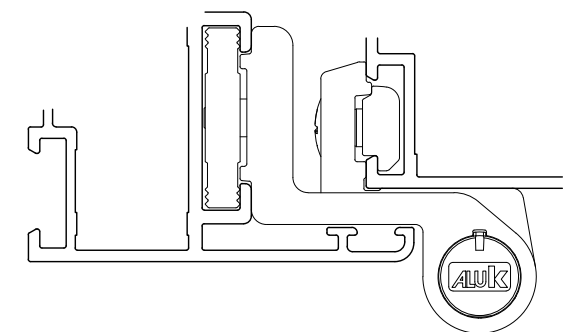
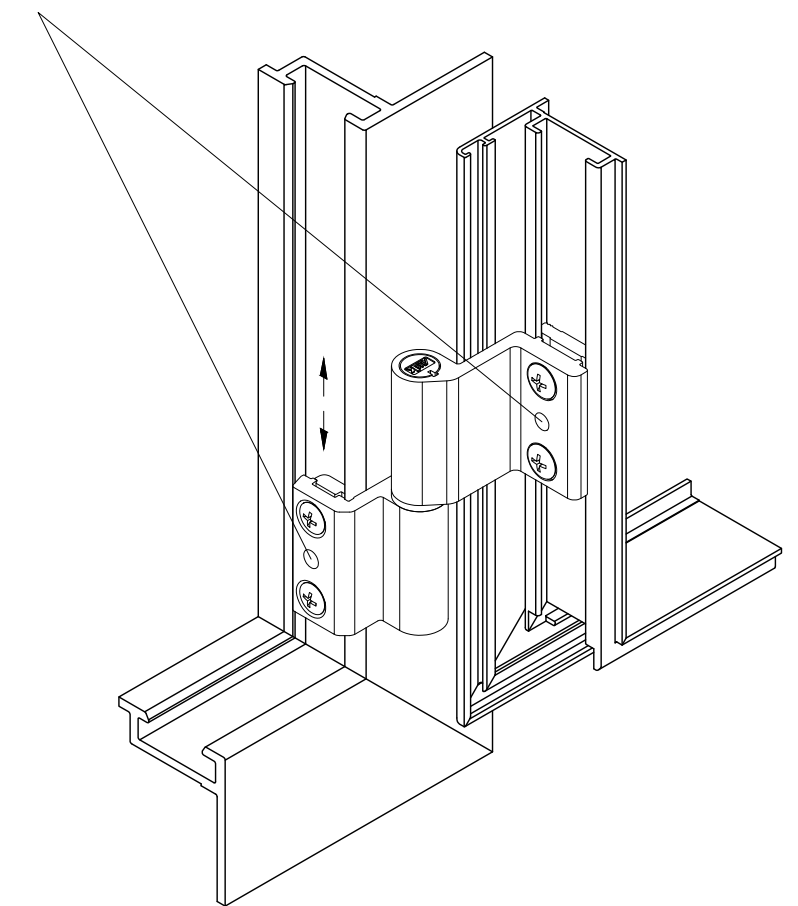

➤ MONTAGGIO CERNIERE PETTINE 100 kg
100 kg THREE-PART HINGES ASSEMBLING

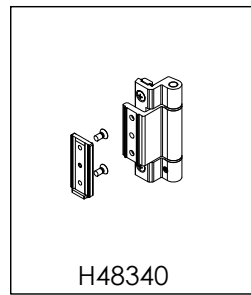

Una volta posizionata la cerniera, serrare i grani
Once the hinge is in place, tighten the grub screws

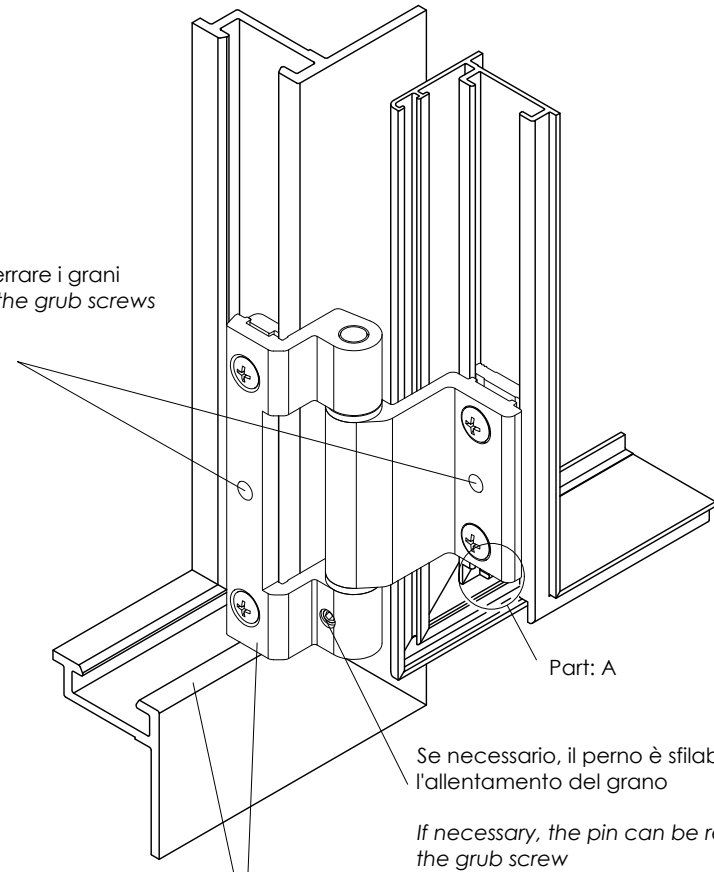

Part: A

Se necessario, il perno è sfilabile mediante l'allentamento del grano
If necessary, the pin can be removed by loosening the grub screw

If necessary, the pin can be removed by loosening the grub screw

Appoggiare allo stipite la cerniera inferiore
Seat lower hinge on fixed frame

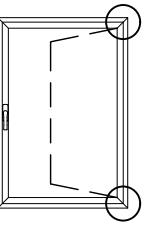
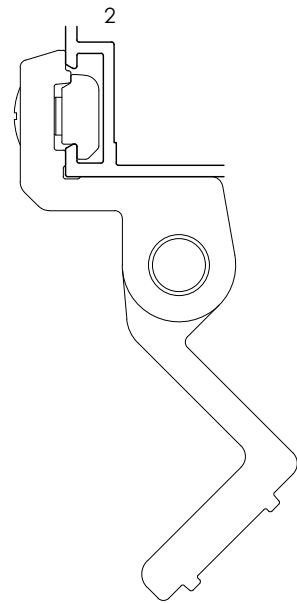
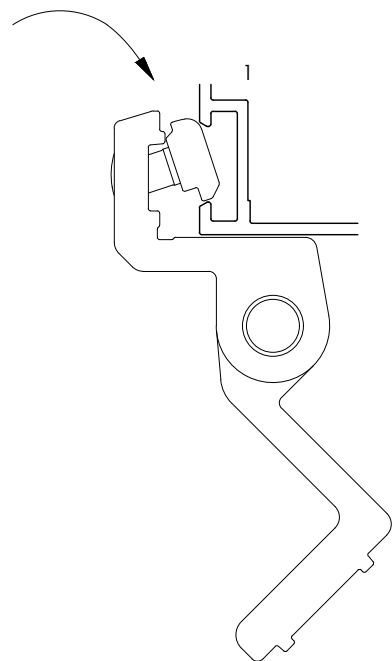

Part: A

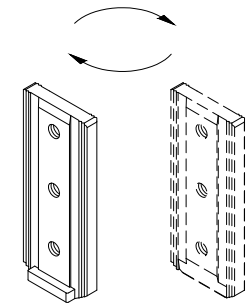
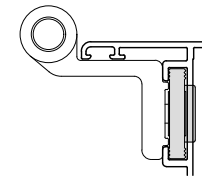
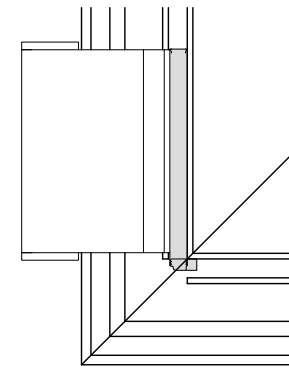

Per il montaggio di cerniere intermedie ruotare la contropiastra con il dentello verso l'esterno

For the assembling of intermediate hinges, rotate the counter-plate with tooth outwards

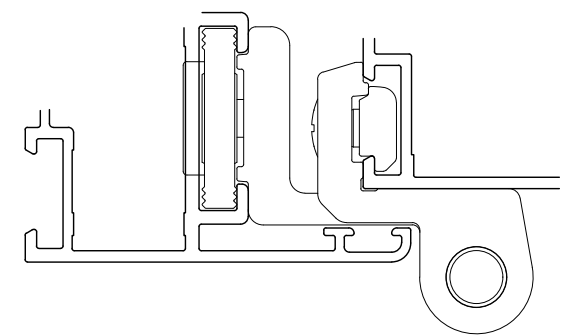
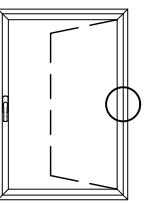
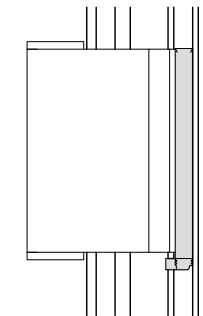

➤ MONTAGGIO CERNIERE NASCOSTE ANTA 100 kg
100 kg TURN-ONLY CONCEALED HINGES ASSEMBLING

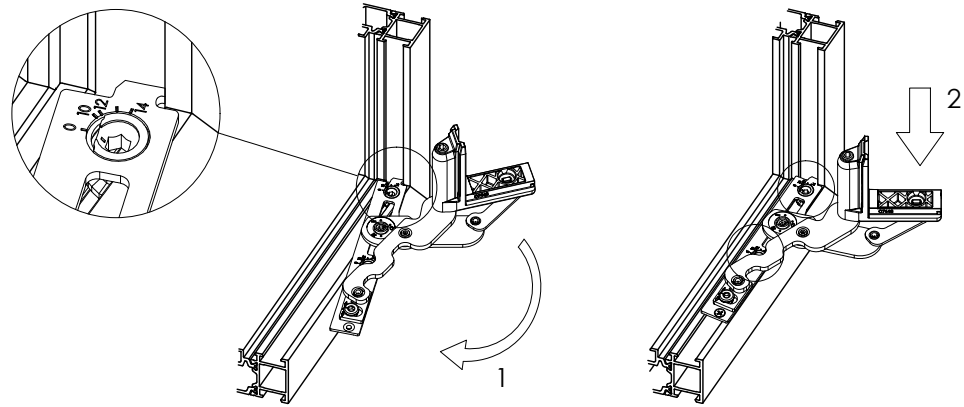
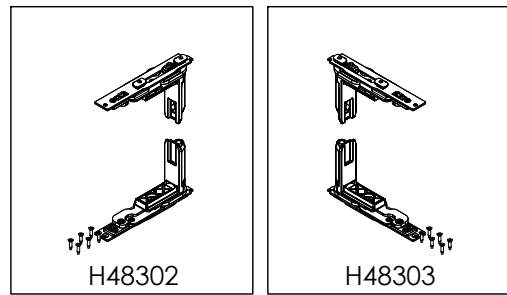

BLOCCAGGIO DELLE CAMMES
CAMMES LOCK

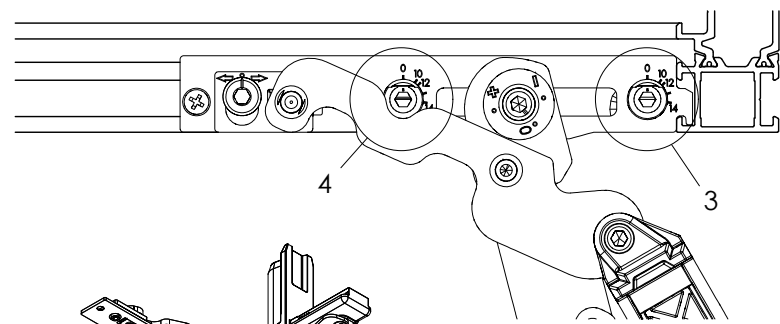

Cammes di fissaggio
Fixing cammes

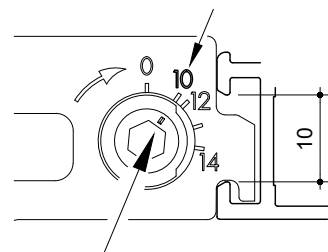

FISSAGGIO DELLE VITI
SCREW FIXING

Pre-forare Ø2.7 mm
Pre-drill Ø2.7 mm

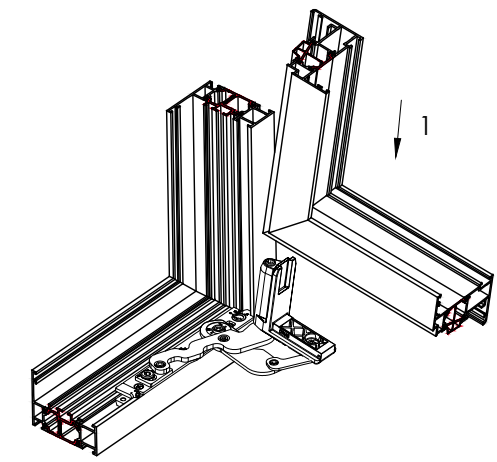
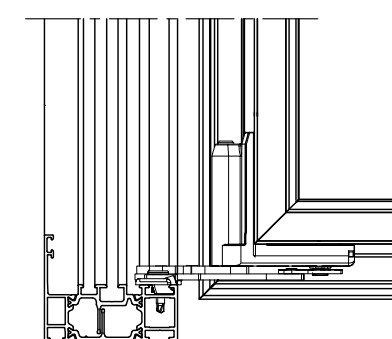
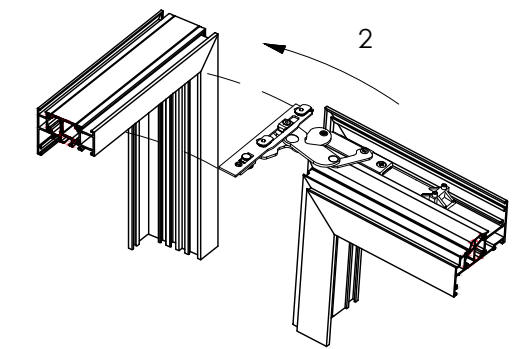
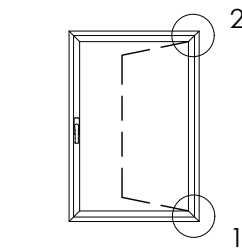
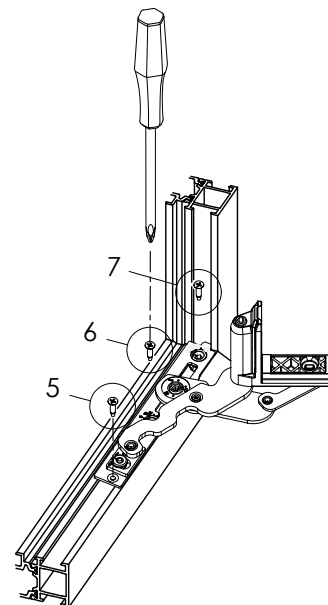
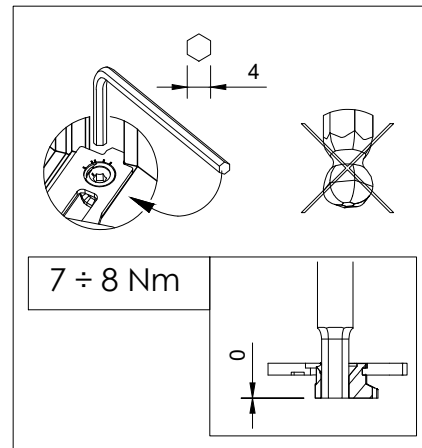
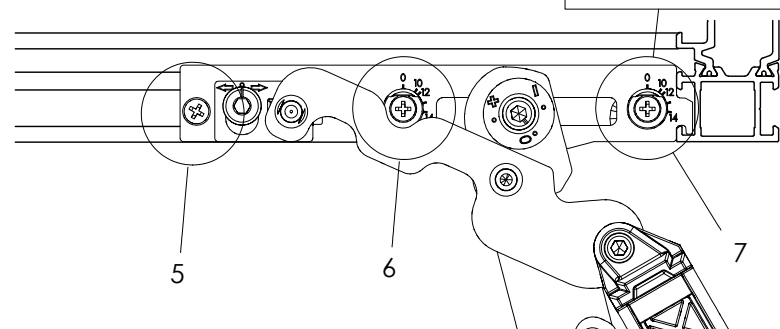

Regolazione in compressione
Compression adjustment

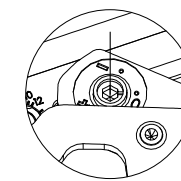

Regolazione laterale
Lateral adjustment

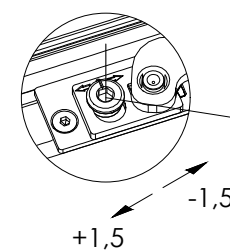

+2,5
-1
Regolazione in altezza
Height adjustment

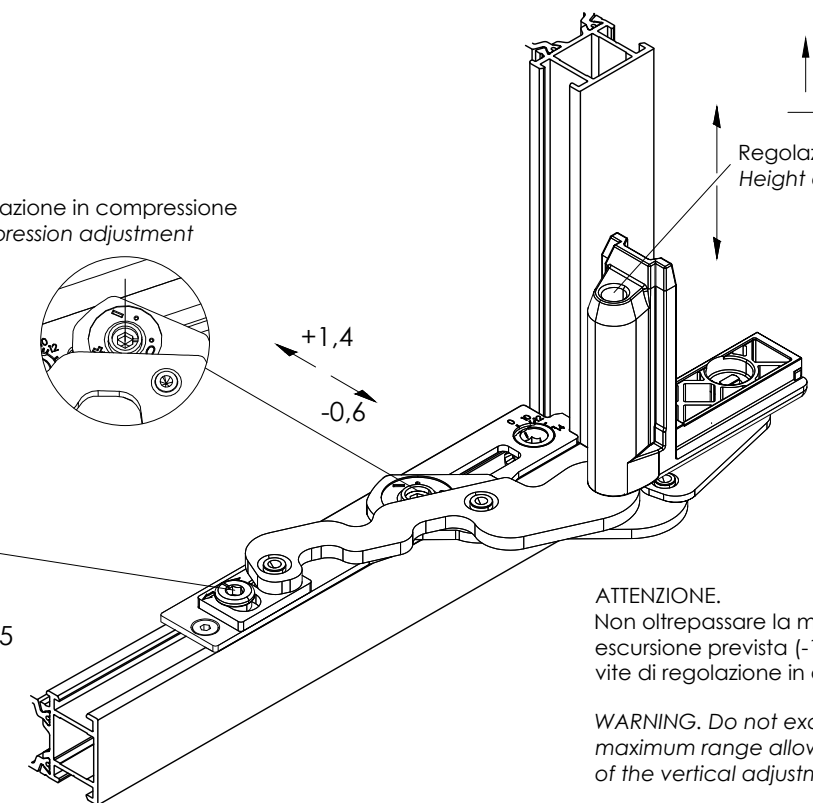

ATTENZIONE.
Non oltrepassare la massima escursione prevista (-1; +2,5 mm) per la vite di regolazione in altezza.

WARNING. Do not exceed the maximum range allowed (-1; +2.5 mm) of the vertical adjustment screw.

➤ MONTAGGIO CERNIERE NASCOSTE ANTA 150 kg
 150 kg TURN-ONLY CONCEALED HINGES ASSEMBLING

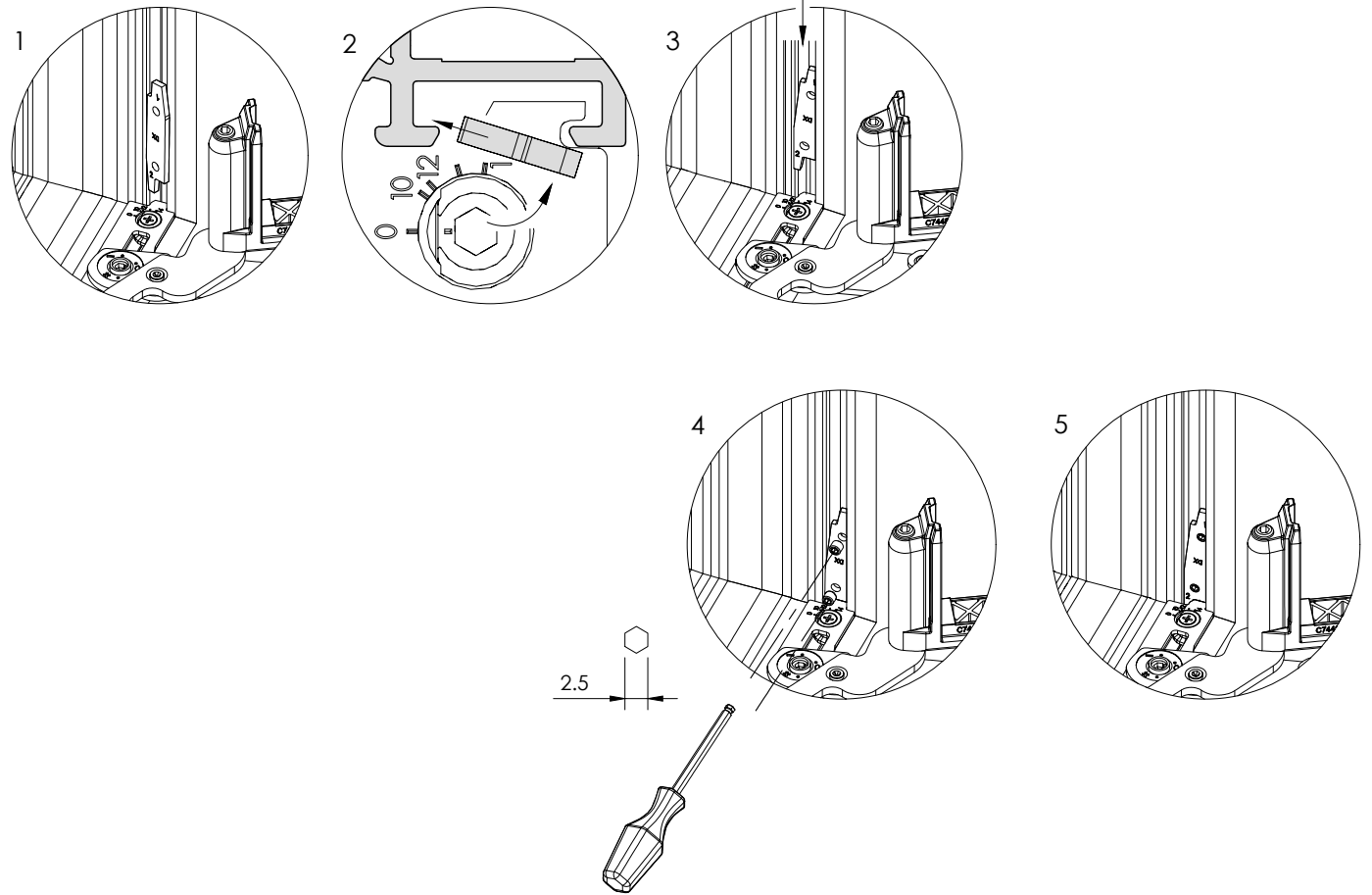
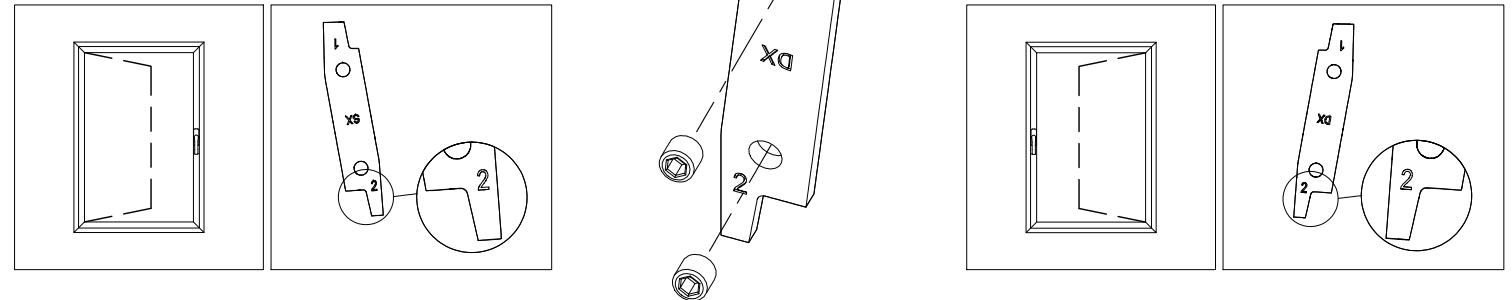
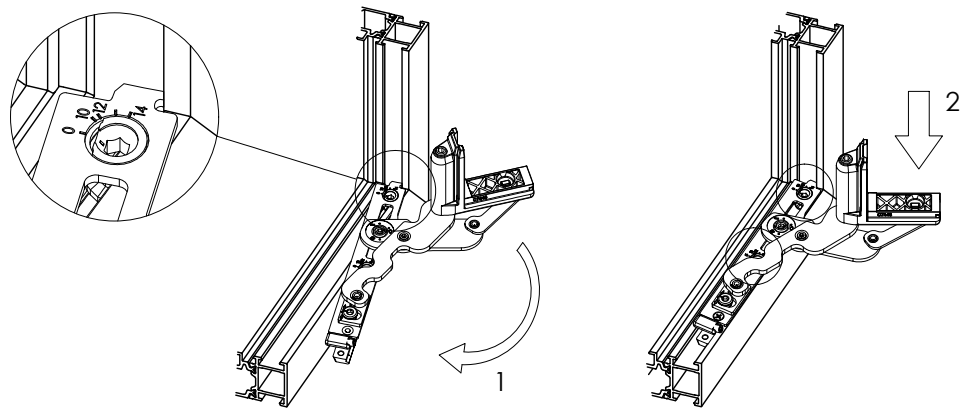
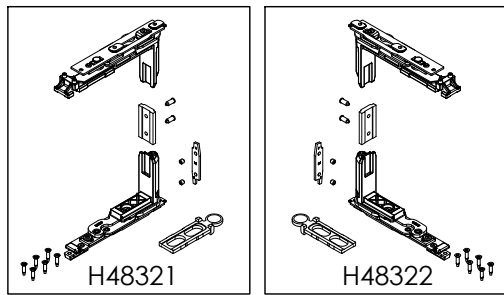
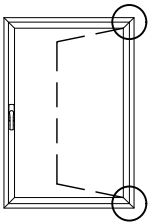

BLOCCAGGIO DELLE CAMMES
 CAMMES LOCK

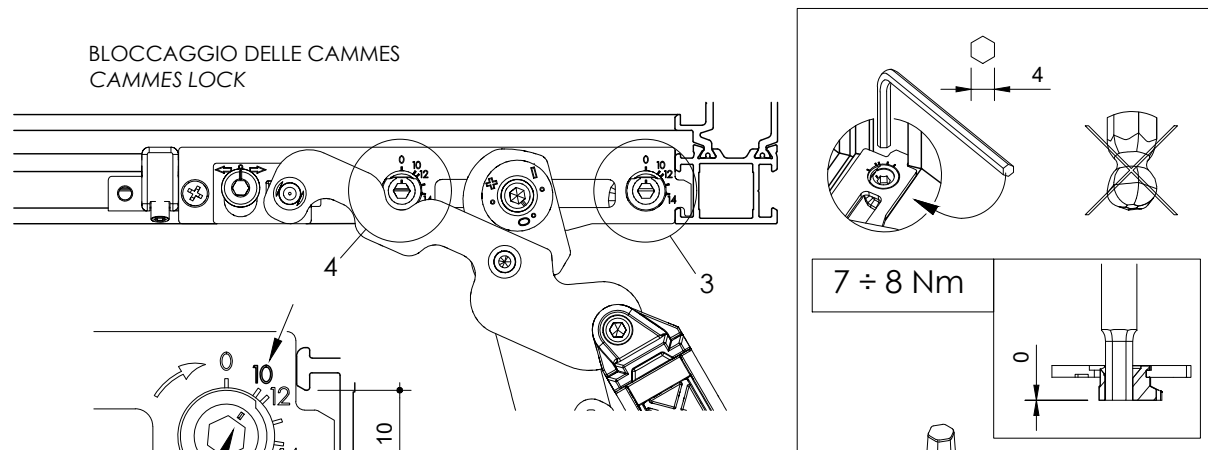

FISSAGGIO DELLE VITI
 SCREW FIXING

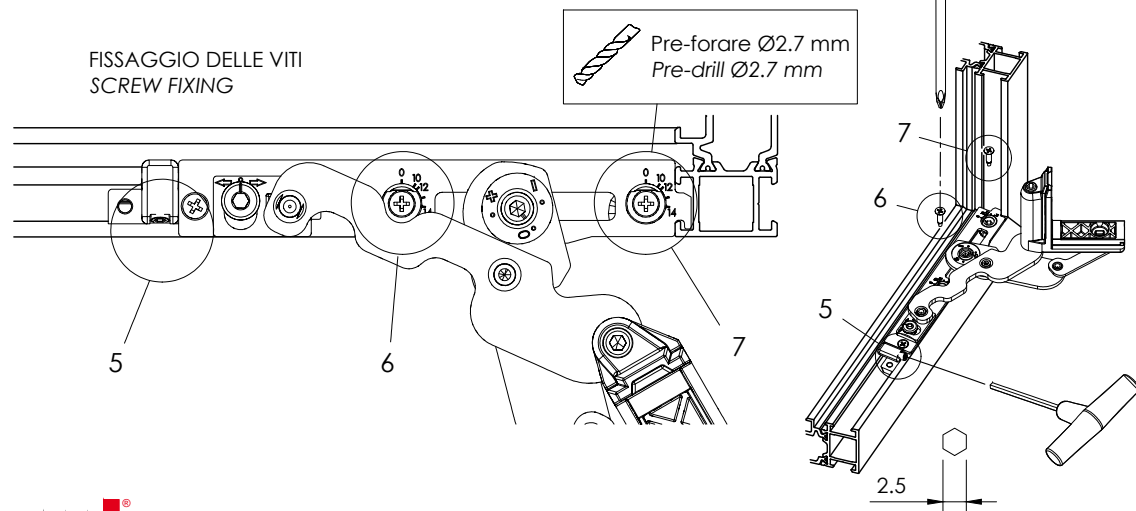

➤ **MONTAGGIO CERNIERE NASCOSTE ANTA 150 kg**
150 kg TURN-ONLY CONCEALED HINGES ASSEMBLING

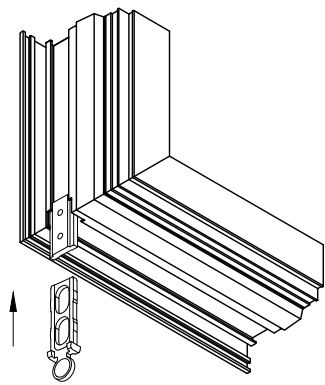

Utilizzare la dima per il posizionamento delle cerniere
 Use the template for hinge positioning

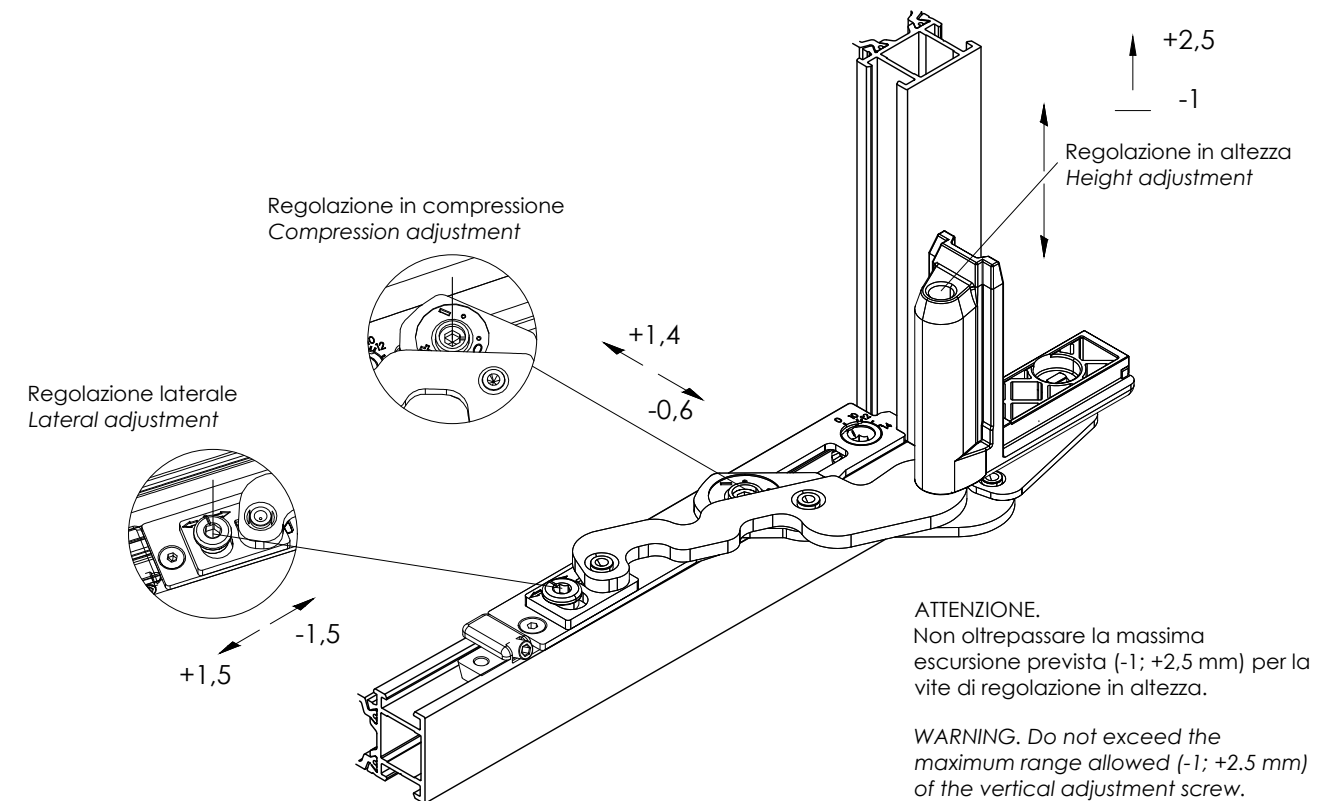
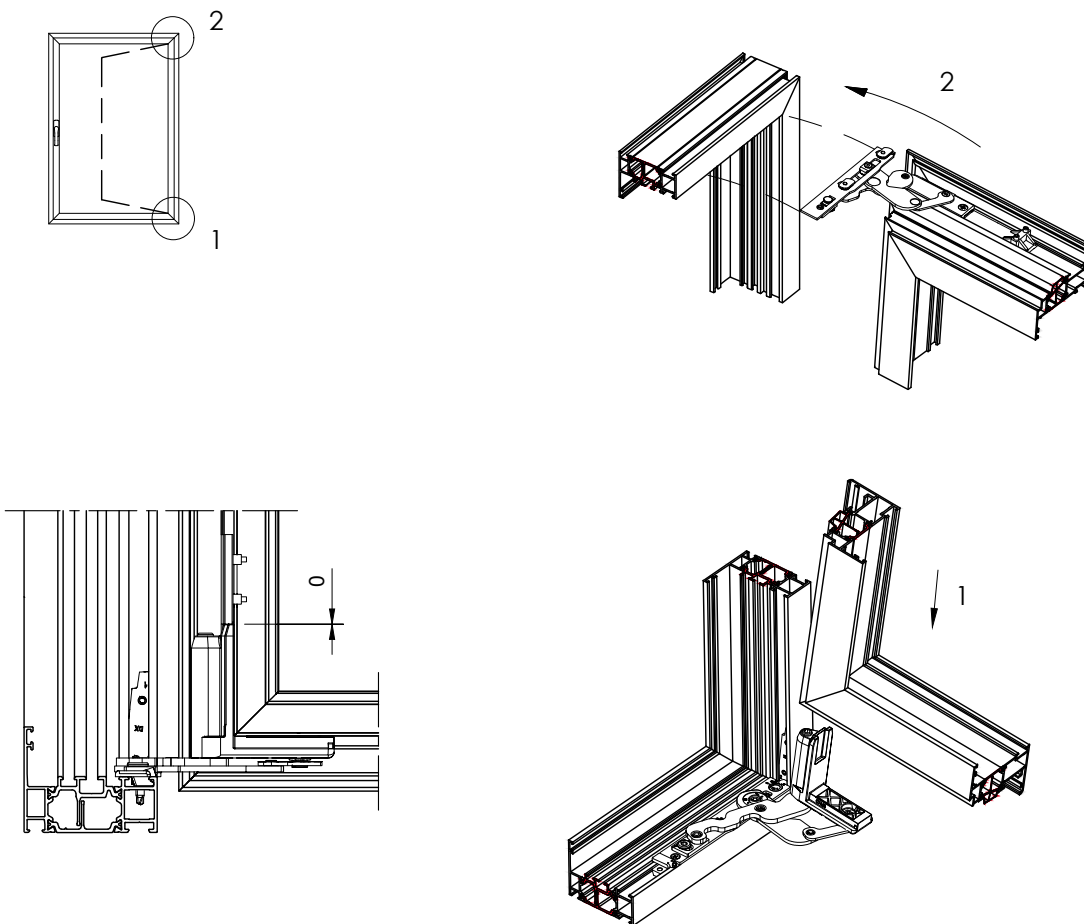
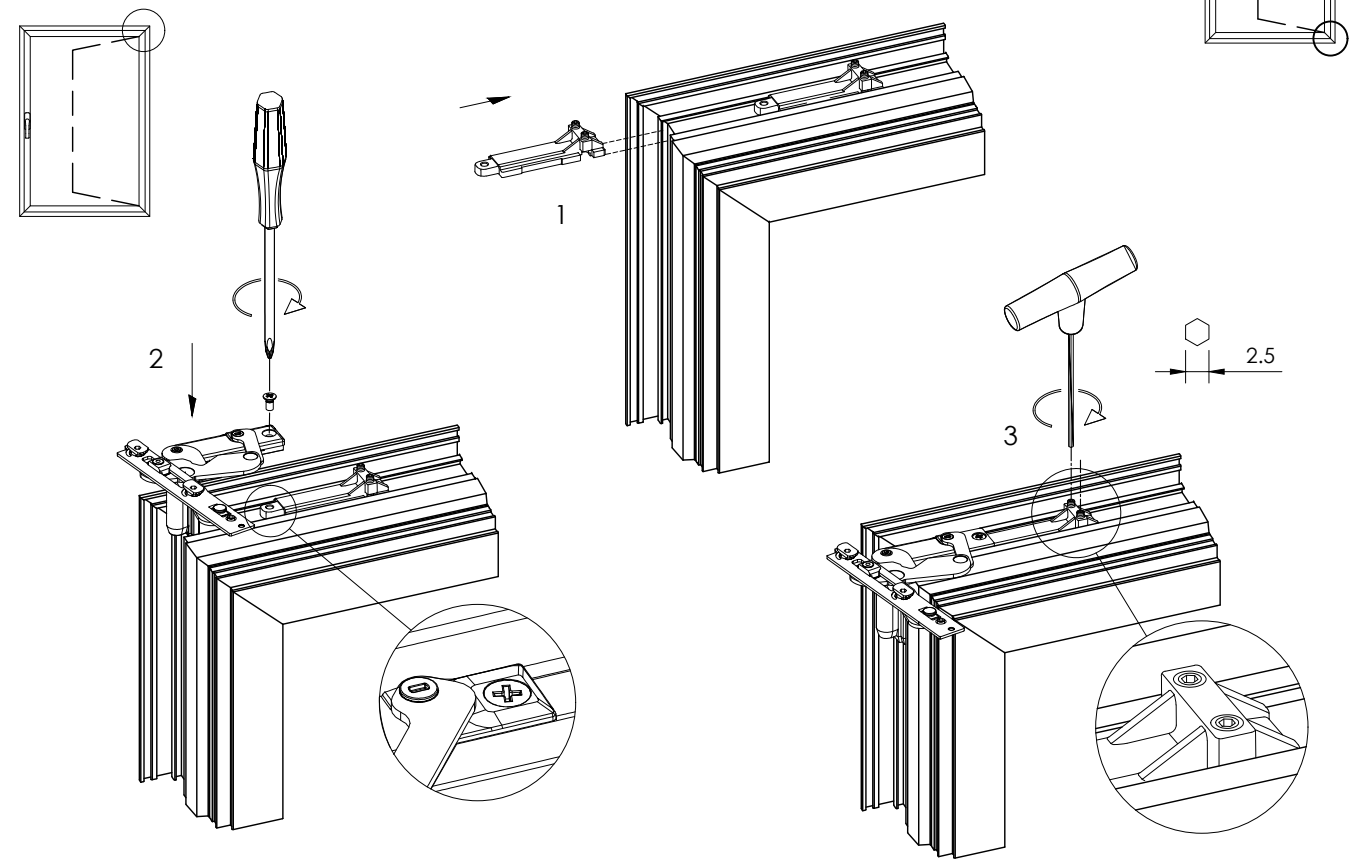
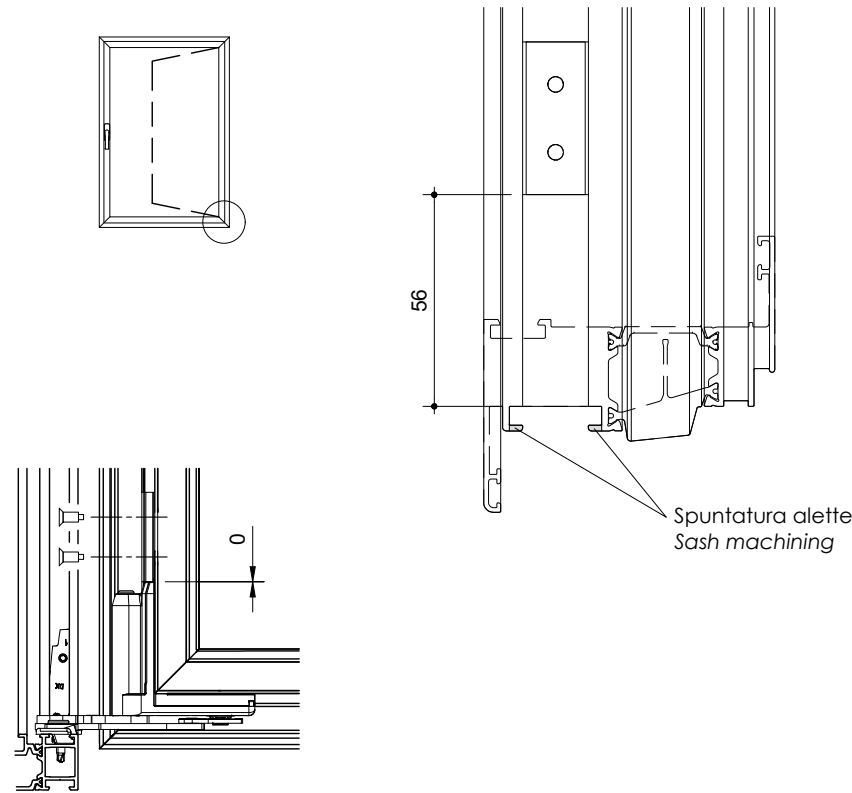

ATTENZIONE.
 Non oltrepassare la massima escursione prevista (-1; +2,5 mm) per la vite di regolazione in altezza.

WARNING. Do not exceed the maximum range allowed (-1; +2.5 mm) of the vertical adjustment screw.

▶ MONTAGGIO CERNIERE A PETTINE TERZA ANTA
 THREE-PART HINGES FOR THIRD SASH ASSEMBLING

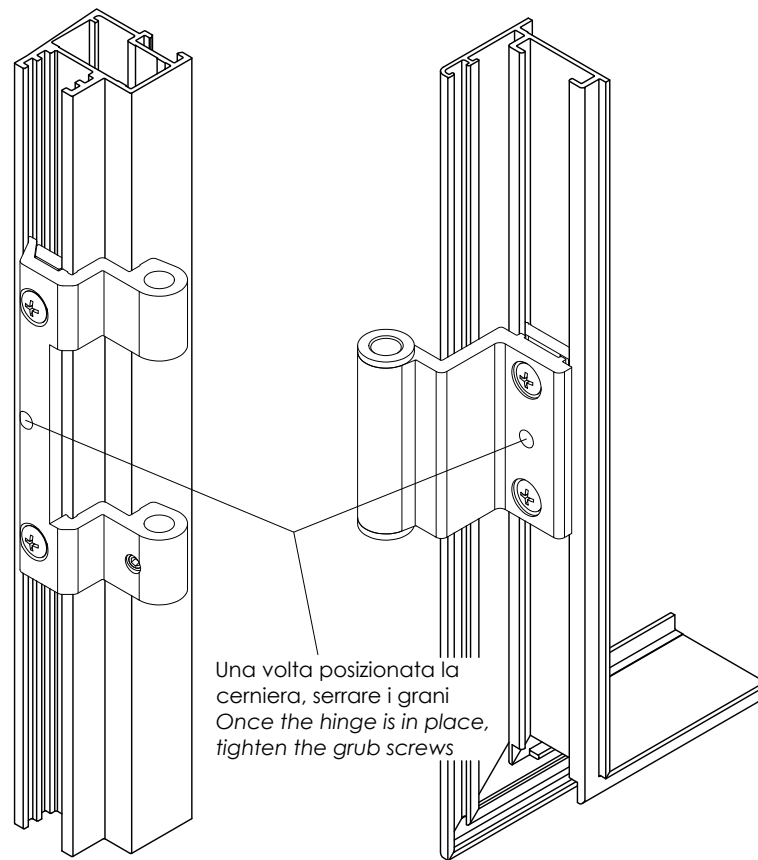
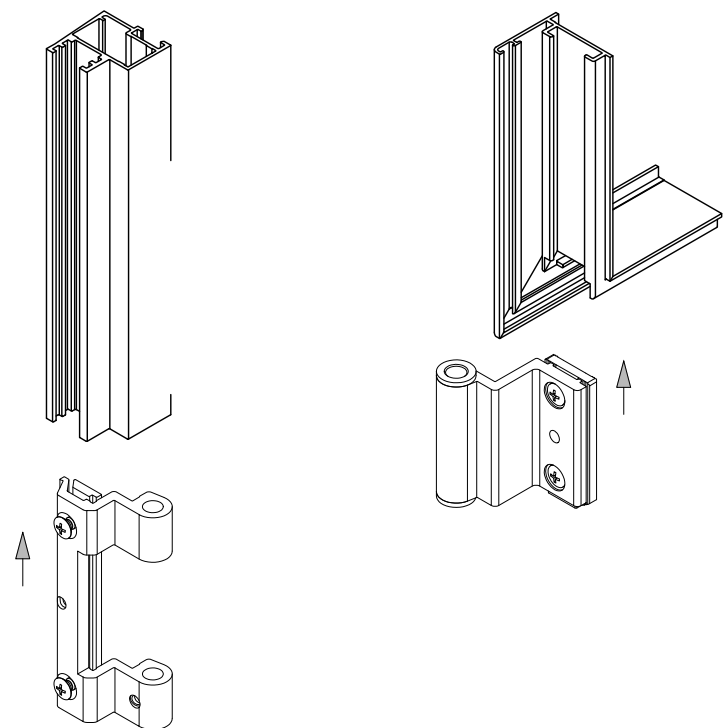
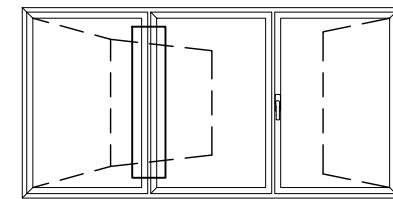
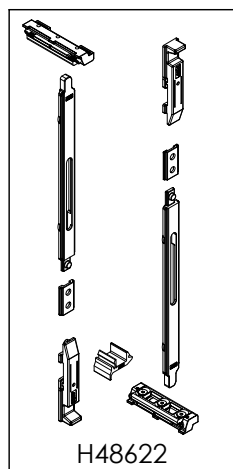
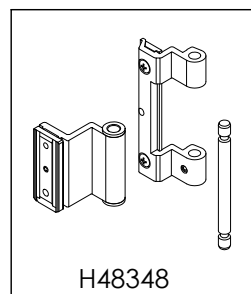

Una volta accoppiata la cerniera, inserire il perno e fissarlo con il grano

Once the hinge is coupled, insert the pin and secure it with the grub screw

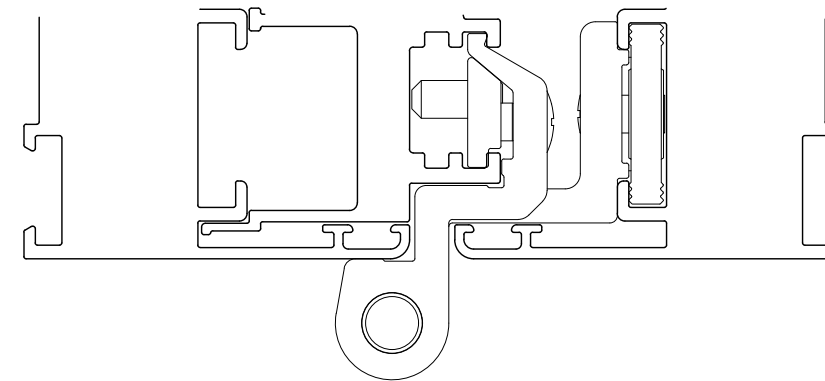
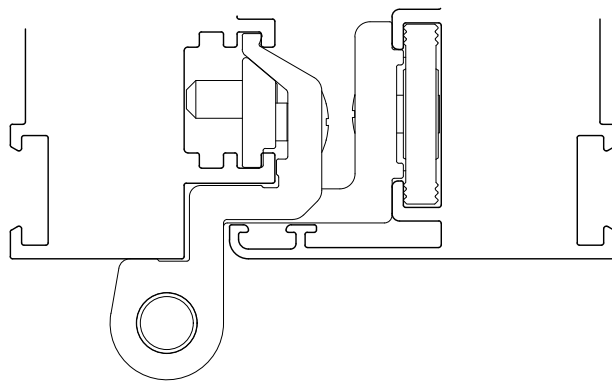
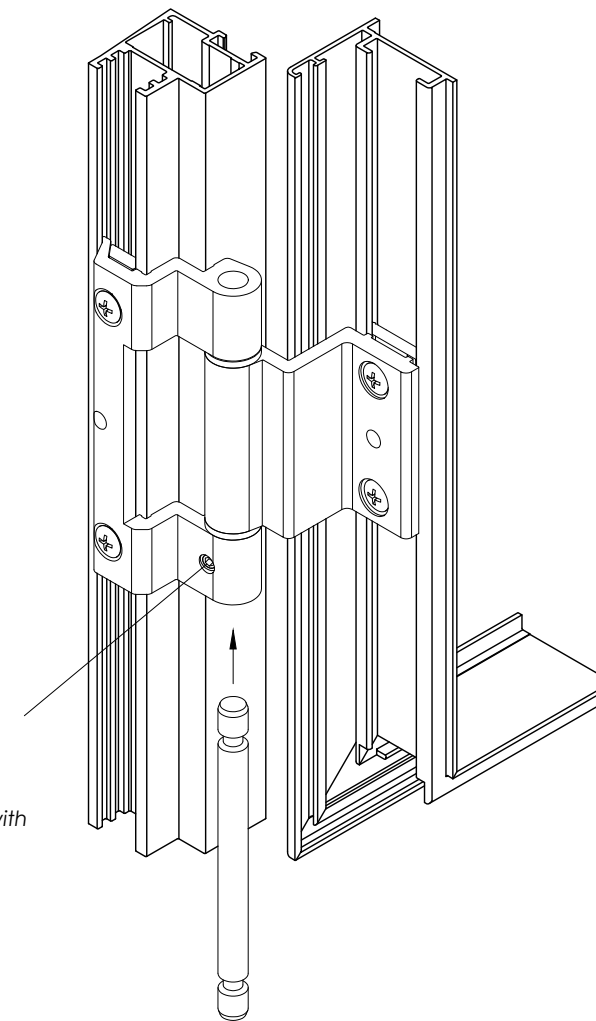

➤ MONTAGGIO KIT FALSA CERNIERA
 FALSE HINGE KIT ASSEMBLING

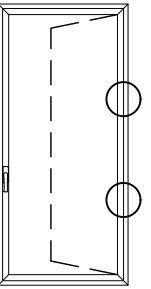
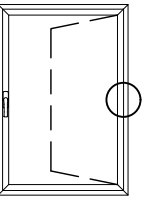
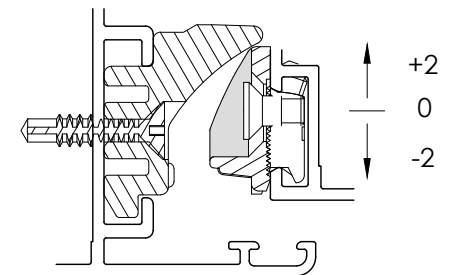
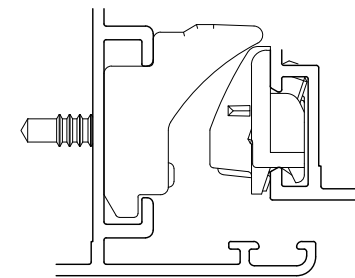
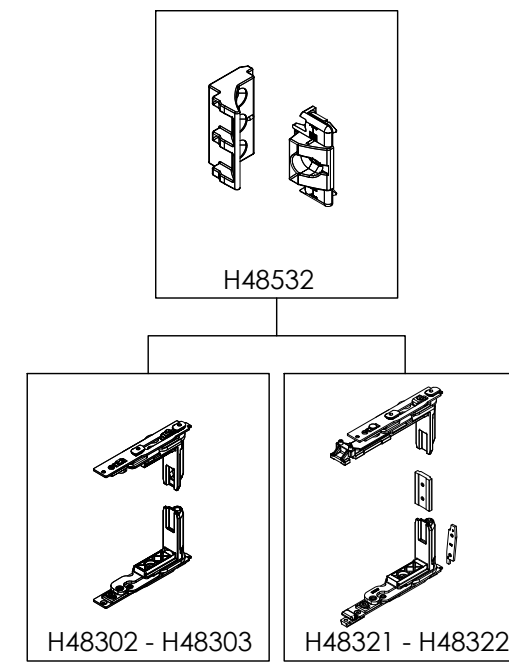
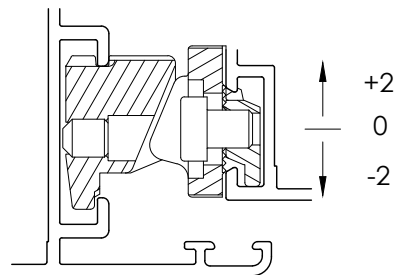
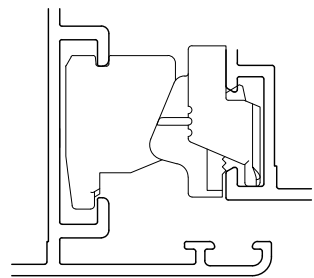
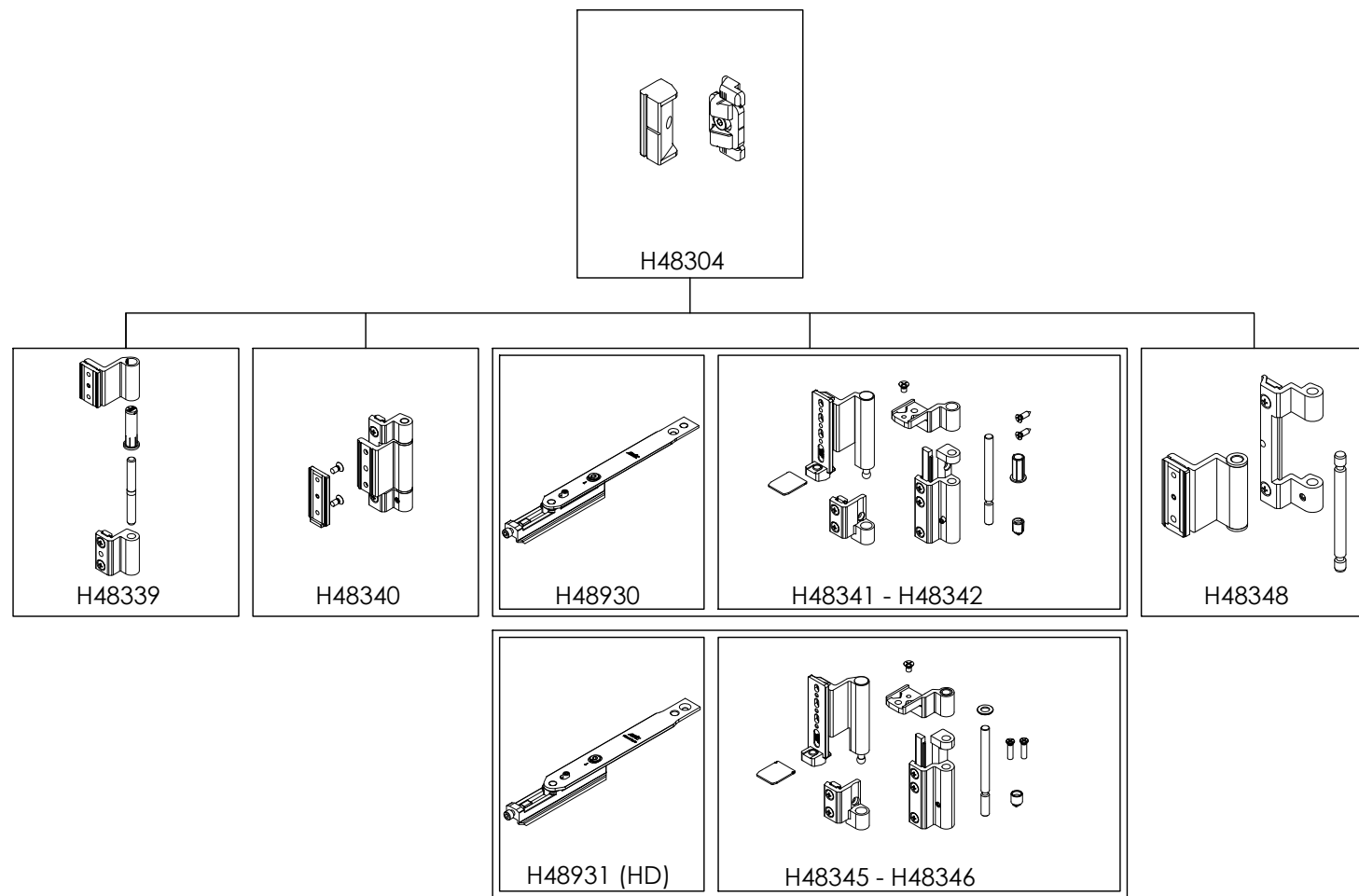

MONTAGGIO BRACCIO FALSA FORBICE
TURN-ONLY ARM ASSEMBLING

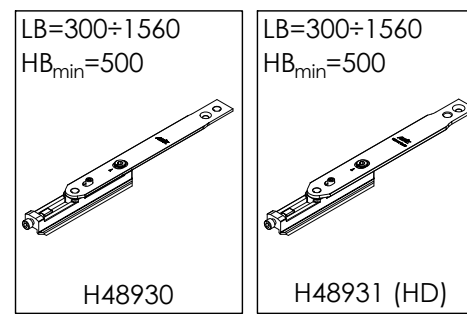
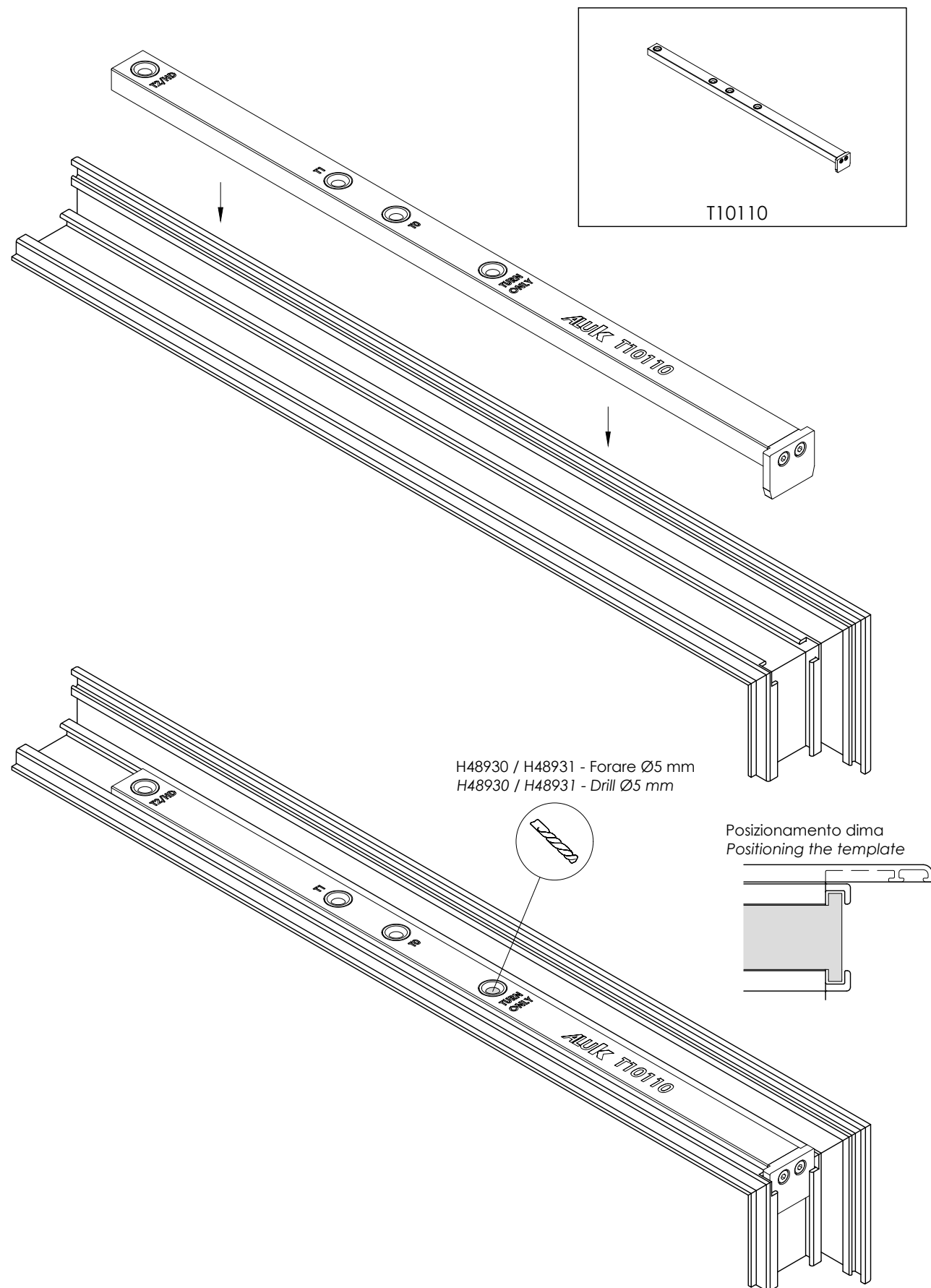

La semicerniera superiore deve essere fissata al braccio ESCLUSIVAMENTE con la vite speciale con bloccafilletto
Upper hinge must be MANDATORY fixed on top arm by special screw with thread stopper

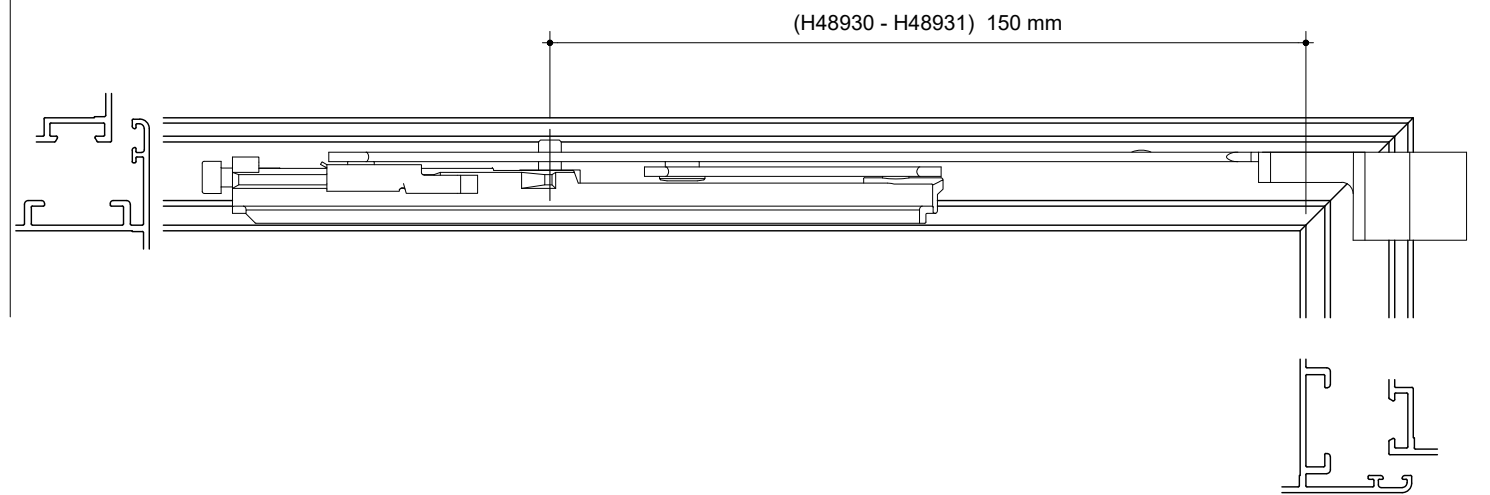
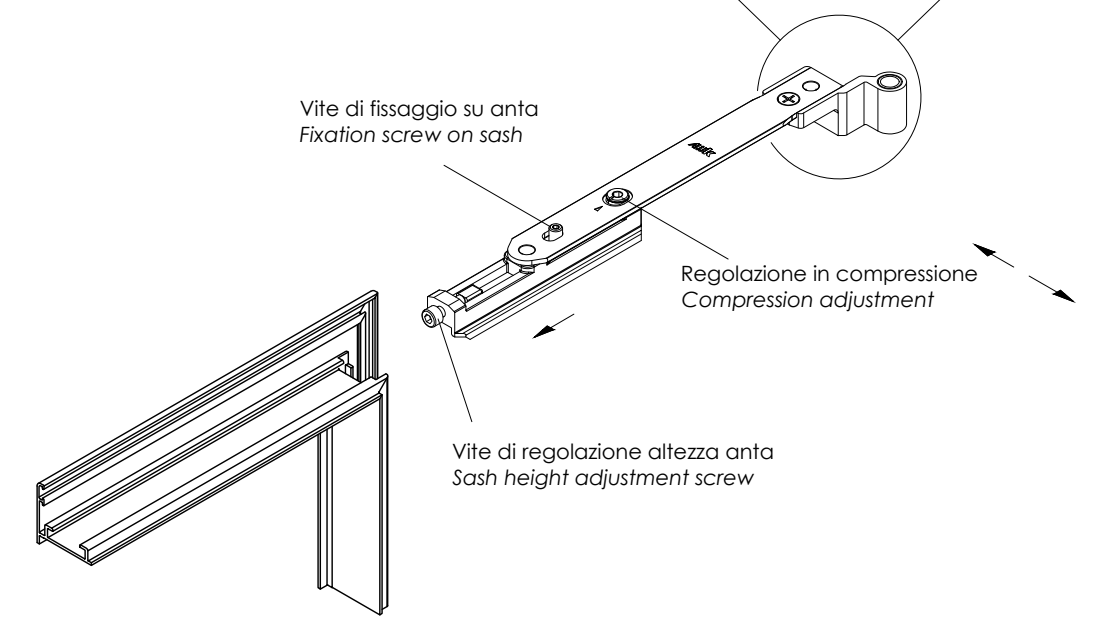
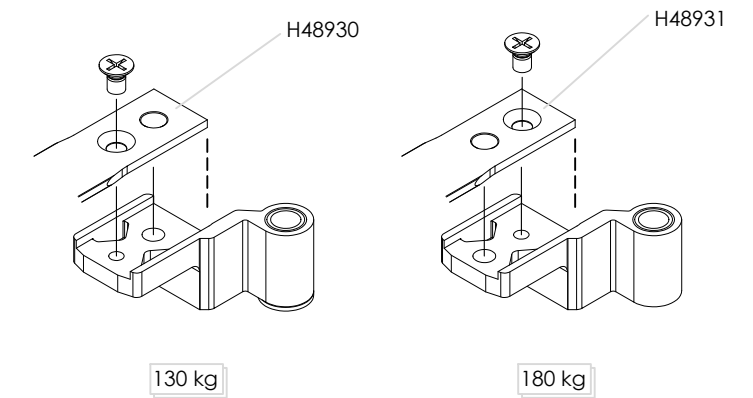

➤ MONTAGGIO BRACCIO FALSA FORBICE CON CHIUSURE LATO CERNIERA
 TURN-ONLY ARM ASSEMBLING WITH ADDITIONAL LOCKINGS

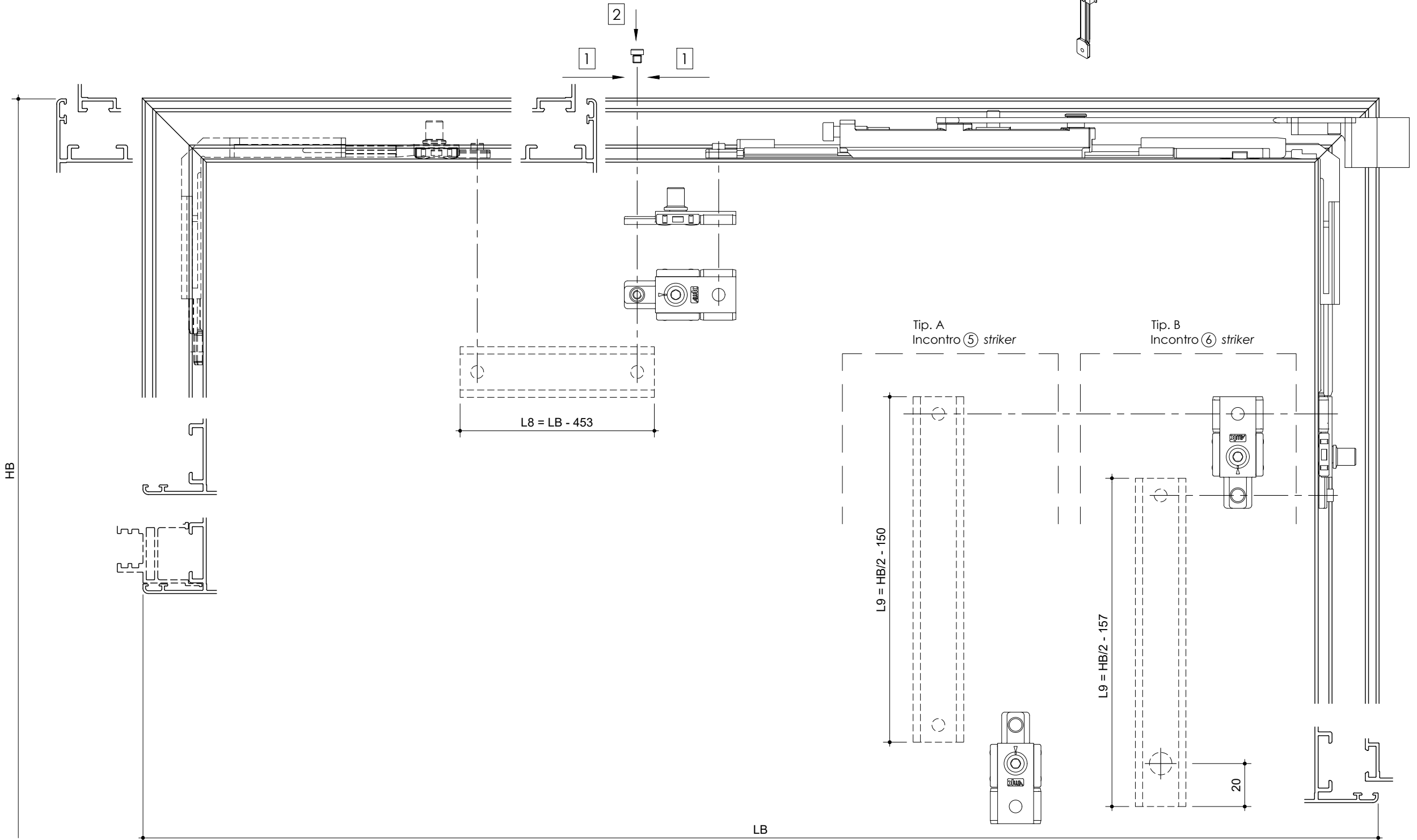
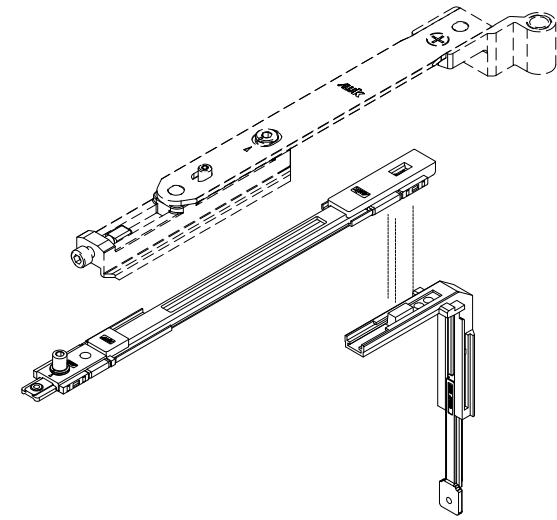
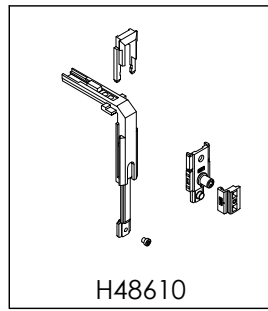
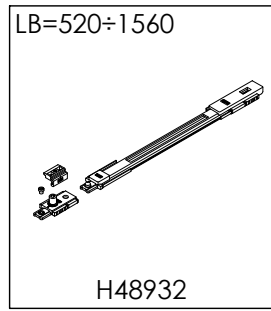
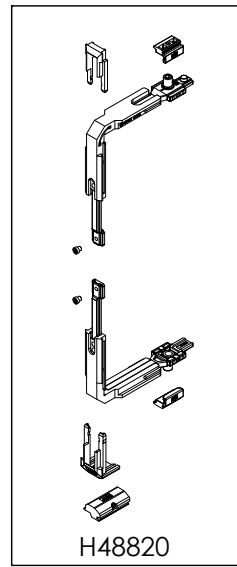
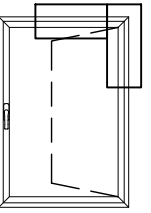

MONTAGGIO CHIUSURA PER ANTA CON CREMONESE O CREMONESE INCASSATA
TURN-ONLY SASH LOCKING WITH CREMONE OR GEARBOX

C67K	C77K	C77K-CS	C67K-M
●	●	●	●
C45K-NI		C55K-NI	
●		●	

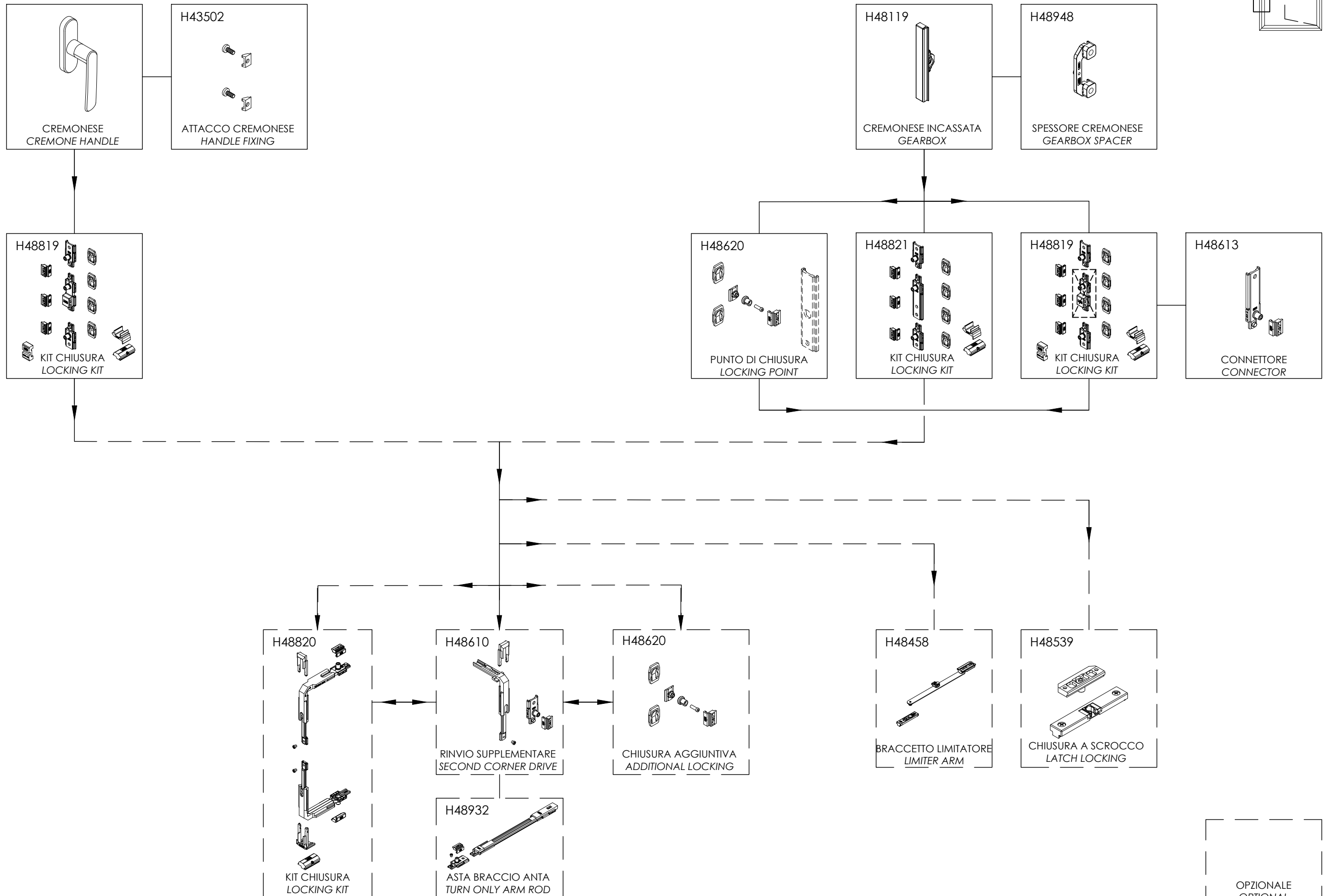
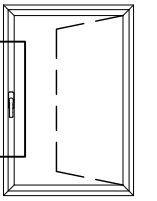

► **MONTAGGIO CHIUSURA PER ANTA CON CREMONESE O CREMONESE INCASSATA**
TURN-ONLY SASH LOCKING WITH CREMONE OR GEARBOX

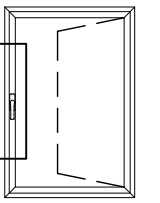
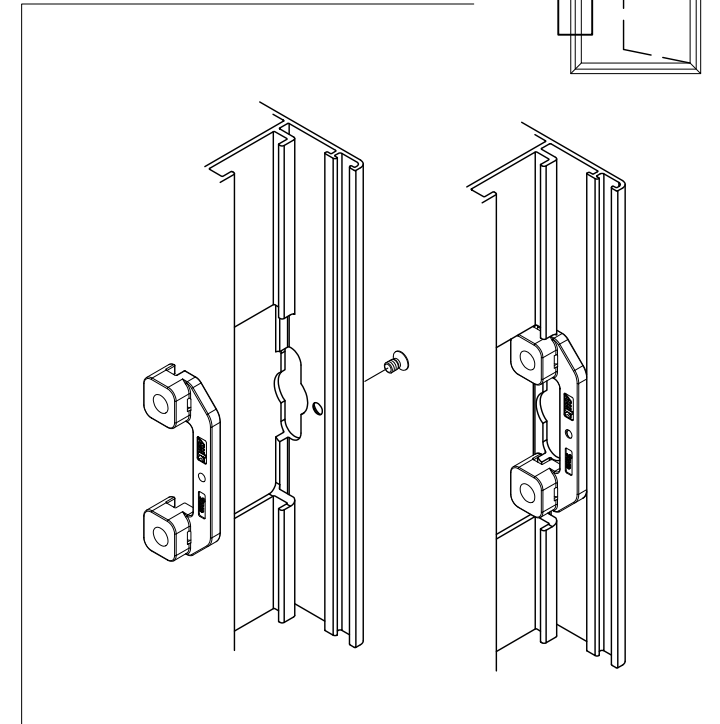
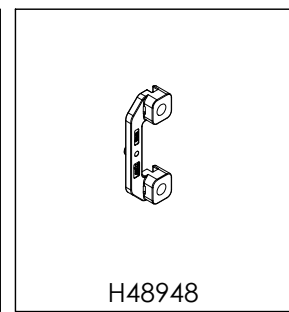
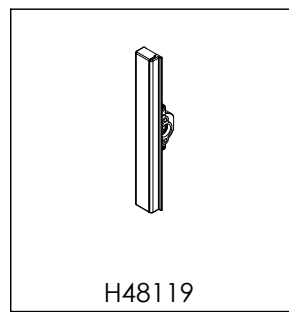
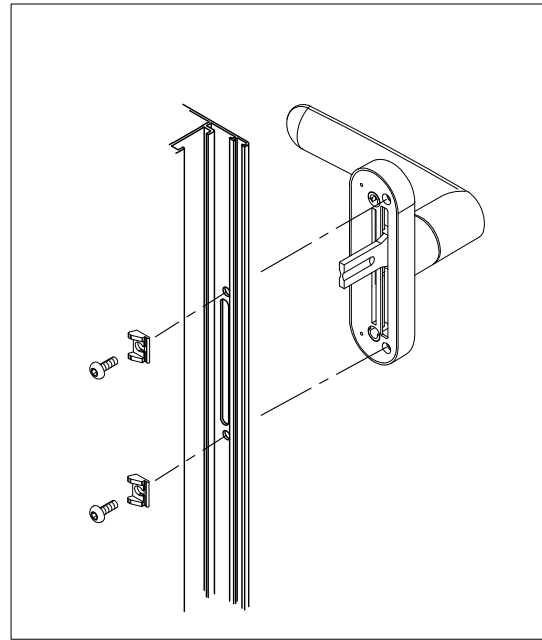
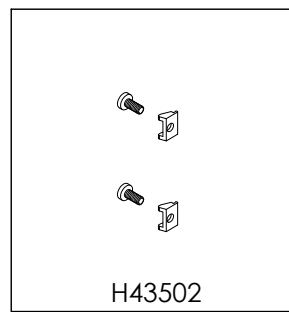

Invertire la forcella per passare da cremonese dx a sx

Reverse the fork to switch from right hand to left hand cremone

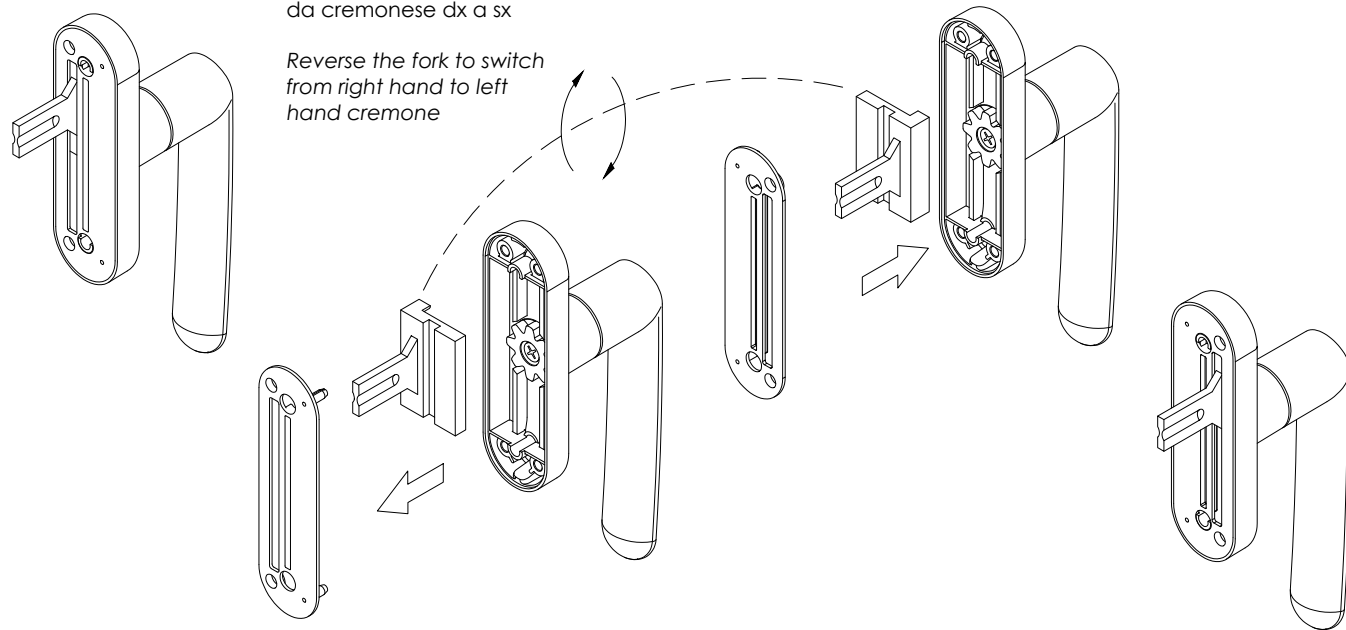

Posizionamento del blocco a 90° per cremonese
Positioning of 90° lock for cremone handle

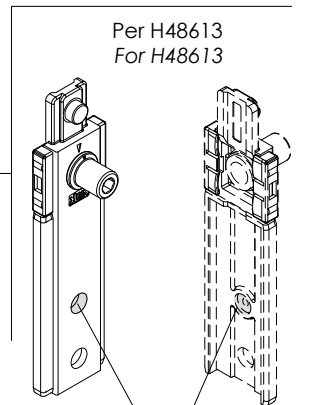
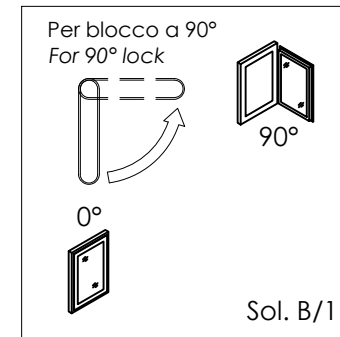
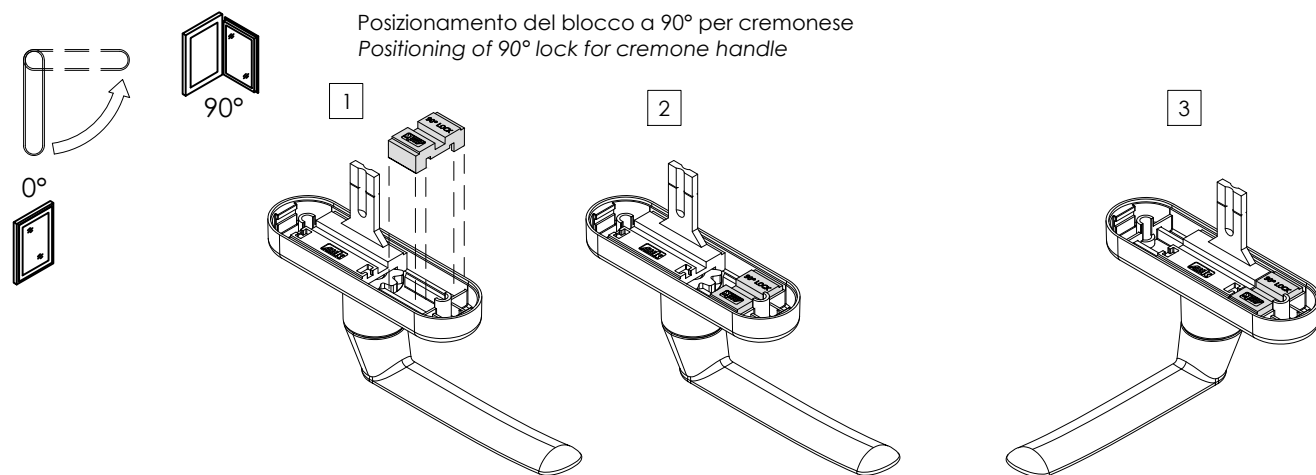

Forare Ø6 mm
Drill Ø6 mm

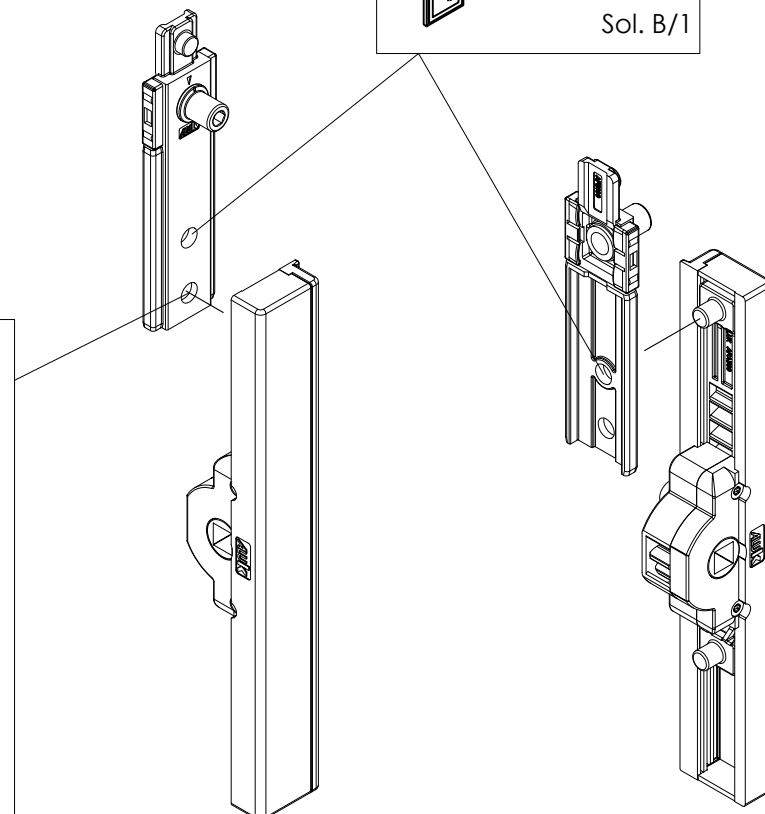
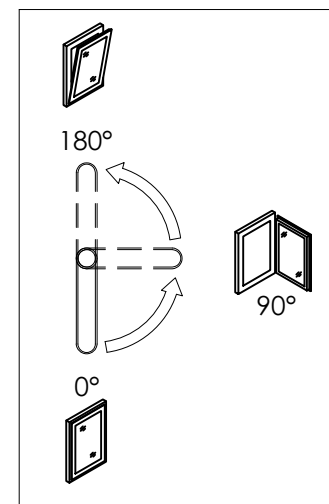

► MONTAGGIO CHIUSURA UN'ANTA BATTENTE
TURN-ONLY SASH LOCKINGS ASSEMBLING

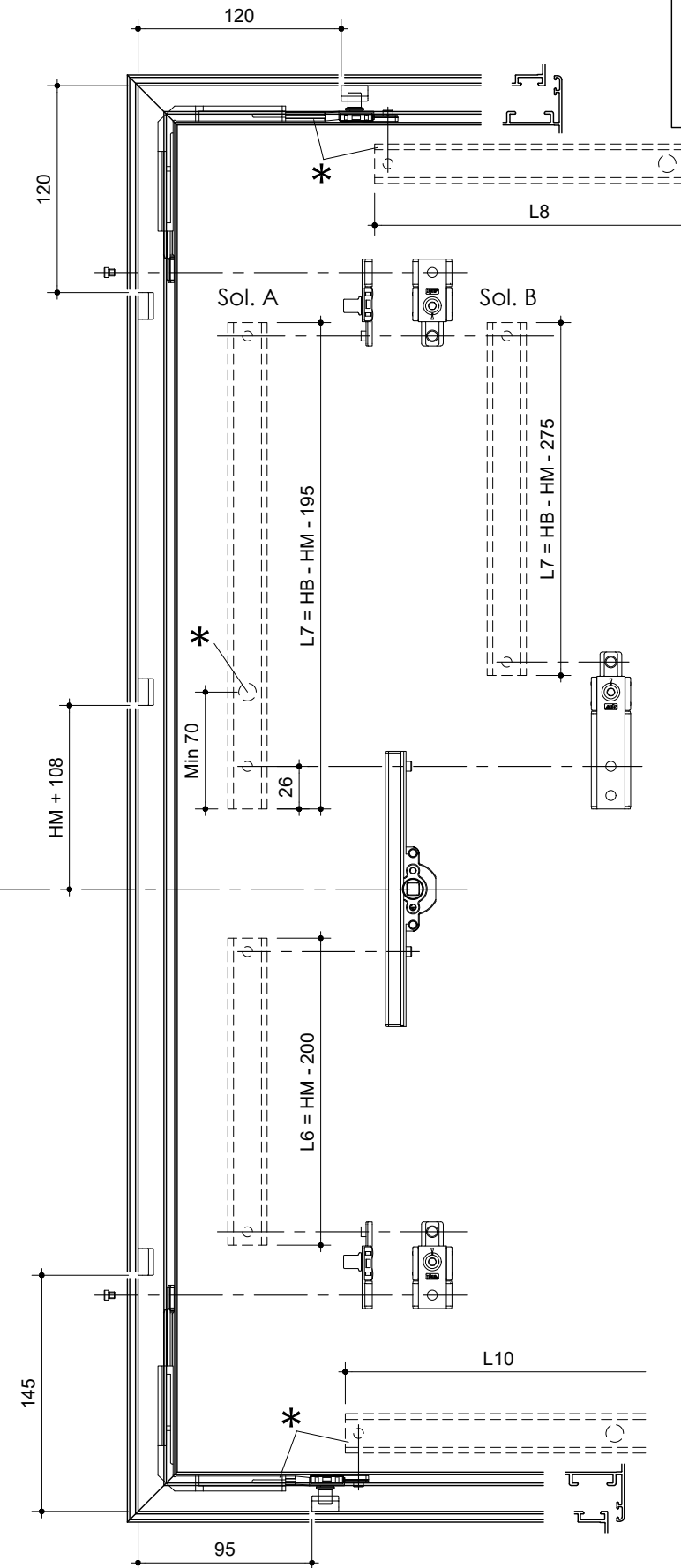
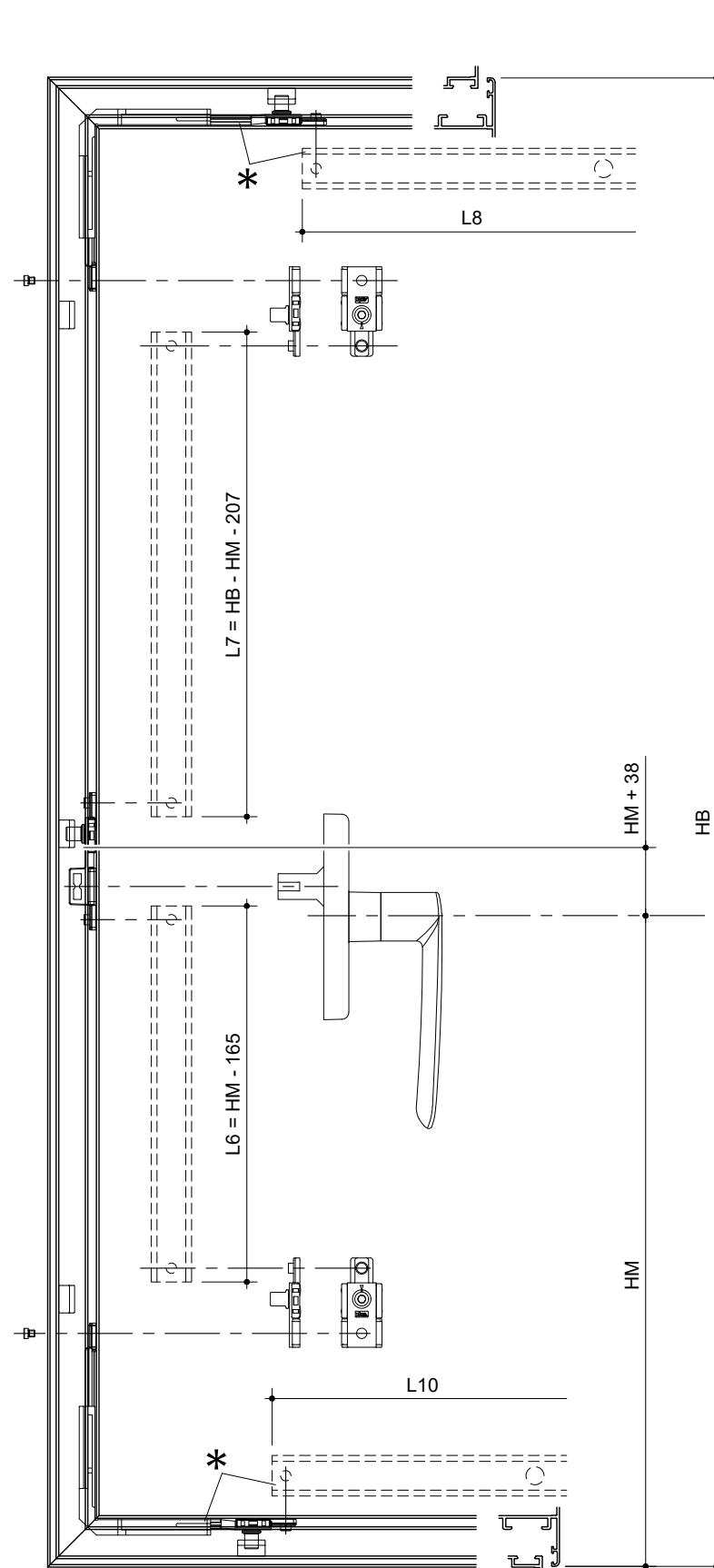
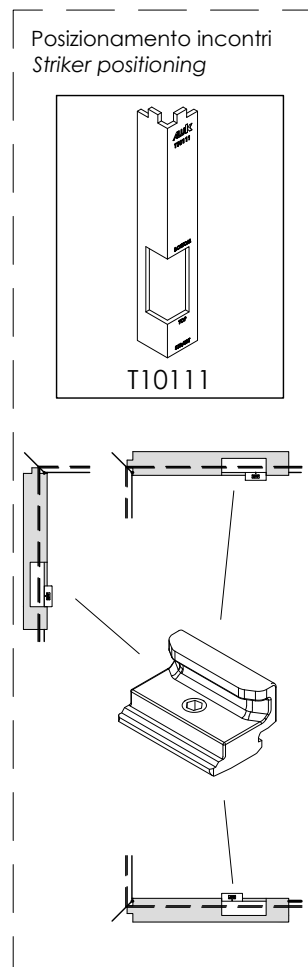
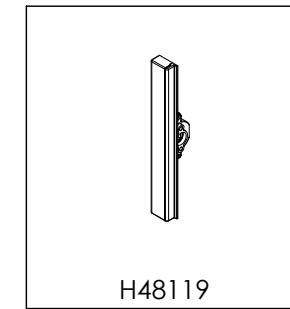
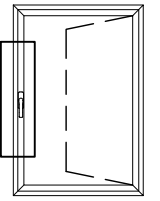

-	HM min [mm]
Cremonese	265
H48119	300

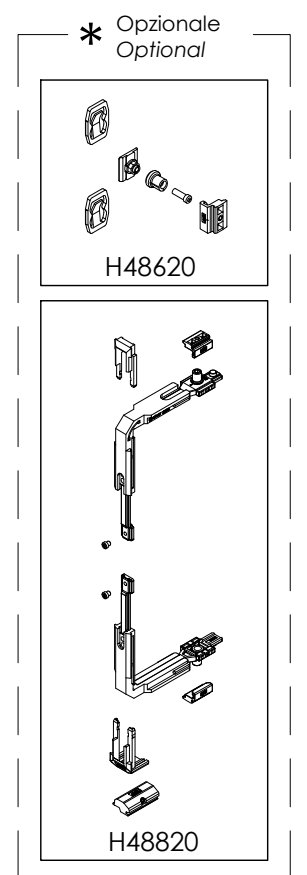

MONTAGGIO CHIUSURA SECONDA ANTA BATTENTE TURN-ONLY SLAVE SASH LOCKING ASSEMBLING

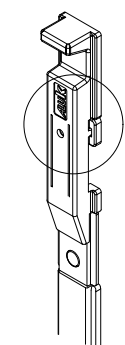
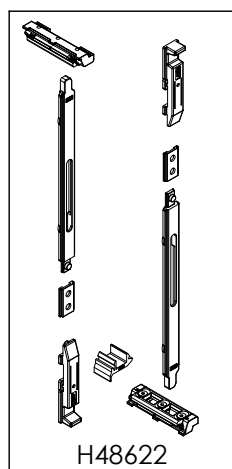
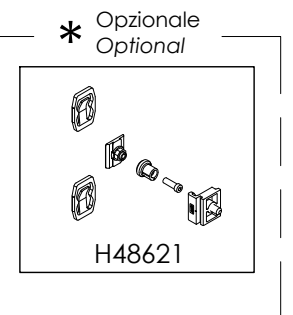
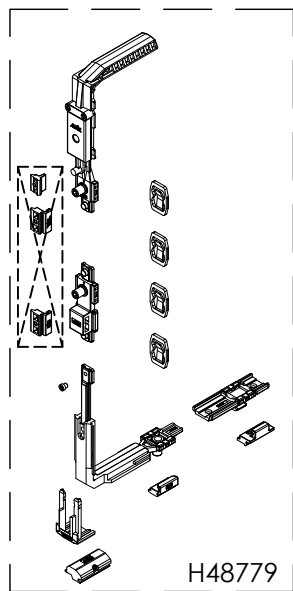
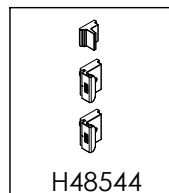
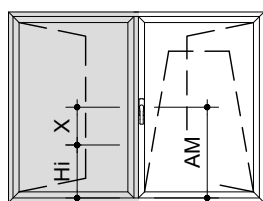
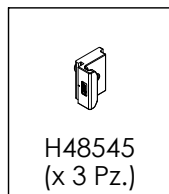
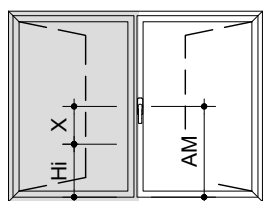
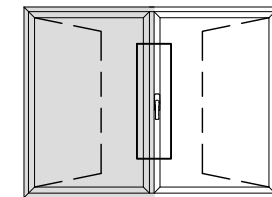

Montato il catenaccio per la messa in fase bisogna far saltare il blocco sul catenacciolo
Once the locking bolt is installed brake the bridge for phase adjustment

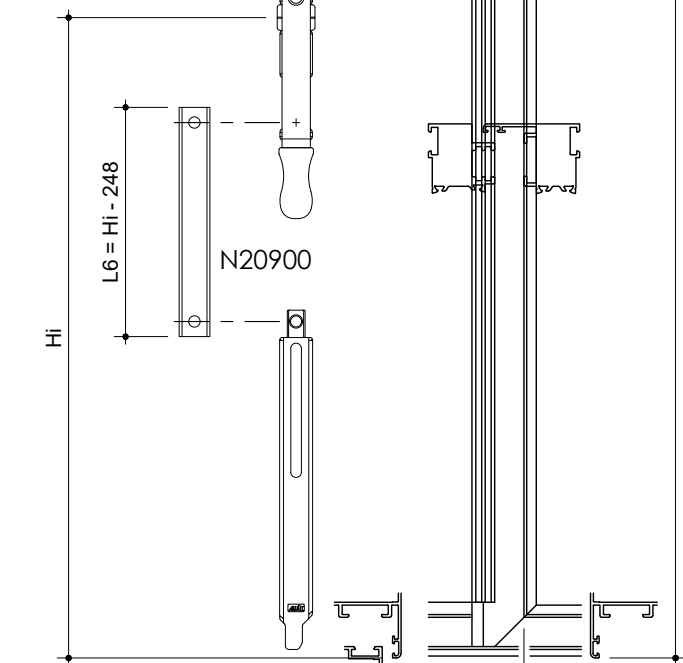
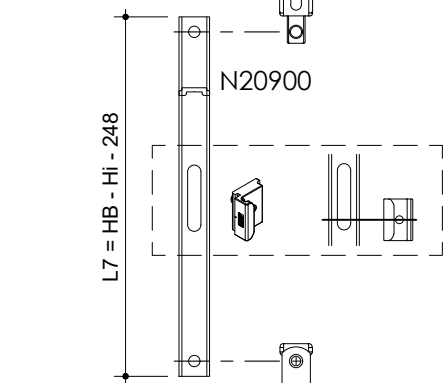
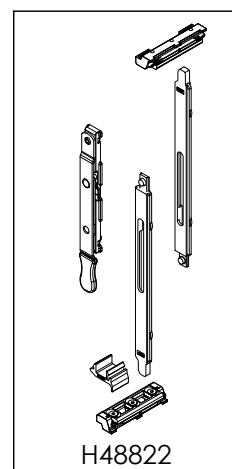
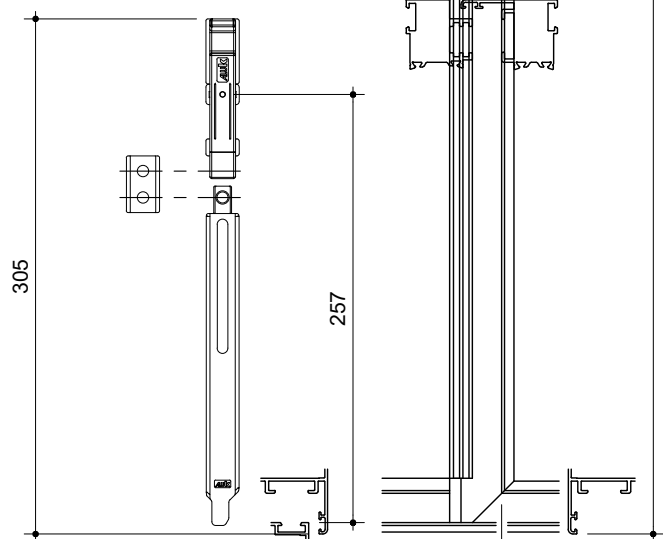

L'incontro nella cava centrale va infilato

The strikers in the central groove must be threaded

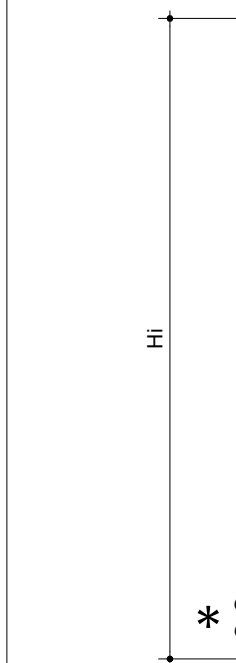
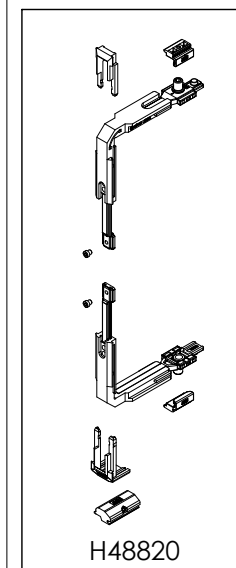
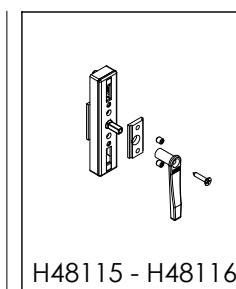
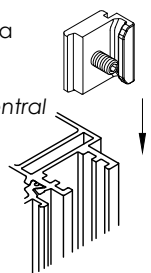

* Opzionale
Optional

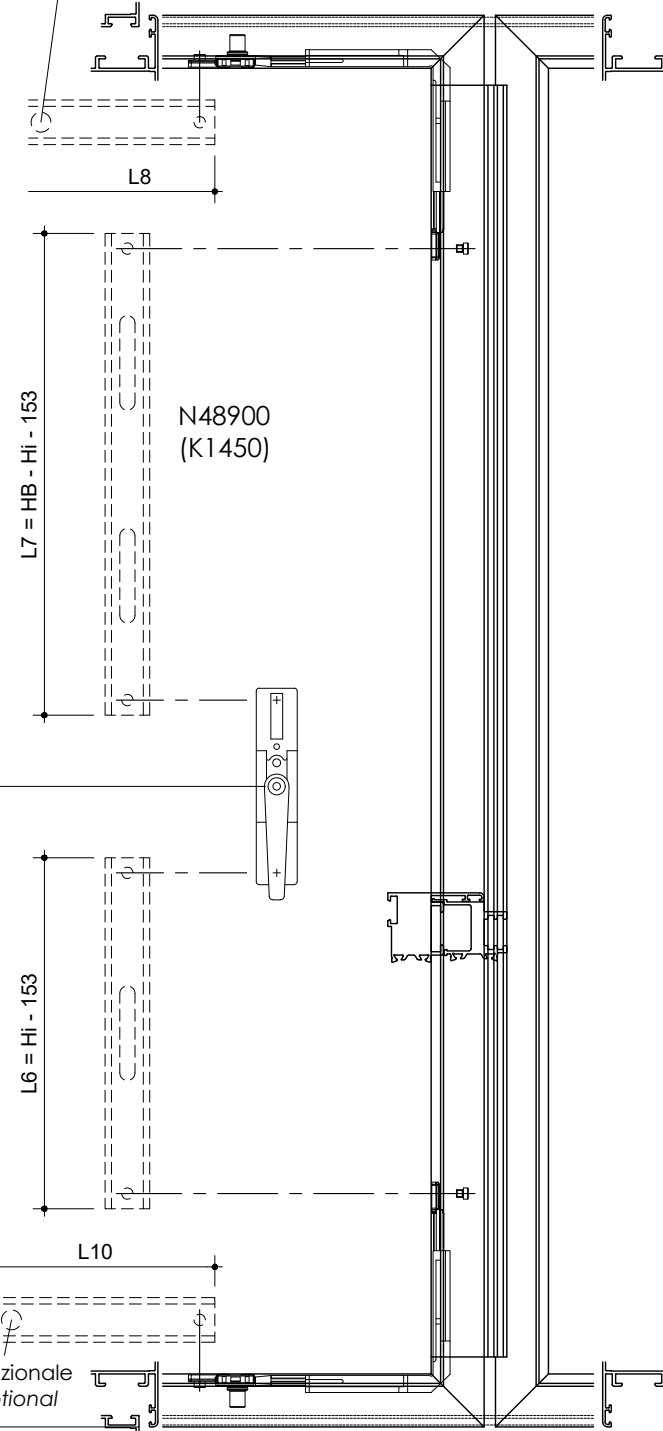

* Opzionale
Optional

-	Hi min [mm]
H48822	350
H48115 - H48116	255

X [min.]				
-	Cremonese	H48111	H48119	
H48822	170	250	170	
H48115 - H48116	170	210	170	
H48115 - H48116 [HB > 2200mm]	-	-	250	

MONTAGGIO KIT CHIUSURA A SCROCCO E BRACCETTO LIMITATORE
ASSEMBLY OF LATCH LOCKING KIT AND LIMITER ARM

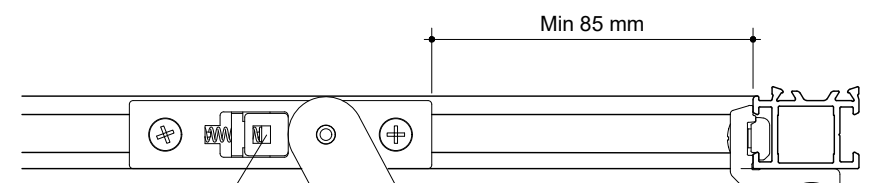
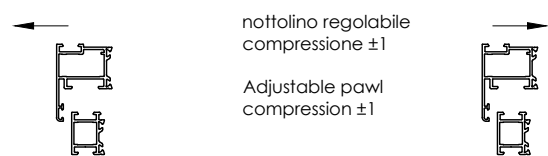
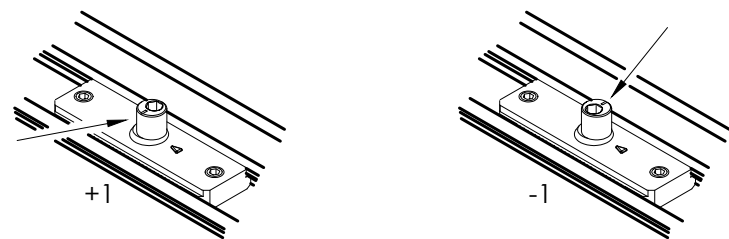
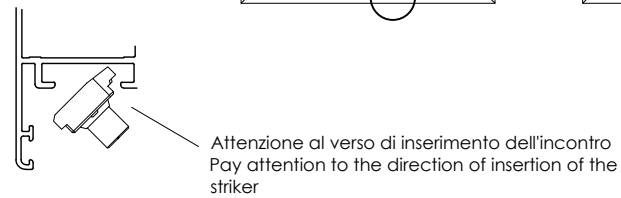
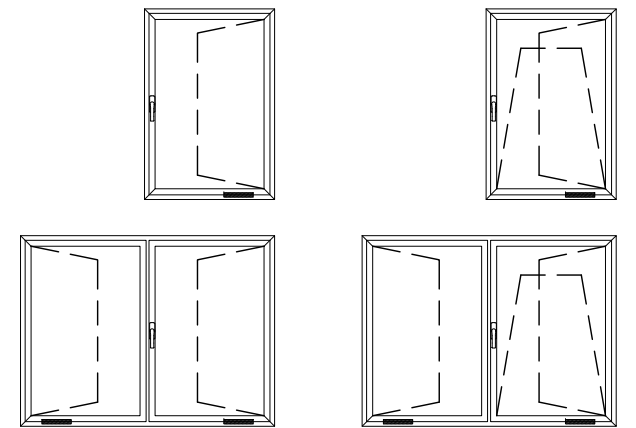
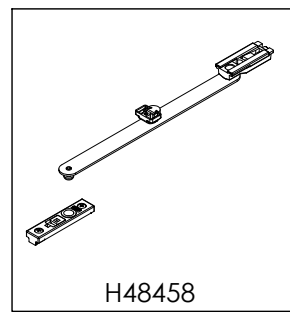
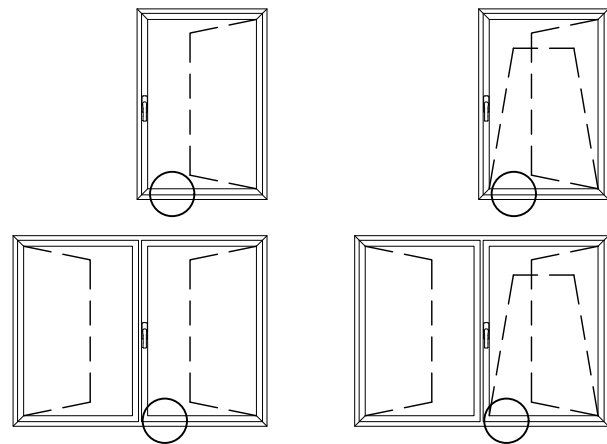
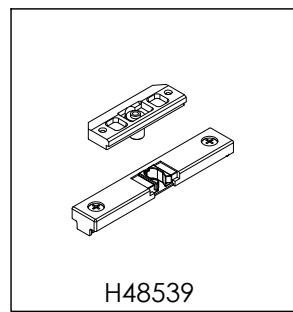

Nottolino per sgancio braccetto
Arm releasing catch

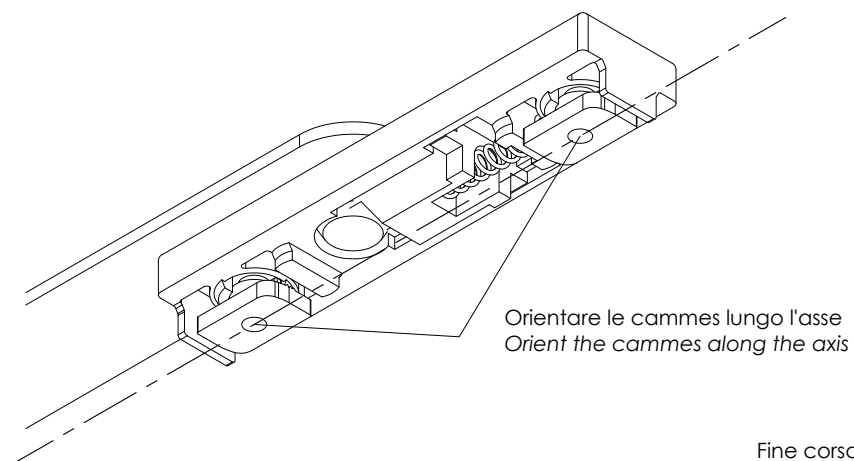

Fine corsa regolabile
Adjustable stroke-end

Vite di regolazione frizione
Friction adjustment screw

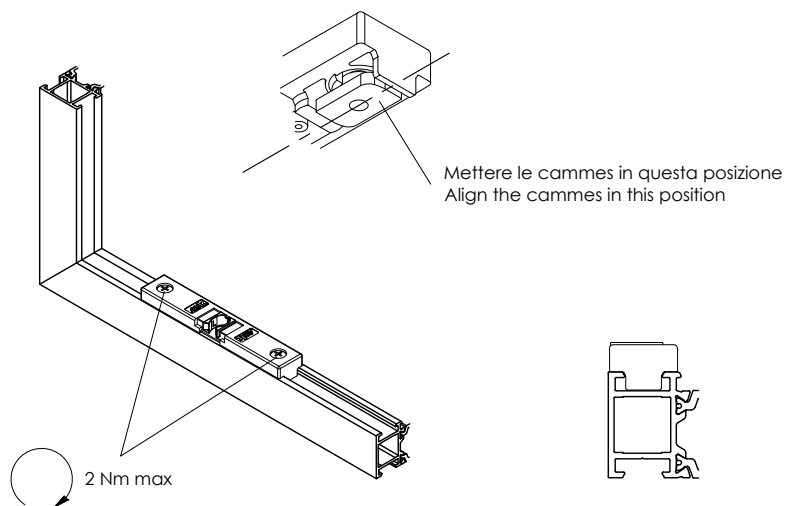

RIEPILOGO FERRAMENTA VASISTAS BOTTOM-HUNG WINDOW HARDWARE SUMMARY

C67K	C77K	C77K-CS	C67K-M
●	●	●	○
		C45K-NI	C55K-NI
		●	●

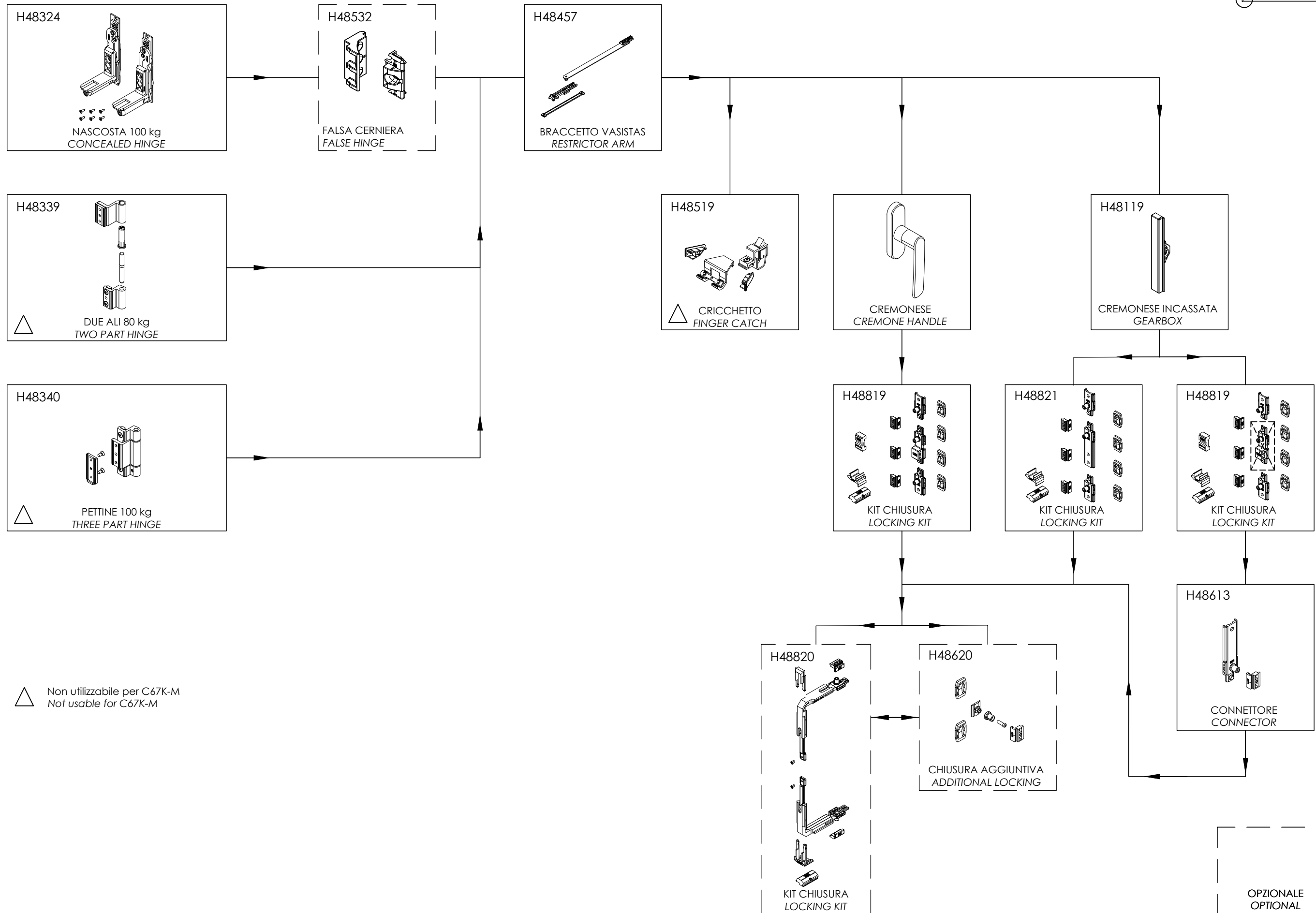
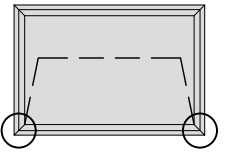

△ Non utilizzabile per C67K-M
Not usable for C67K-M

MONTAGGIO CERNIERE NASCOSTE APERTURA A VASISTAS 100 kg
100 kg BOTTOM-HUNG OPENING CONCEALED HINGE ASSEMBLING

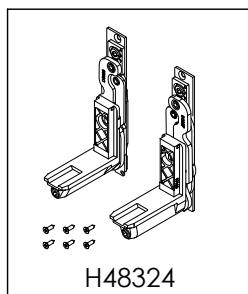
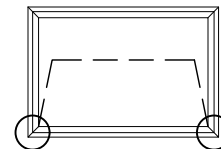

1) Inserire le cerniere sul profilo d'anta
 Insert hinges in sash groove

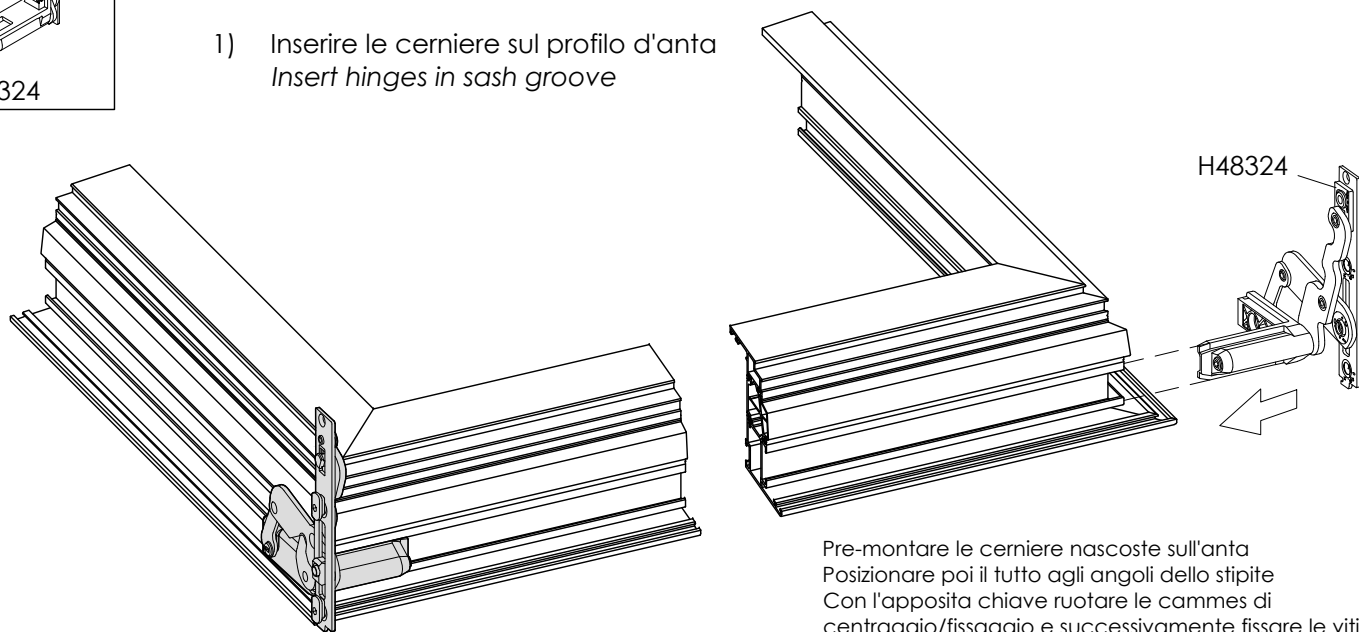

Pre-montare le cerniere nascoste sull'anta
 Posizionare poi il tutto agli angoli dello stipite
 Con l'apposita chiave ruotare le camme di centraggio/fissaggio e successivamente fissare le viti

First step: install the concealed hinges on the sash
 Second step: position the hidden hinges in the corners of the frame
 Third step: with the specific tool rotate the centring/fixing cammes and then fit the screws

2) Inserire l'anta nel telaio
 Insert sash in frame section

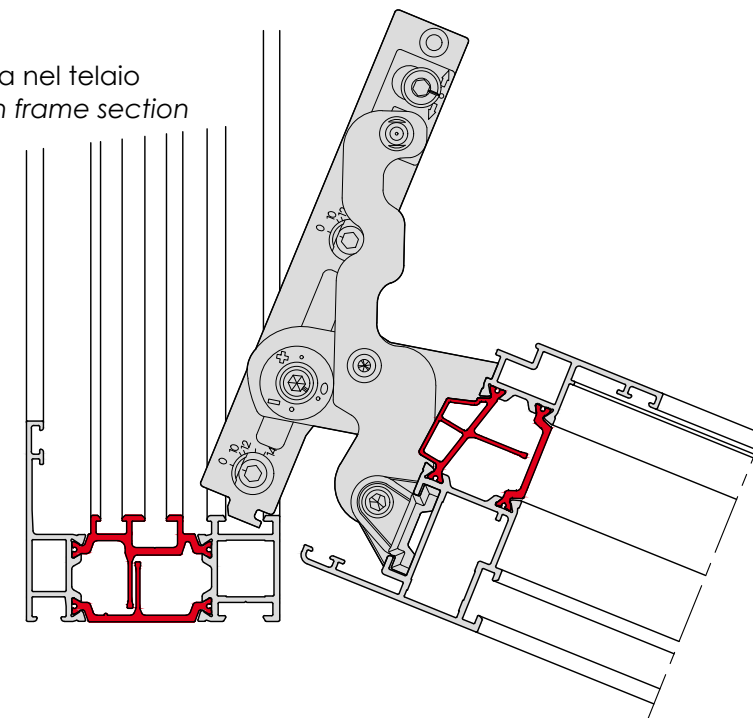

3-7) Regolare la cerniera e fissarla con le viti
 Adjust the hinge and fix it with screws

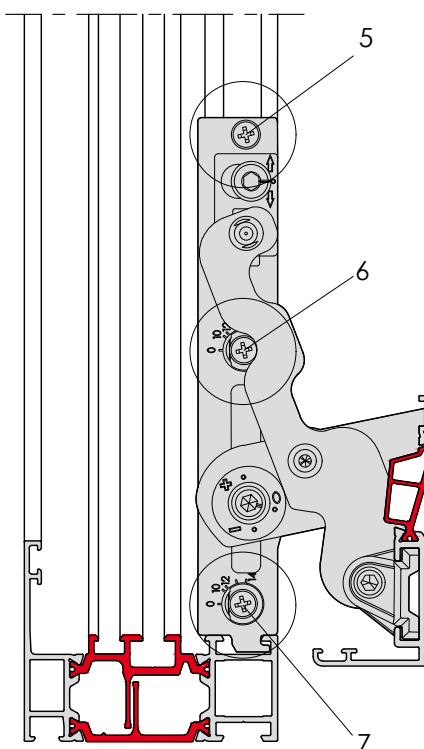
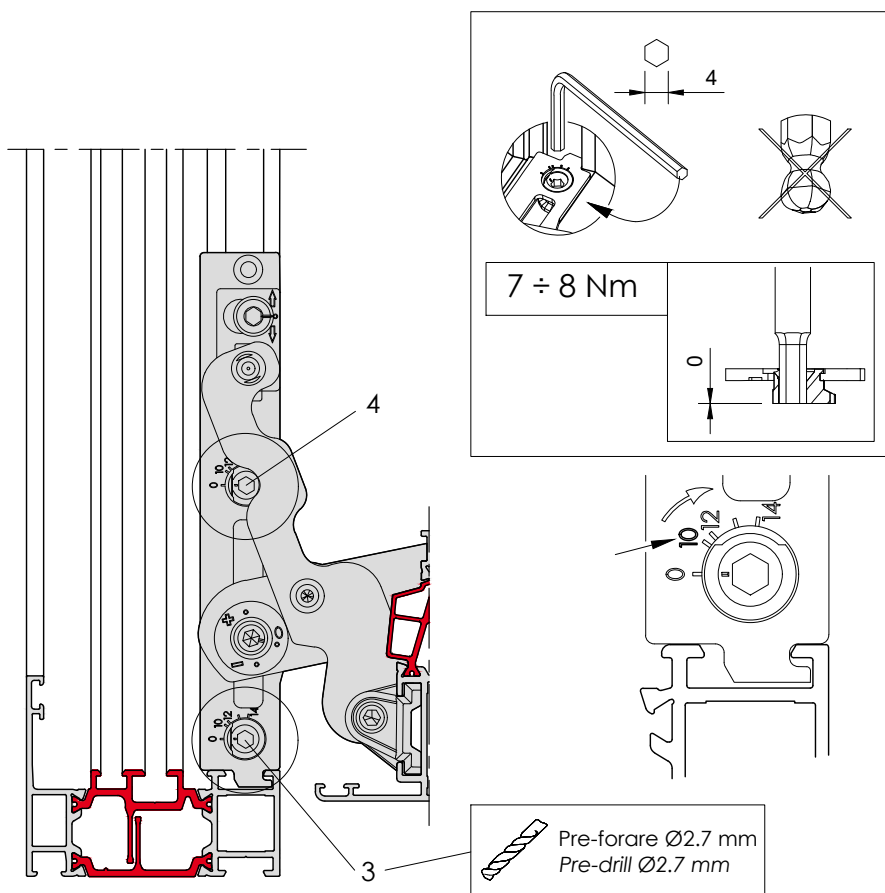

REGOLAZIONE CERNIERE
HINGE ADJUSTMENT

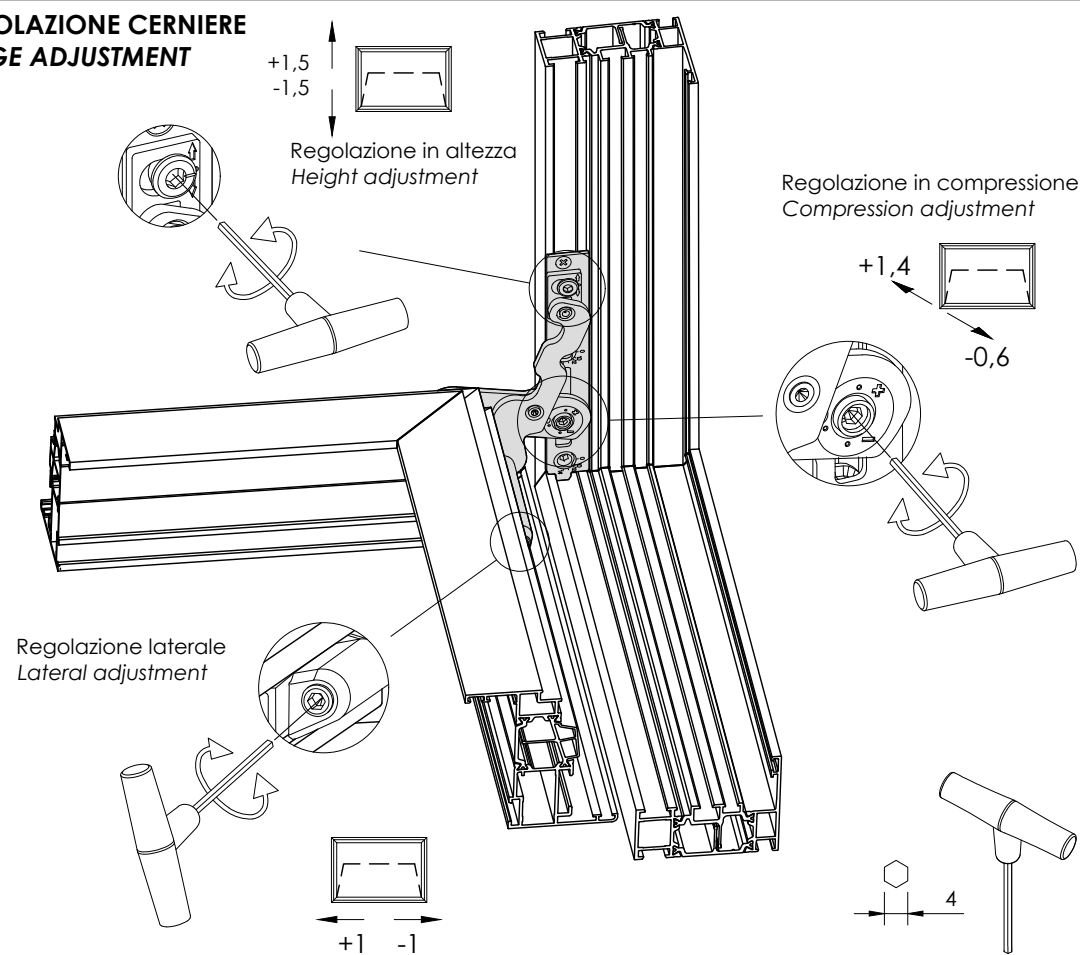

➤ MONTAGGIO CERNIERE DUE ALI 80 kg E CERNIERE PETTINE 100 kg
80 kg TWO-PART AND 100 kg THREE-PART HINGE ASSEMBLING

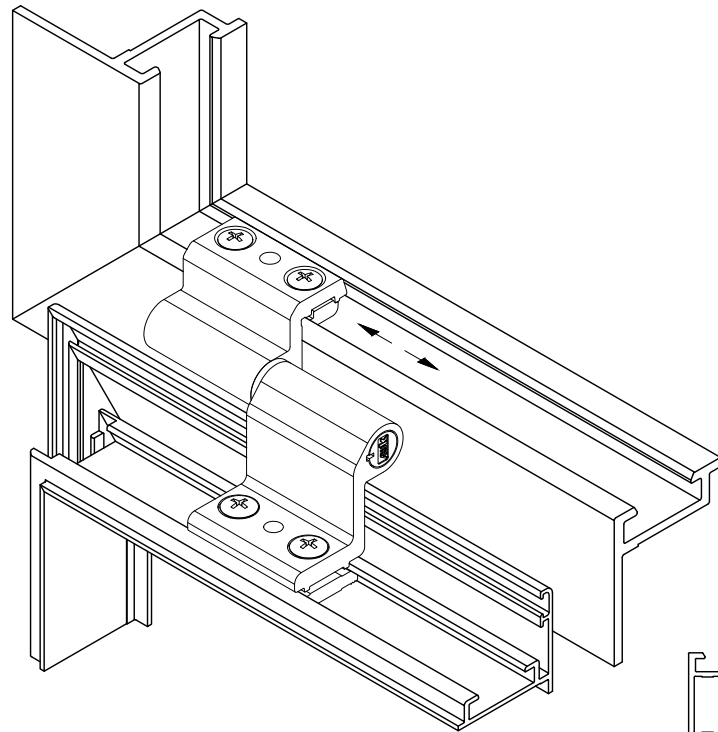
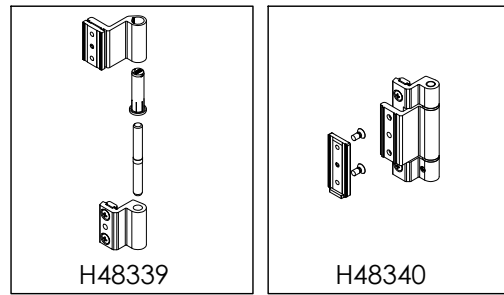
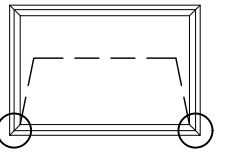

Per il montaggio delle cerniere vedere le pagine dedicate al montaggio delle cerniere battente repertorio 10.4.X

For the hinges assembly see the turn-only hardware dedicated pages 10.4.X

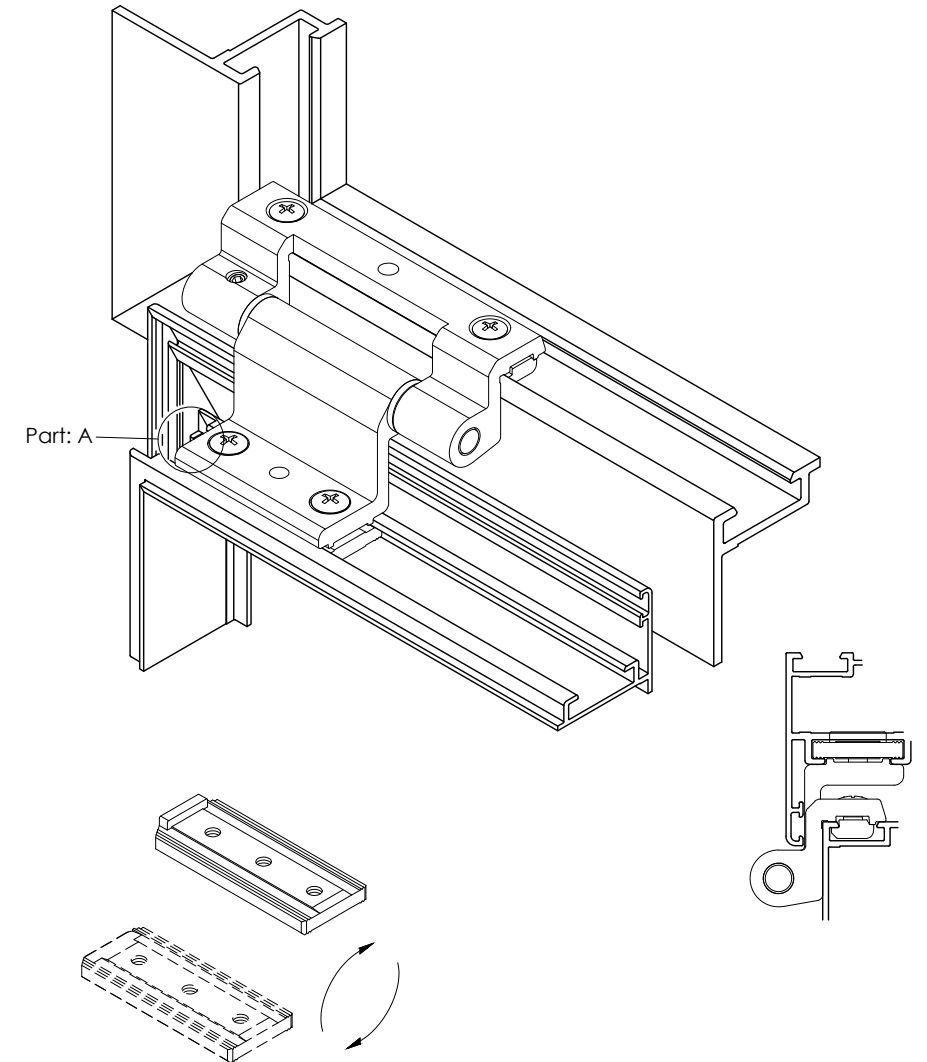
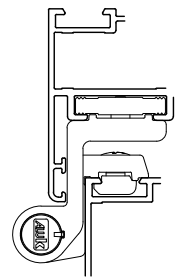

Per il montaggio di cerniere intermedie ruotare la contropiastra con il dentello verso l'esterno

For the assembling of intermediate hinges, rotate the counter-plate with tooth outwards

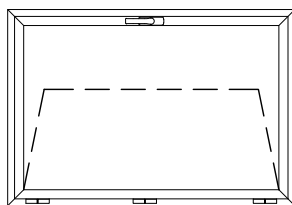
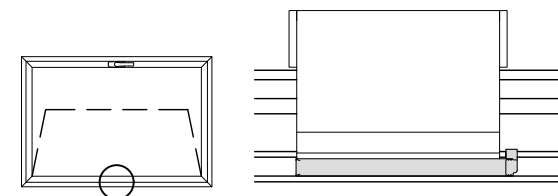

Posizionare la cerniera agli estremi
Montare una cerniera centrale per LB > 1200 mm
(con carico di vento 800 Pa)

Position the hinge at the ends
Mount a central hinge for LB > 1200 mm
(under wind load at 800 Pa)

MONTAGGIO CRICCHETTO VASISTAS
FINGER CATCH ASSEMBLING

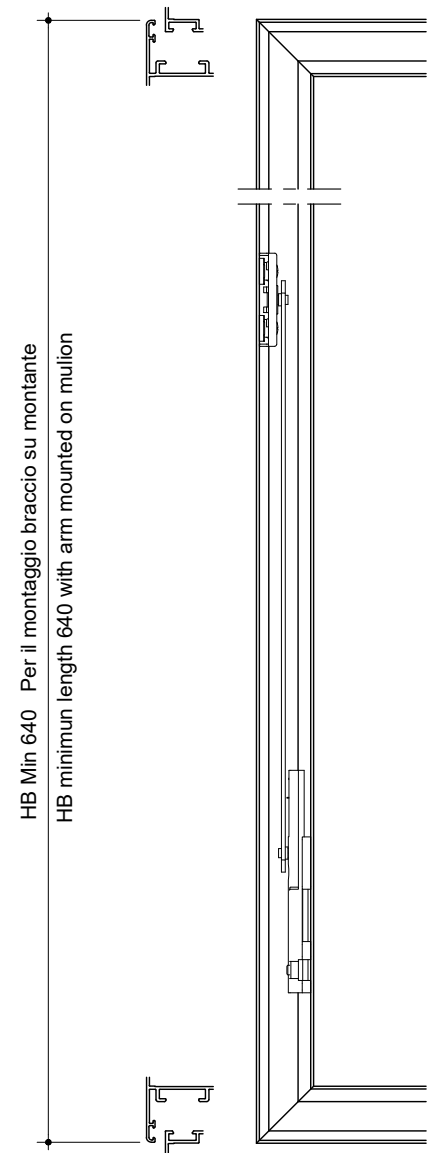
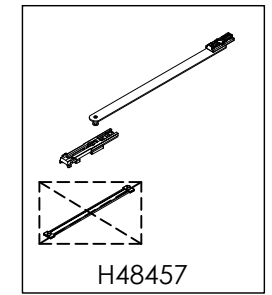
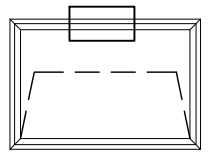
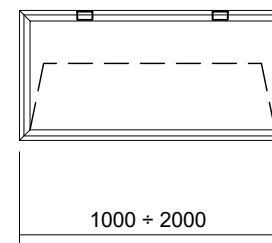
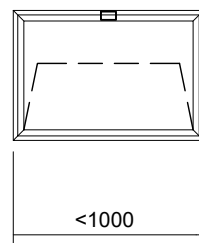
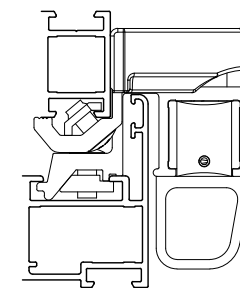
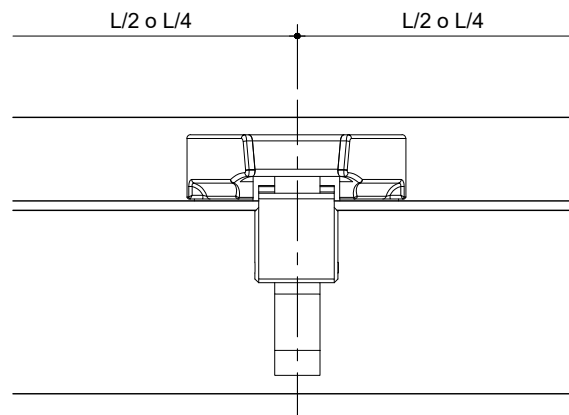
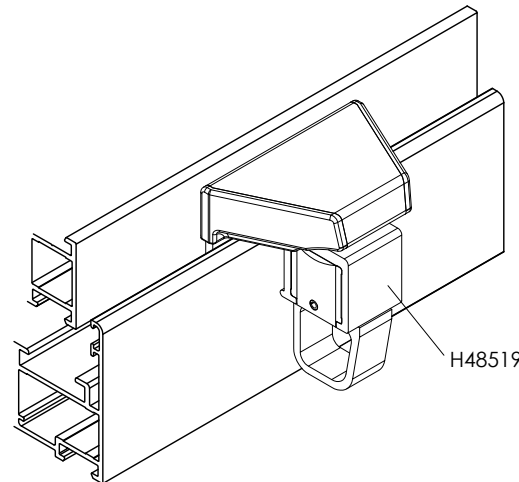
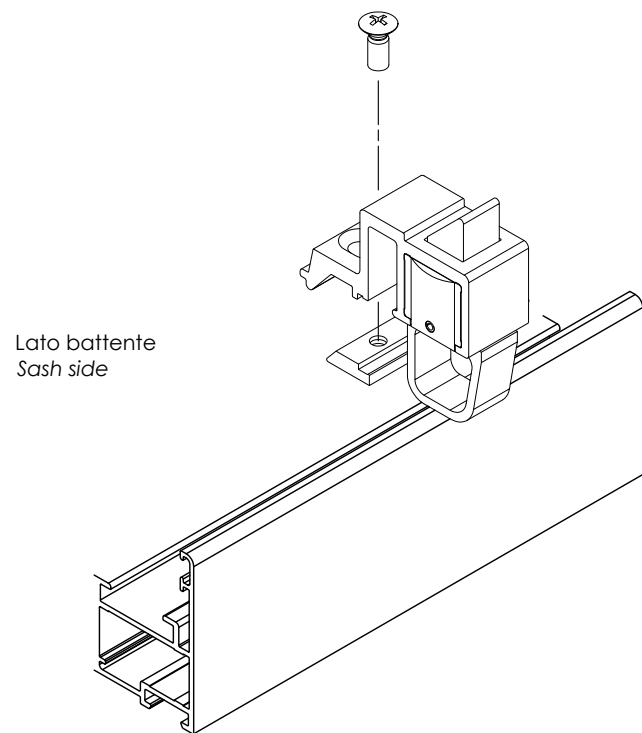
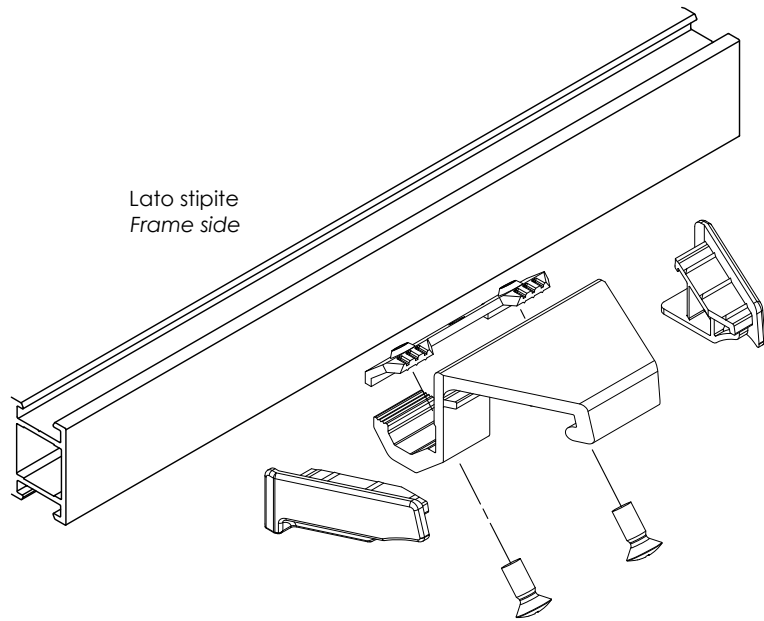
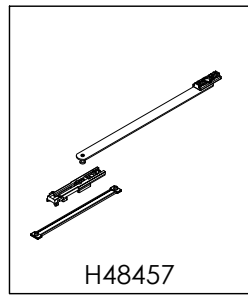
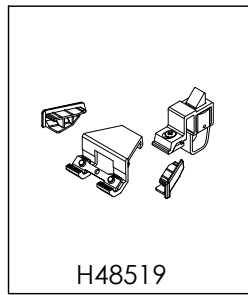

➤ MONTAGGIO BRACCETTO VASISTAS CON 3 PUNTI DI CHIUSURA SUL TRAVERSO
 RESTRICTOR ARM ASSEMBLING WITH THREE LOCKINGS ON TOP TRANSOM

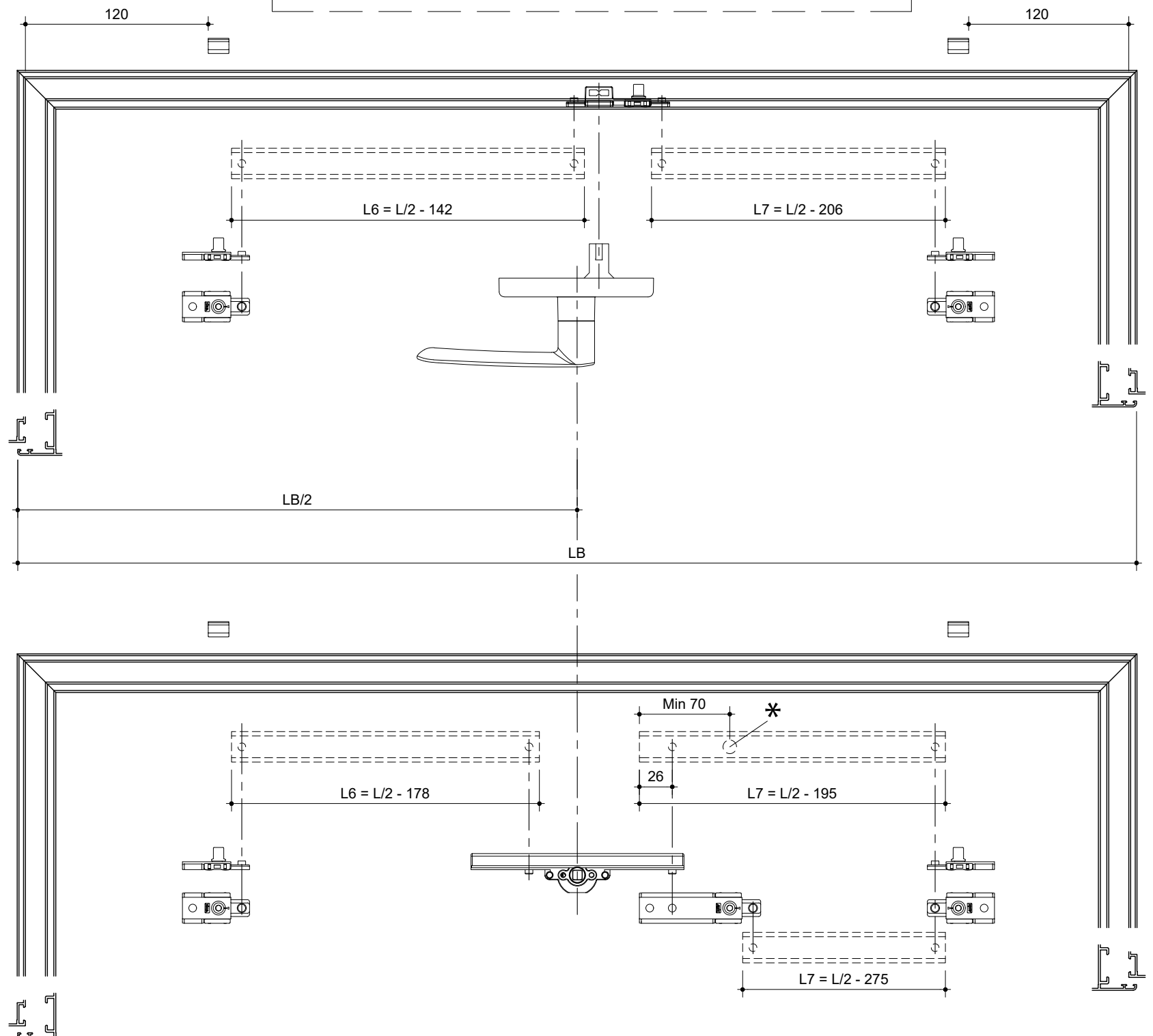
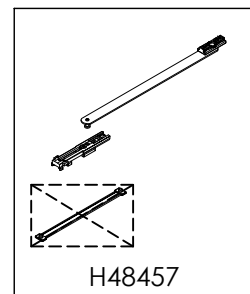
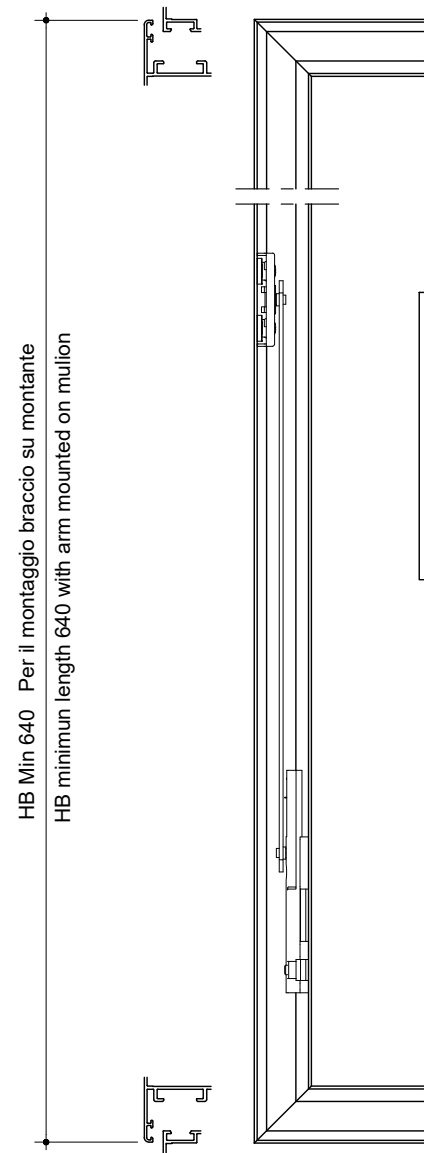
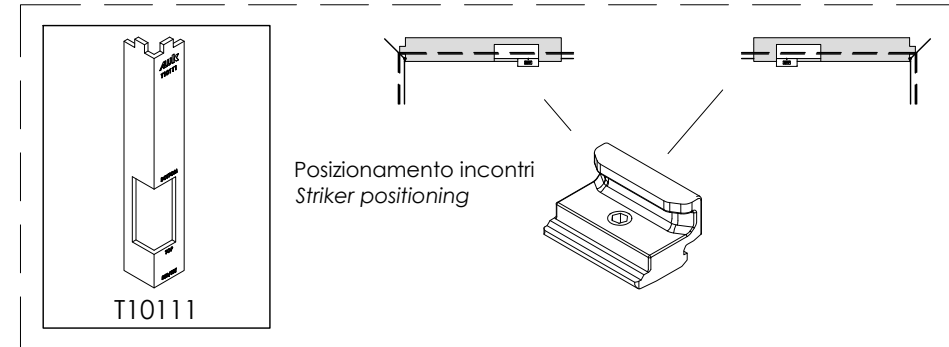
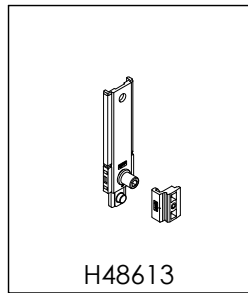
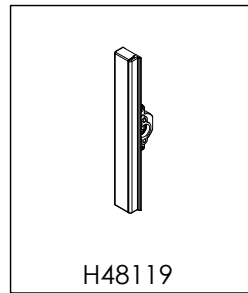
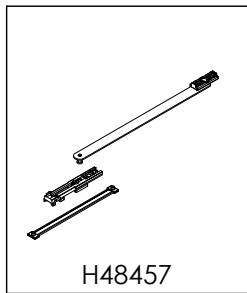
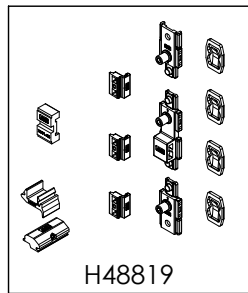
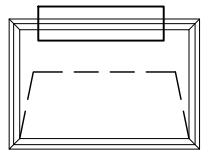

➤ MONTAGGIO BRACCETTO VASISTAS sul traverso CON 3/4 PUNTI DI CHIUSURA
 RESTRICTOR ARM ASSEMBLING on top transom WITH THREE / FOUR LOCKINGS

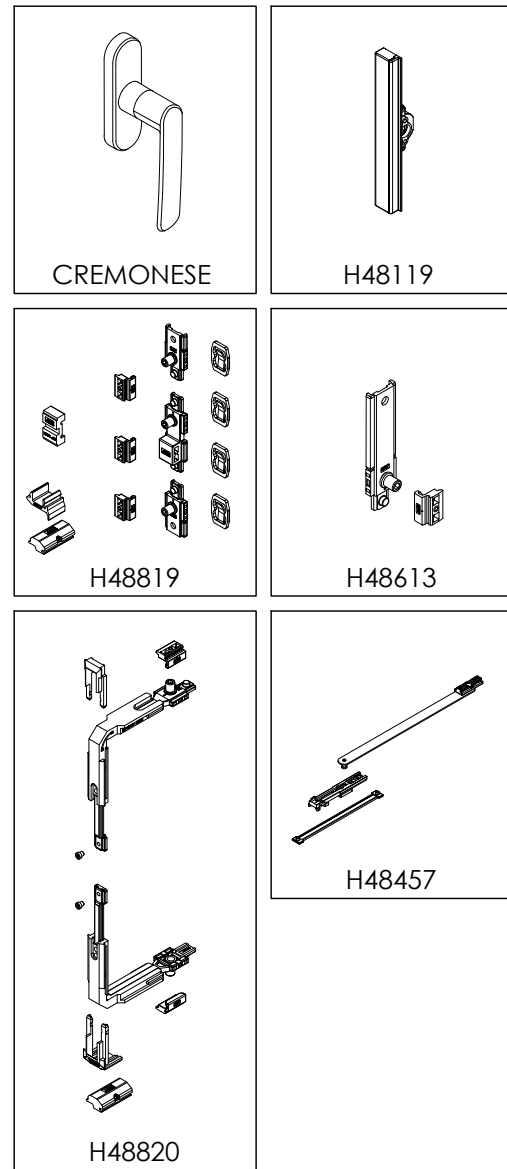
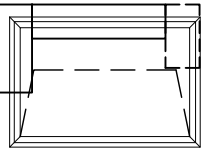

Per finestre di grandi dimensioni si consiglia l'impiego della motorizzazione
 Per HB>700 non superare l'angolo di apertura di 20°
 Per i diagrammi dimensionali vedere tavole di dimensionamento

For large windows, we suggest the installation of electric actuators
 if HB>700 the opening angle must not exceed 20°
 See maximum dimensions on dedicated diagrams

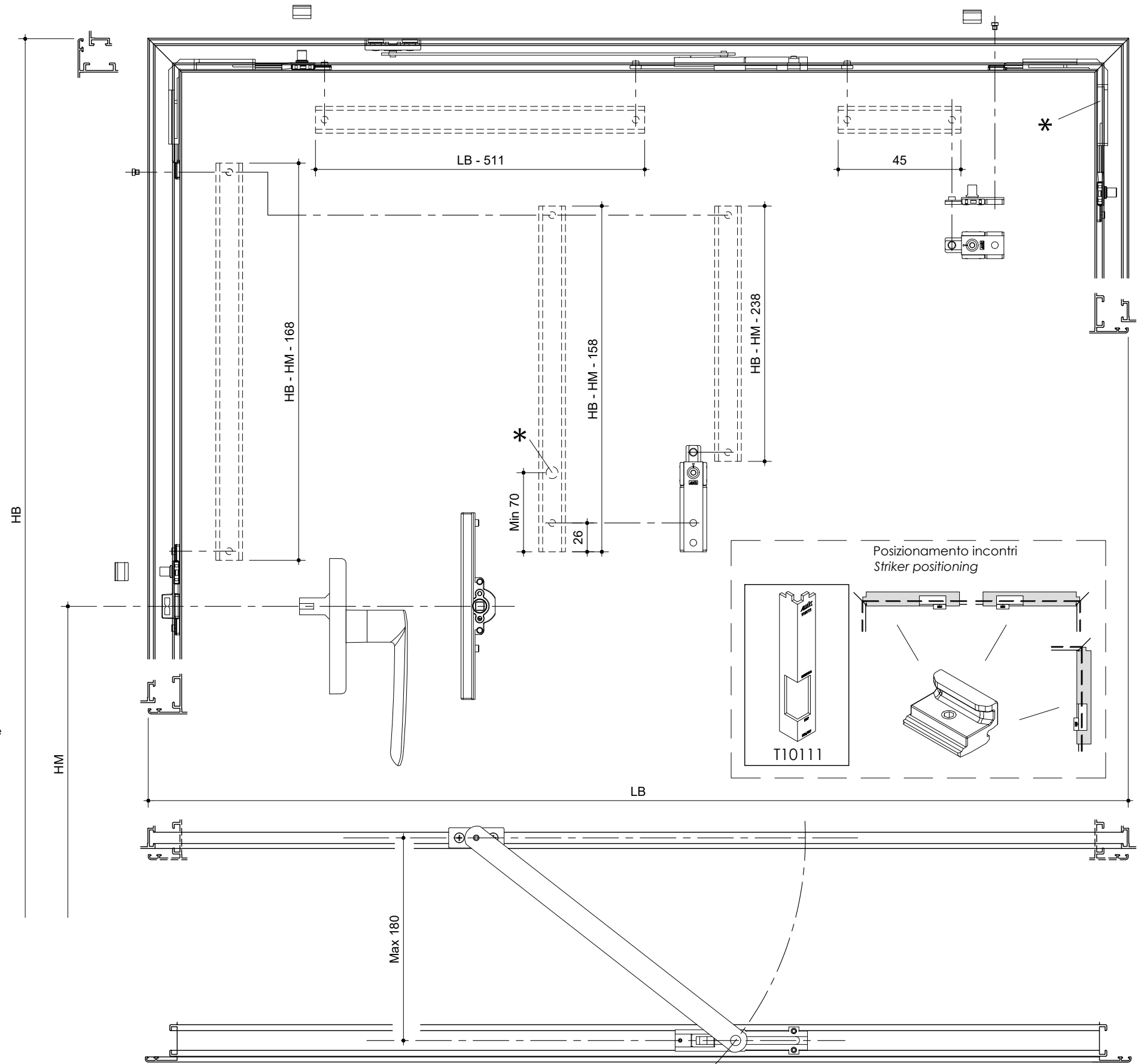
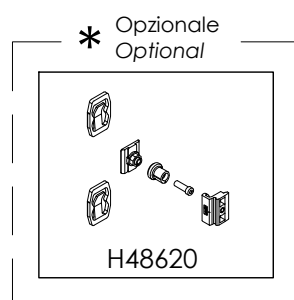

➤ **MONTAGGIO BRACCETTO VASISTAS sul montante CON 3/4 PUNTI DI CHIUSURA**
RESTRICTOR ARM ASSEMBLING on mullion WITH THREE / FOUR LOCKINGS

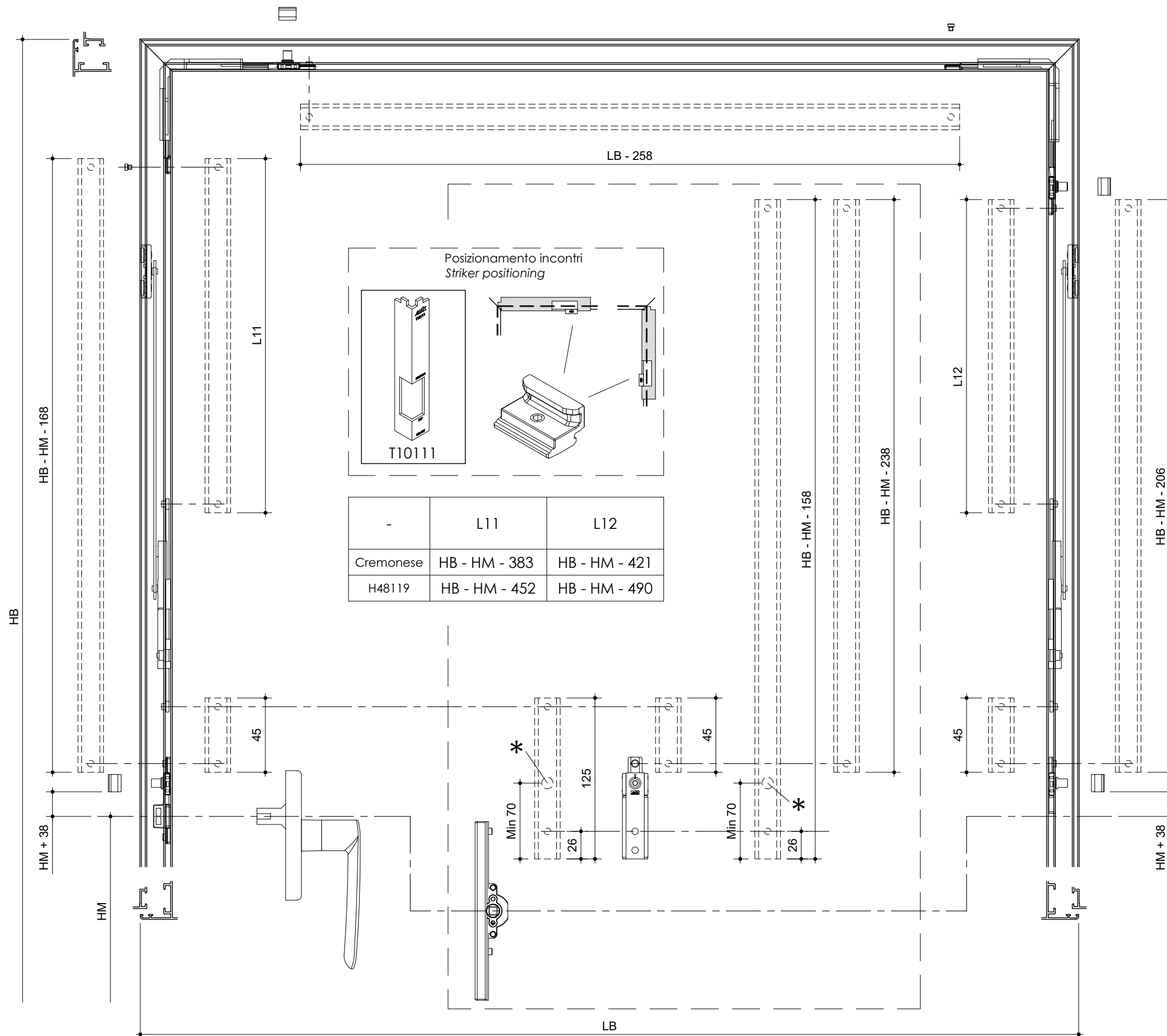
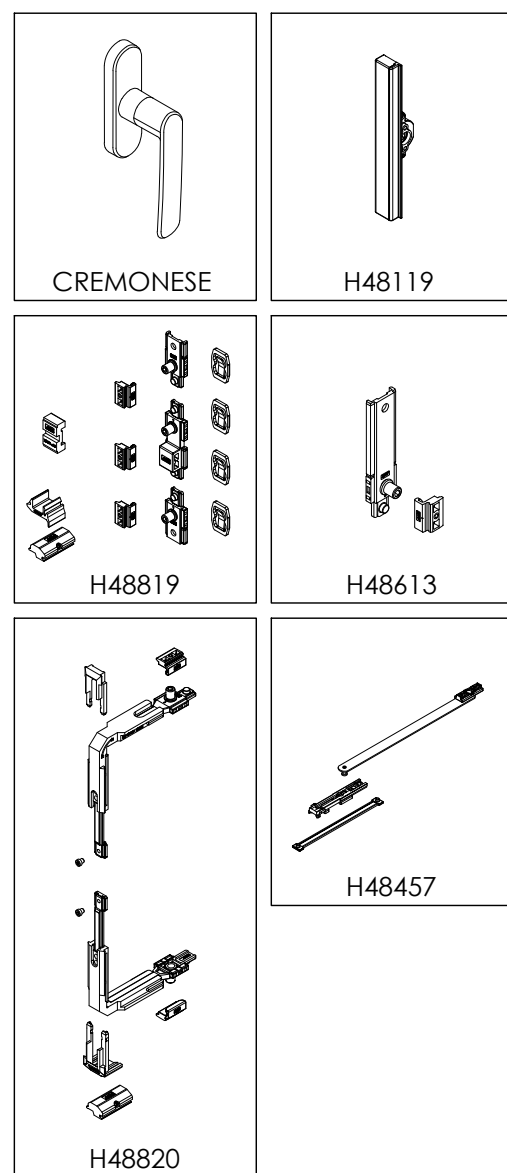
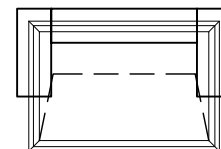

Per finestre di grandi dimensioni si consiglia l'impiego della motorizzazione
 Per HB>700 non superare l'angolo di apertura di 20°
 Per i diagrammi dimensionali vedere tavole di dimensionamento

For large windows, we suggest the installation of electric actuators
 if HB>700 the opening angle must not exceed 20°
 See maximum dimensions on dedicated diagrams

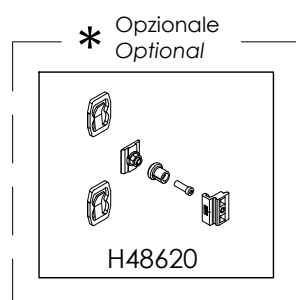

RIEPILOGO FERRAMENTA SPORGERE
PROJECTING WINDOW HARDWARE SUMMARY

C67K	C77K	C77K-CS
●		

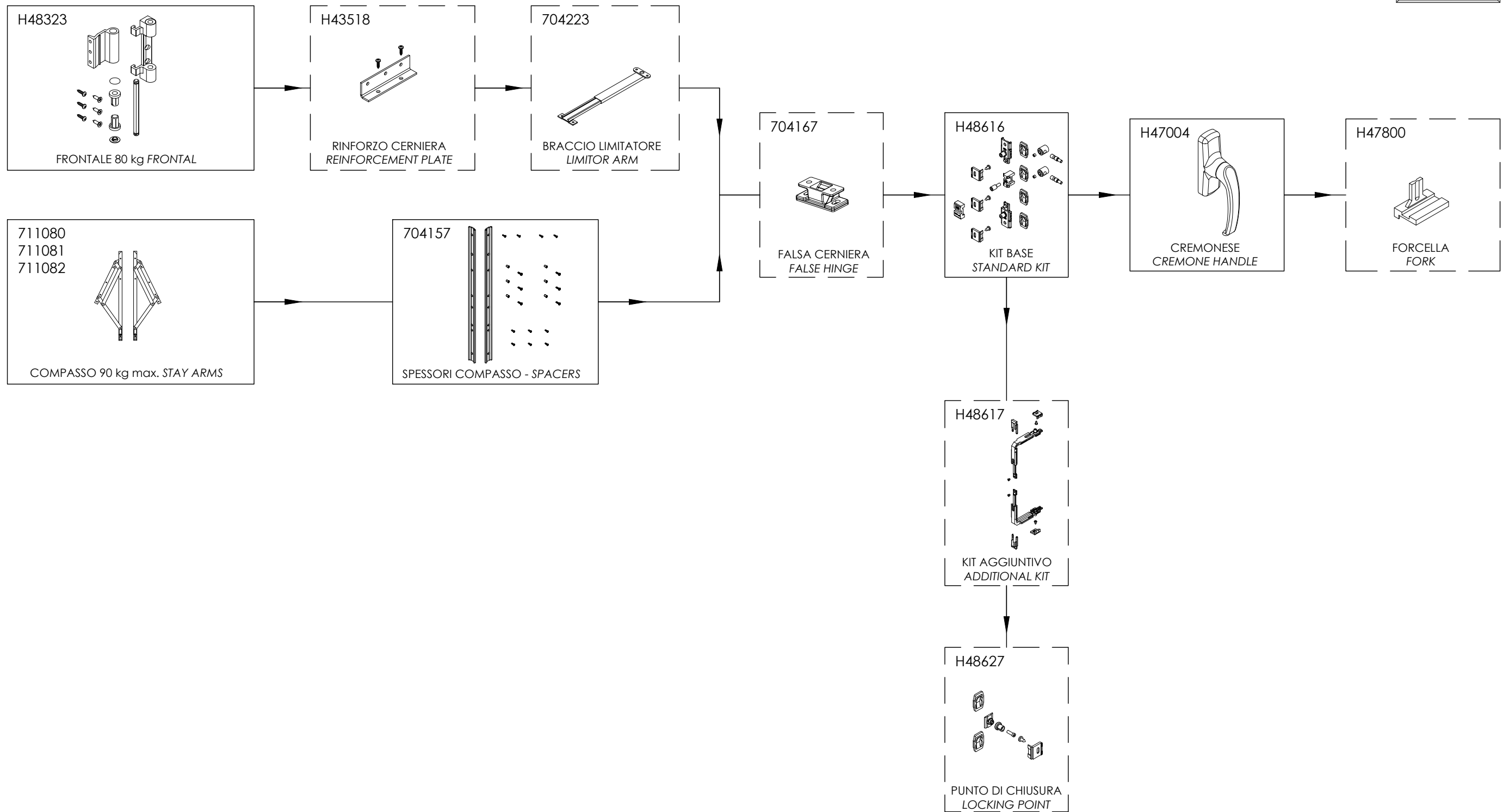
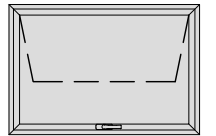

OPZIONALE
OPTIONAL

MONTAGGIO CERNIERA PER FINESTRA A SPORGERE
PROJECTING WINDOW WITH FRONTAL HINGES ASSEMBLING DIAGRAM

C67K	C77K	C77K-CS
●		

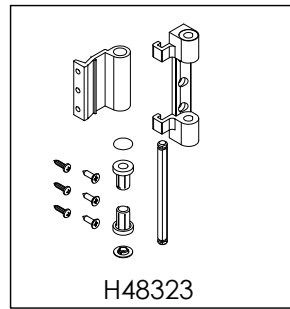
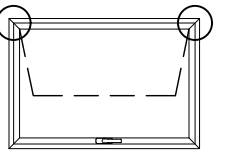

MONTAGGIO SEMICERNIERA SU STIPITE "z"
 HINGE ASSEMBLING ON "z-shaped" OUTER FRAME

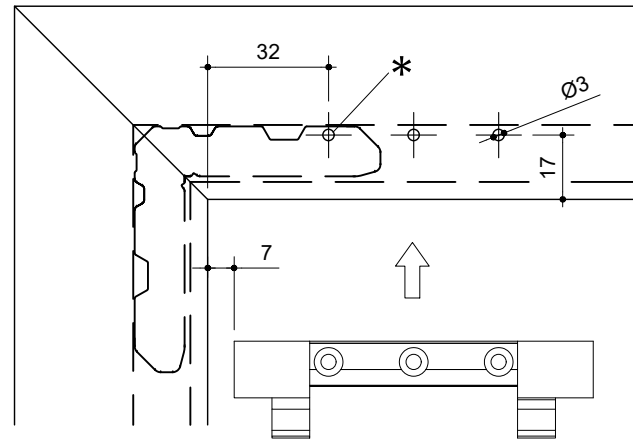

U20021
(U20006)

* Pre-forare Ø3 il profilo utilizzando le
 semicerniere come dima
 Pre-drill Ø3 the profile using the
 semi-hinge as drilling template

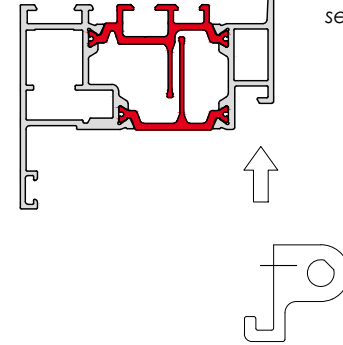

MONTAGGIO SEMICERNIERA BATTENTE
 SEMI-HINGE WING ASSEMBLING

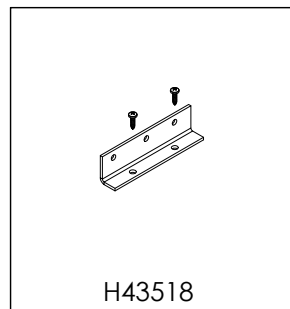
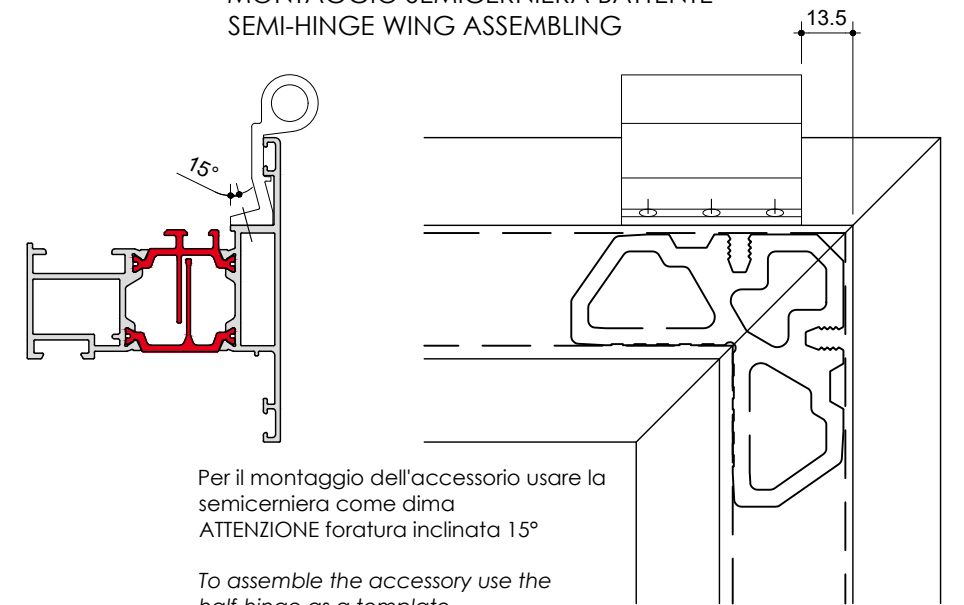

MONTAGGIO SEMICERNIERA SU STIPITE CON INVERSIONE BATTUTA
 HINGE ASSEMBLING ON OUTER FRAME WITH REVERSAL PROFILE

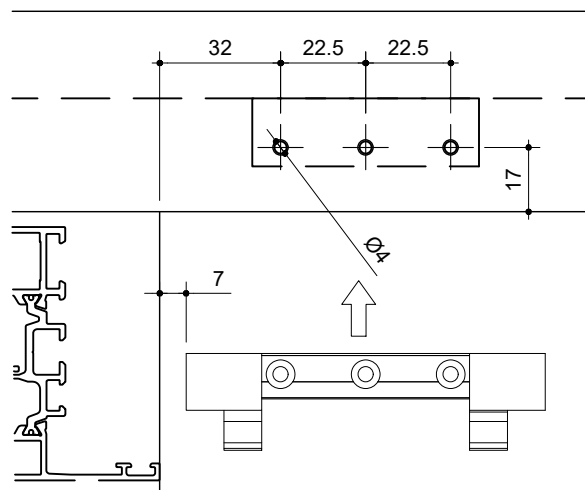

U20000

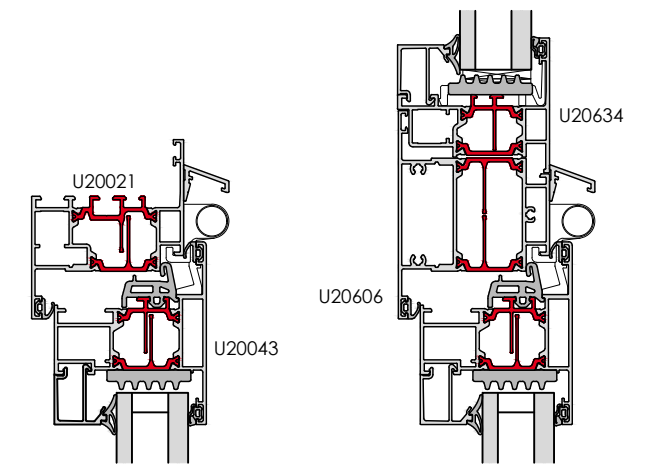
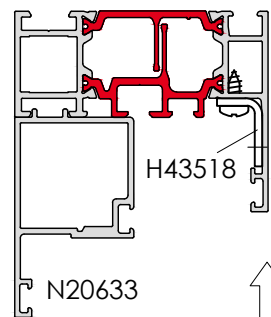

MONTAGGIO DELLA GUARNIZIONE V03023
 V03023 GASKET ASSEMBLING

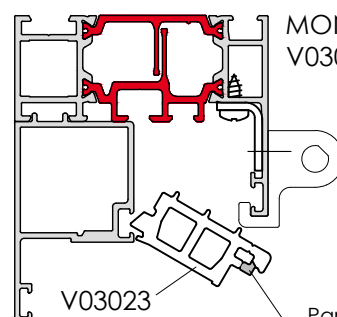

Parte da asportare in corrispondenza delle alette della cerniera
 Part to be removed in correspondence with the wings of the hinge

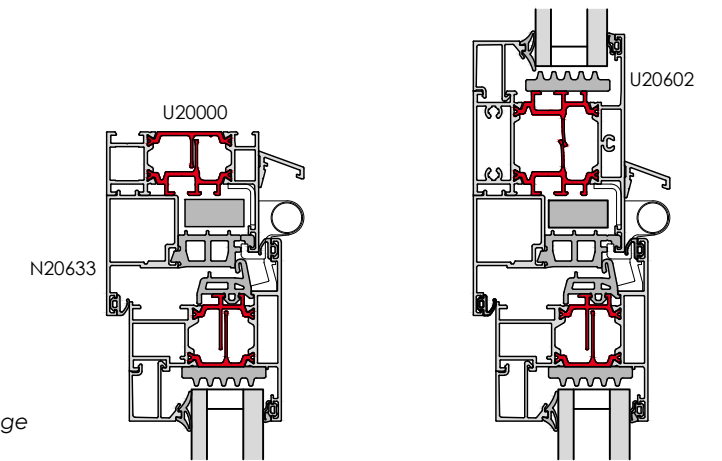

MONTAGGIO COMPASSI PER FINESTRA A SPORGERE STAY ARMS ASSEMBLING DIAGRAM ON PROJECTING WINDOW

C67K	C77K	C77K-CS
●		

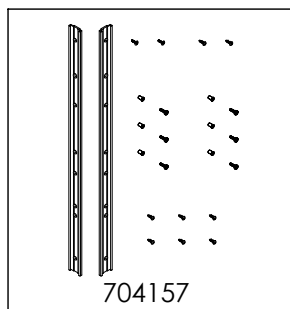
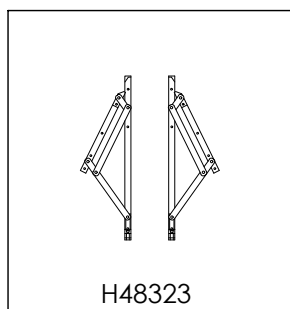
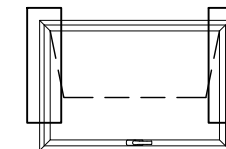

704157	711081	711080	711082
T[mm]=	285	365	467.5

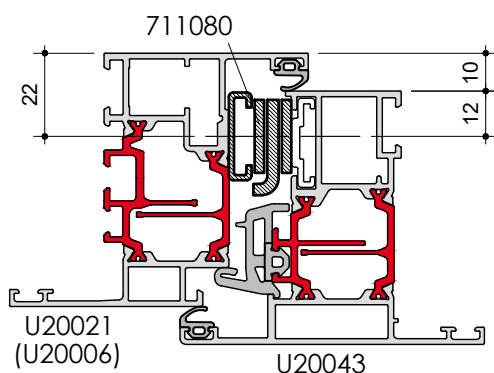
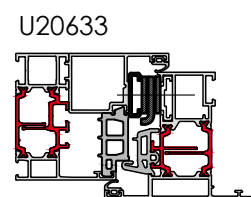
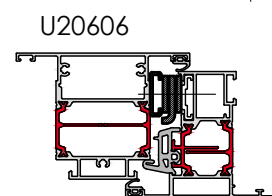
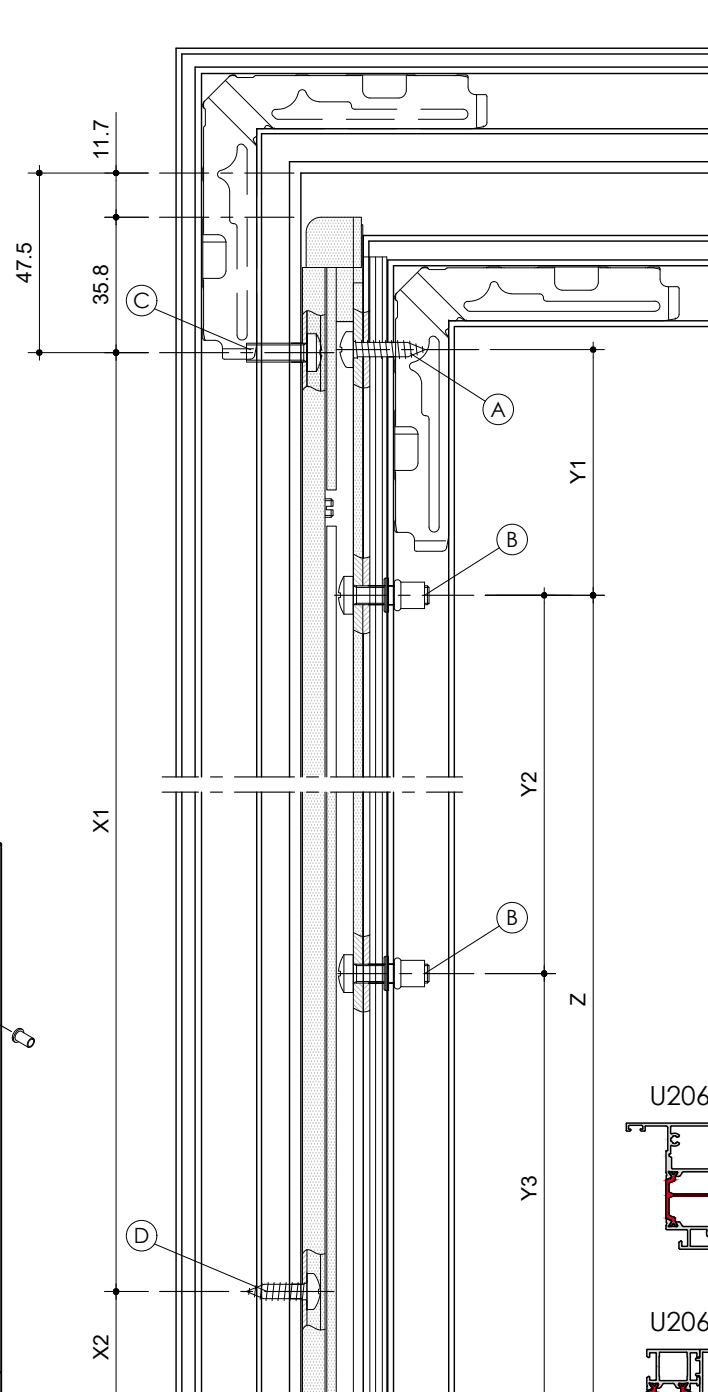
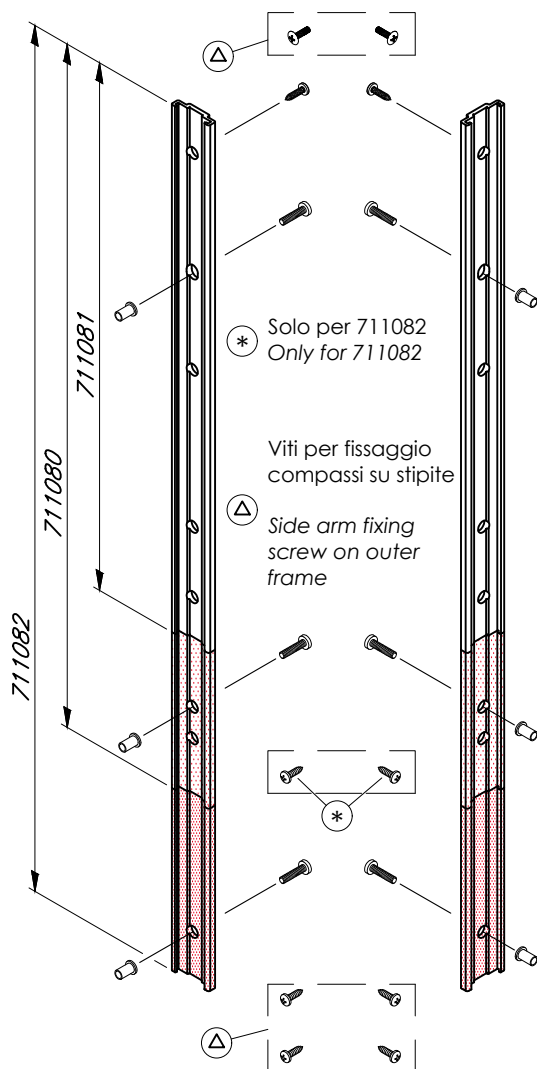

Aumentare i punti di fissaggio del profilo U20633 in corrispondenza del compasso

Increase the fixing points of the U20633 profile in correspondence with the side arm

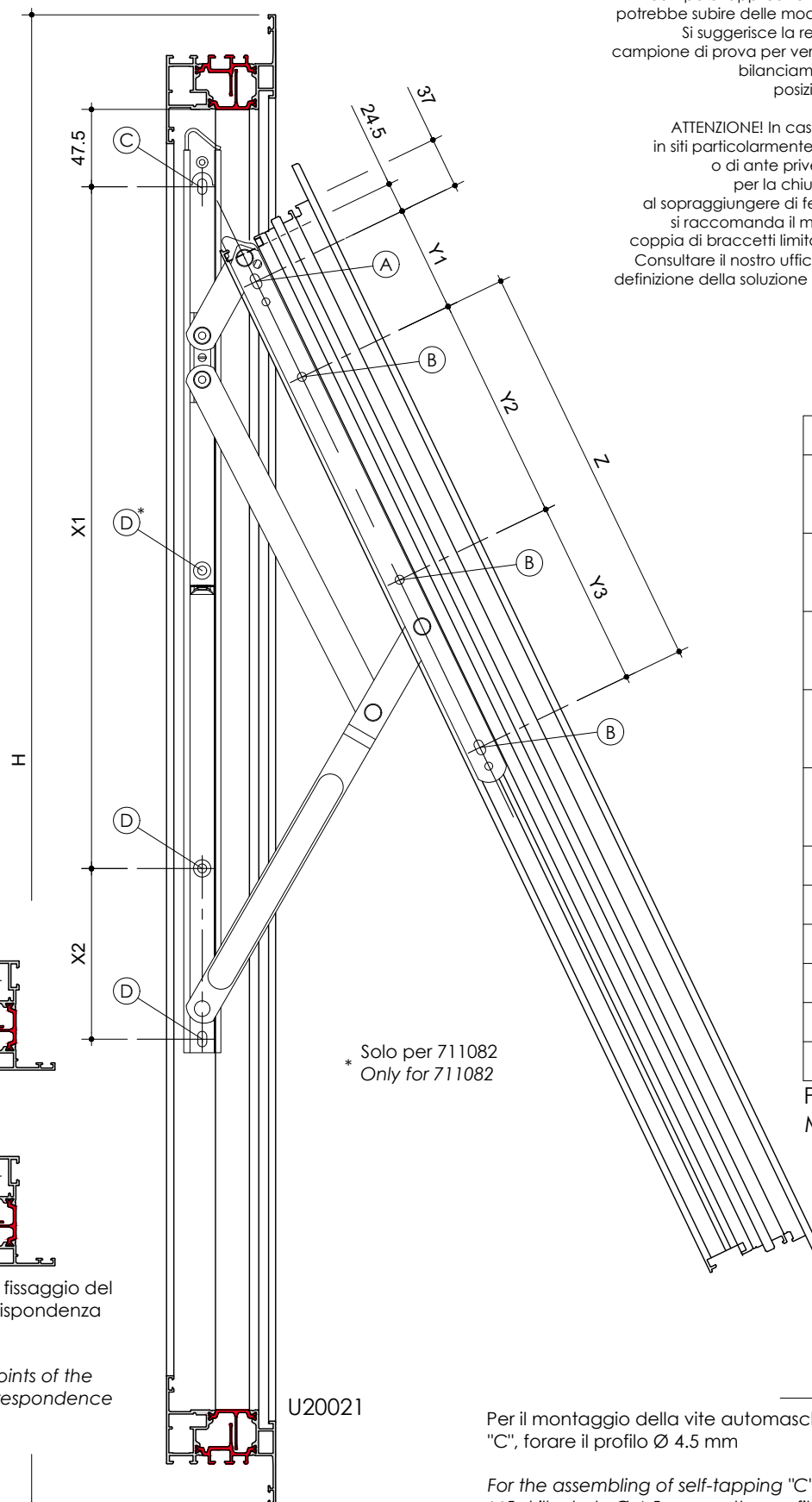

ATTENZIONE! Per alcune particolari composizioni e spessori del vetro, il campo di applicazione del compasso potrebbe subire delle modifiche in altezza. Si suggerisce la realizzazione di un campione di prova per verificare il corretto bilanciamento dell'anta in posizione di apertura.

WARNING! For some particular glass compositions and thicknesses, the application range of the arms may undergo changes in height. We suggest the realization of a test sample to verify the correct balancing of the sash.

ATTENZIONE! In caso di installazione in siti particolarmente esposti al vento o di ante prive di automatismi per la chiusura motorizzata al sopraggiungere di fenomeni ventosi, si raccomanda il montaggio di una coppia di braccetti limitatori di apertura. Consultare il nostro ufficio tecnico per la definizione della soluzione più appropriata.

WARNING! In the case of installation in sites particularly exposed to the wind or in case of sashes without automatic controls for the motorized closing when a wind event is coming, it is recommended to install a pair of stay open restrictors. Please contact our technical department for the definition of the best solution in this situation.

TABELLA FORATURA E PORTATA
DRILLING TABLE AND MAX WEIGHT

COD	711081	711080	711082
Altezza min Min height	790	1100	1300
Altezza max Max height	1090	1500	1800
Larghezza max Max width	1200	1500	2000
Portata Max weight	55	100	90
Apertura max α Max opening α	50°	45°	23°
X1	304	418.4	585
X2	66.6	104.7	52
Y1	117	65	65
Y2	-	138.2	234
Y3	-	114.2	121.5
Z	122.8	-	-

Portate espresse in [kg]
Max weight [kg]

SEQUENZA DI FISSAGGIO VITI
SCREWS FIXING SEQUENCE

- (A) Autof. 4.8x19 UNI 7049
- (B) Vite TC M5x20 UNI 7687 + Insetto fil. M5
- (C) Vite automaschiante TC M5x15 UNI 8112
- (D) Autof. 4.8x16 UNI EN ISO 7049

Per il montaggio della vite automaschiante "C", forare il profilo \varnothing 4.5 mm

For the assembling of self-tapping "C" screw M5 drill a hole \varnothing 4.5 mm on the profile

MONTAGGIO CREMONESE SPORGERE
PROJECTING WINDOW CREMONE-HANDLE ASSEMBLING

C67K	C77K	C77K-CS
●		

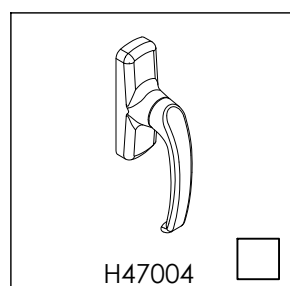
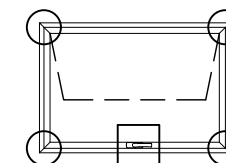

POSIZIONAMENTO DEL BLOCCO
 MANIGLIA A 90° PER CREMONESE

POSITIONING OF 90° LOCK FOR HANDLE

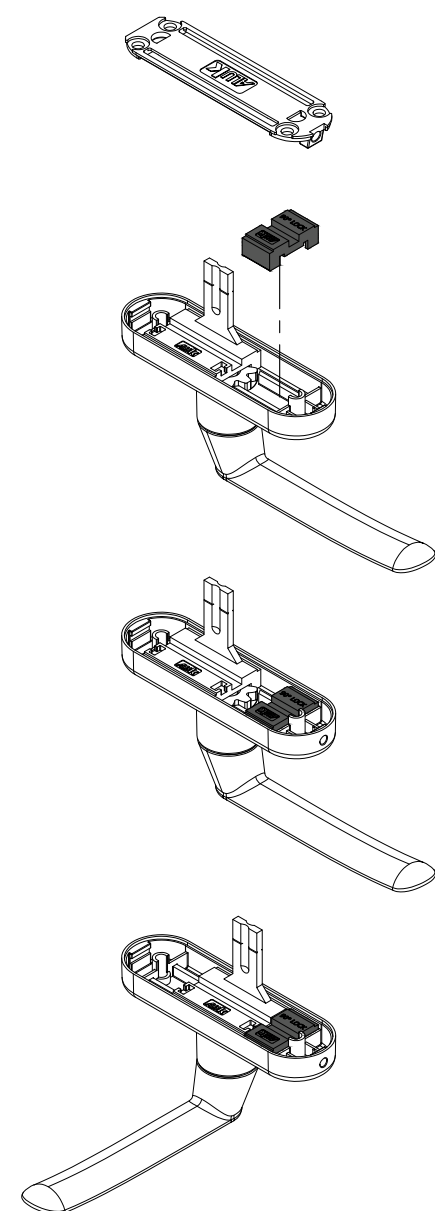

Posizionare il componente prima
 dell'inserimento dell'asta N48900

Position the component before
 inserting the N48900 rod

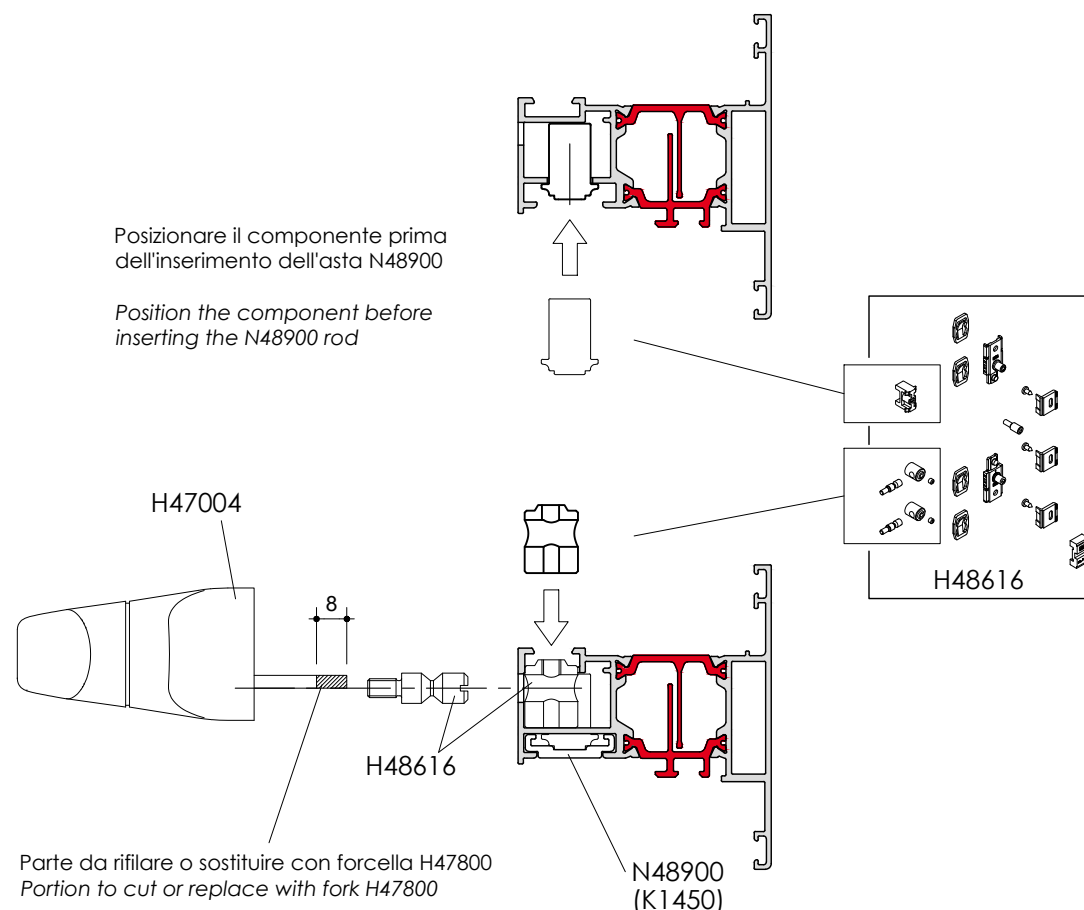

Parte da rifilare o sostituire con forcetta H47800
 Portion to cut or replace with fork H47800

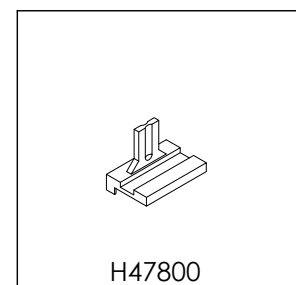

Lavorazione fermavetro da eseguire
 in zona aggancio cremone

Glazing bead machining in cremone
 connection area

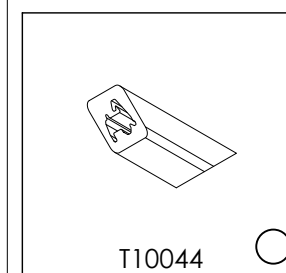
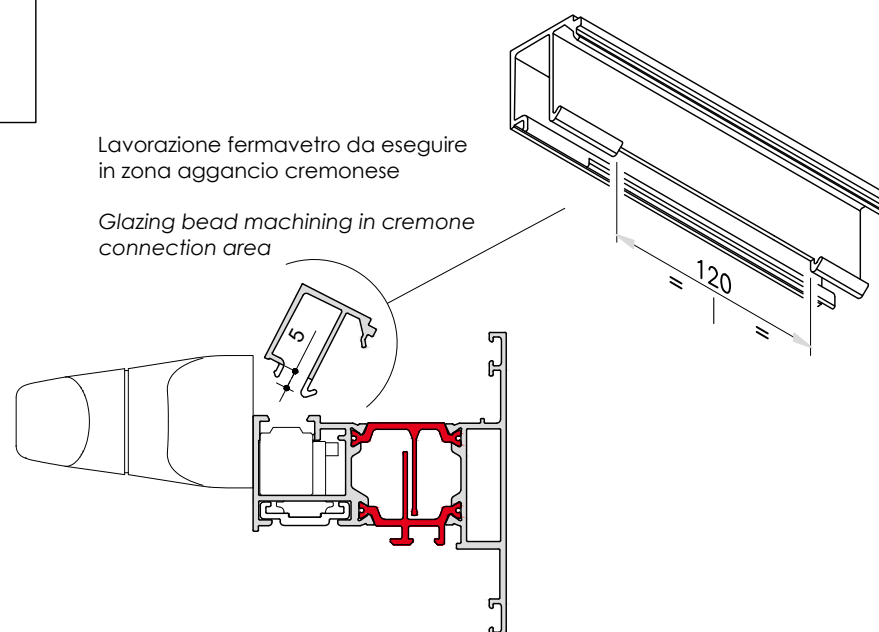

TAGLIO GUARNIZIONE GIUNTO APERTO PER SPORGERE
 GASKET CUT CENTRAL GASKET FOR PROJECTING

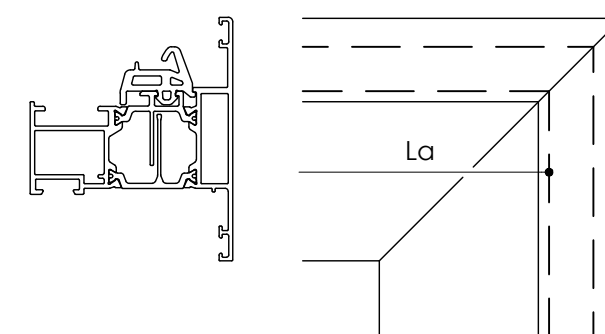
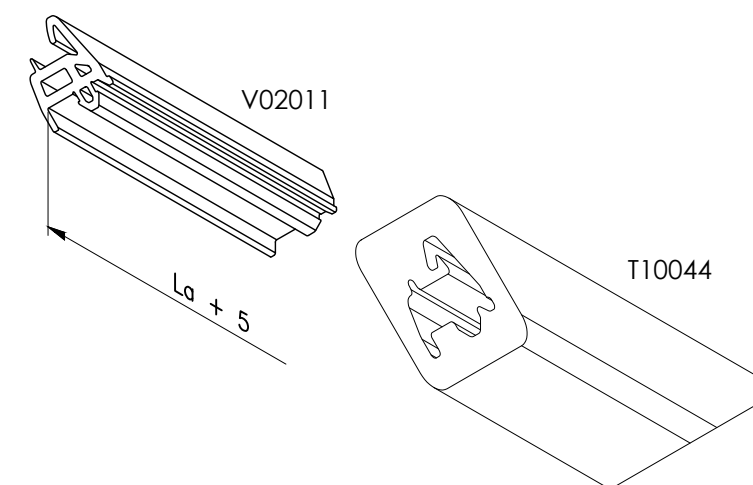

MONTAGGIO Limitatore e falsa cerniera PER FINESTRA A SPORGERE Limitor arm and false hinge ASSEMBLING ON PROJECTING WINDOW

C67K	C77K	C77K-CS
●		

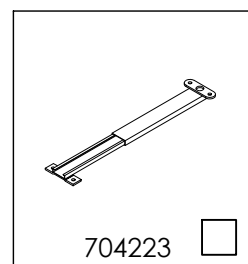
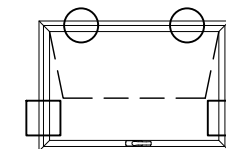

Il limitatore è da usarsi con la soluzione cerniera
 The limiter has to be used with the hinge solution

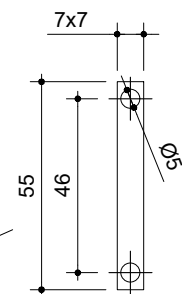

Spessore non fornito
 Spacer plate not supplied

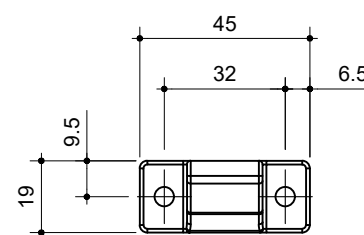
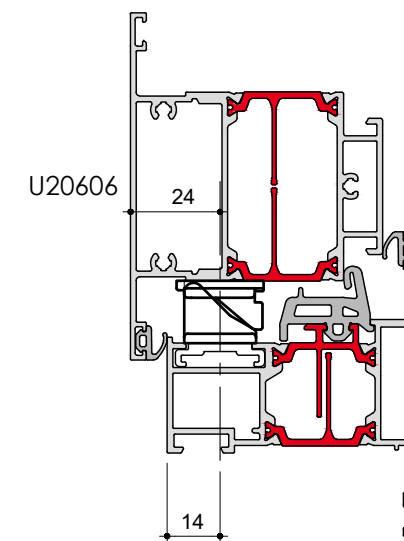
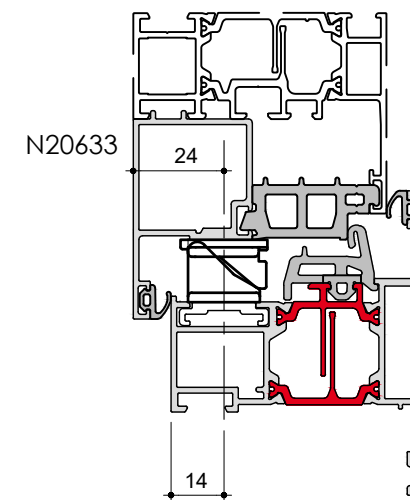
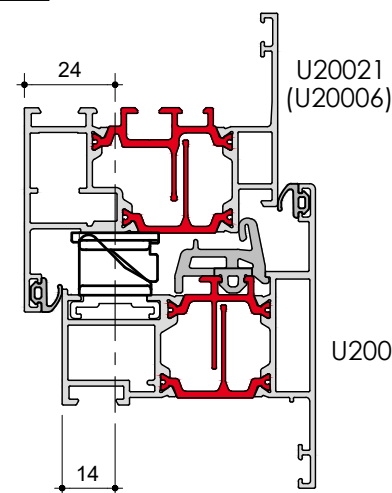
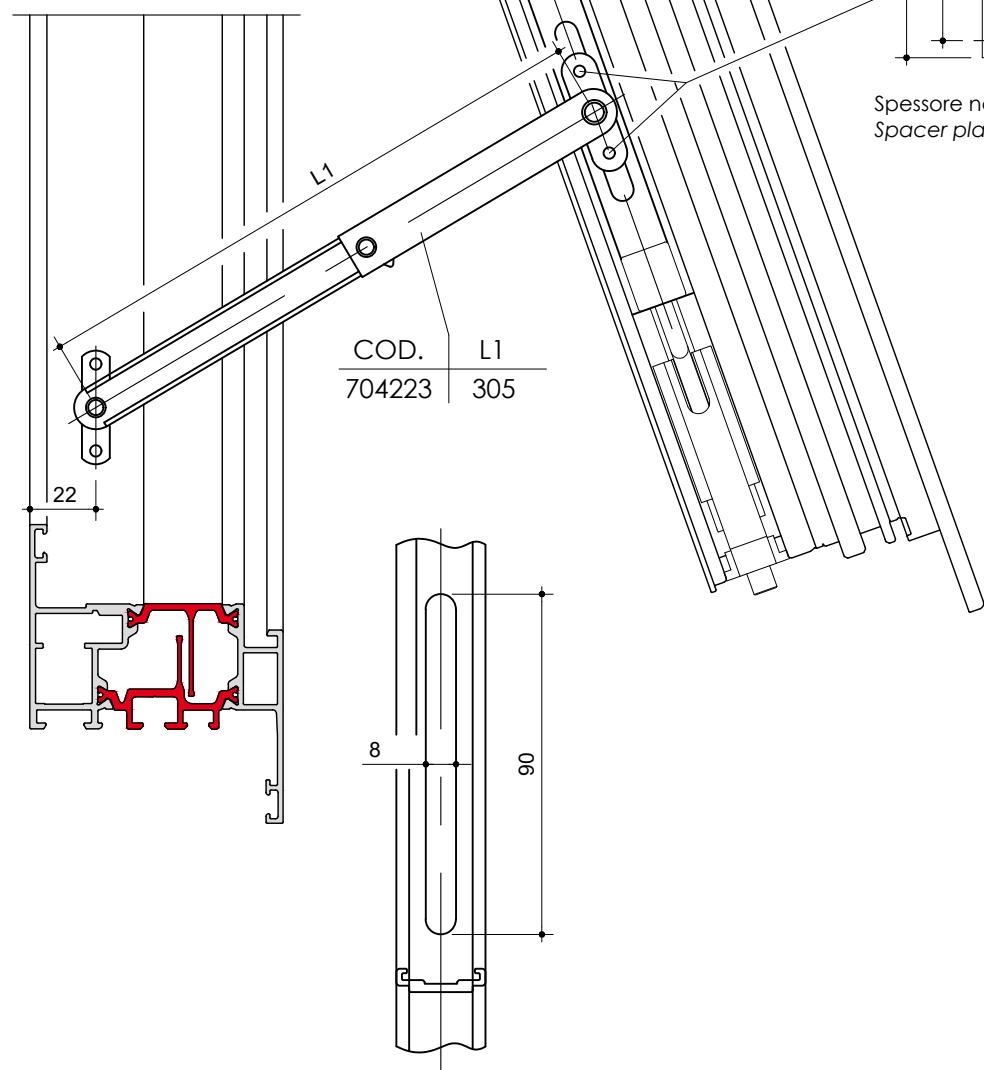
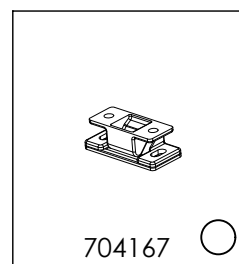

COMPONENTE SU ANTA
 VENT/SASH PART

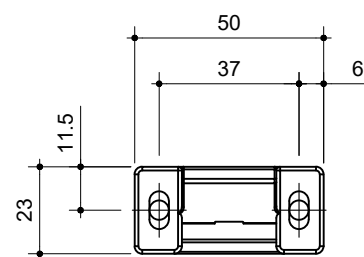

COMPONENTE SU TELAIO
 FRAME PART

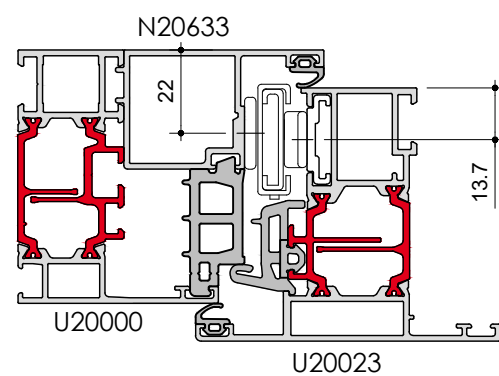
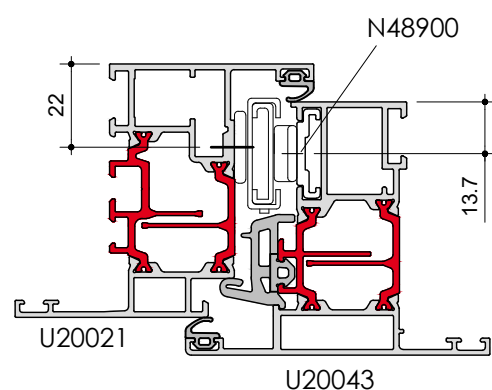

Per determinare il numero di rostri 704167, fare riferimento alle tavole "Dimensionamento finestre" posizionate ad inizio del catalogo. Il singolo rostro va posizionato sul lato superiore in posizione centrale. Nel caso di due rostri, posizionarli tra 100 e 200 mm da entrambi gli angoli (soluzione con compassi) o dalle cerniere.
 La parte regolabile e' posizionata sul telaio, il fissaggio avviene con viti attraverso delle asole. per facilitare la regolazione del componente, allentare le viti di fissaggio e utilizzare le dentellature per trovare la posizione corretta. una volta che e' stato regolato correttamente, stringere le viti.
 La parte fissa e' posizionata sull'anta e fissata con viti attraverso dei fori.

To determine the number of 704167 pull-in blocks, refer to the "Size limits" tables located at the beginning of the catalogue. The single pull-in block must be positioned on the middle of upper transom. Two blocks must be positioned between 100mm to 200mm from each corner (solution with stay arms) or from the hinges.
 The adjustable part is to be positioned on the frame, and the fixings are to be inserted through the slots. fixing screws are to be loosened to allow ease of adjustment, once to correct adjustment has been determined, screws can then be tightened.
 the fixed part is to be positioned on the vent/sash, and fixings are to be inserted through the holes and tightened.

▶
MONTAGGIO CHIUSURE INFISSO A SPORGERE traverso inferiore
PROJECTING WINDOW lower transom LOCKING DEVICES ASSEMBLING DIAGRAM

C67K	C77K	C77K-CS
●		

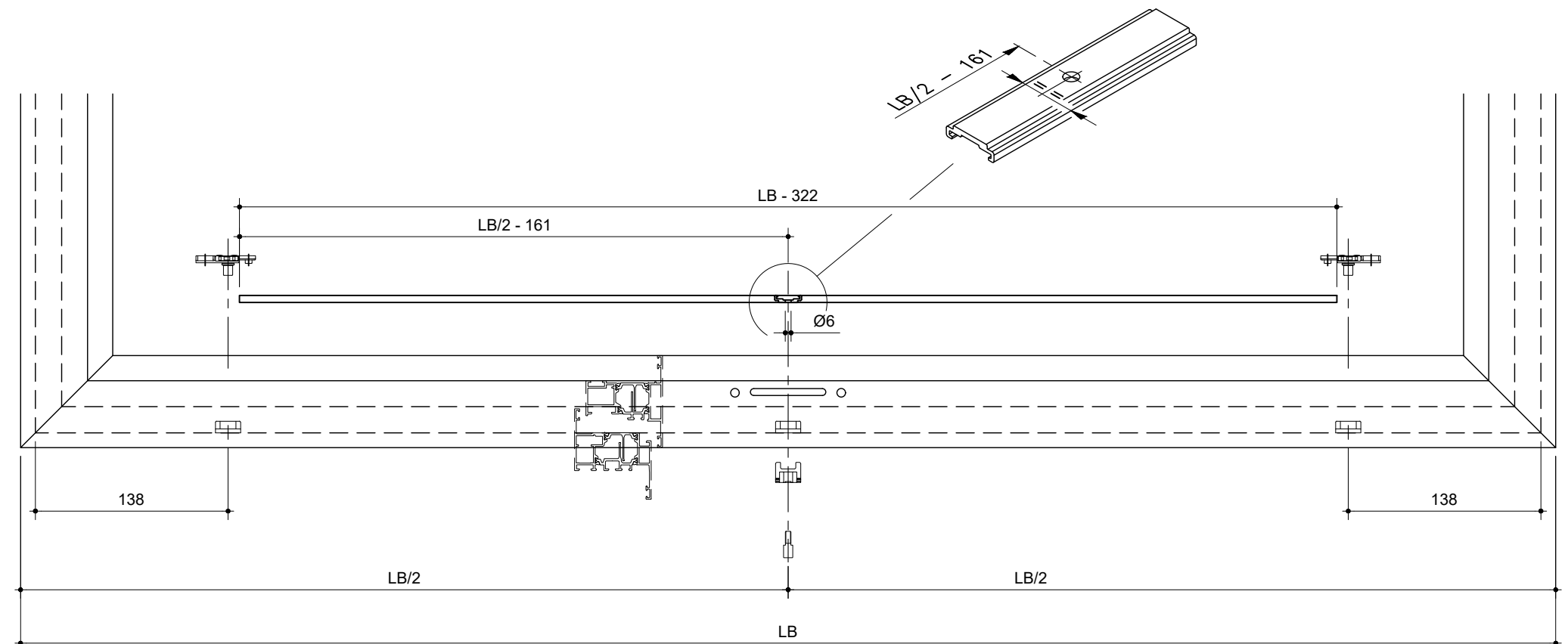
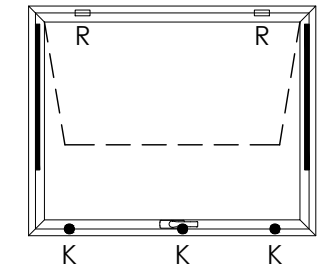
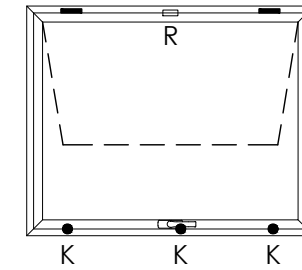
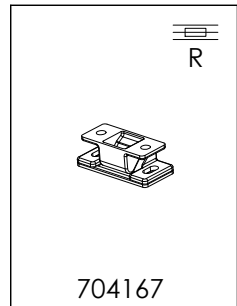
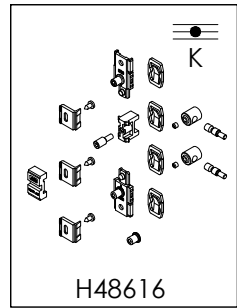
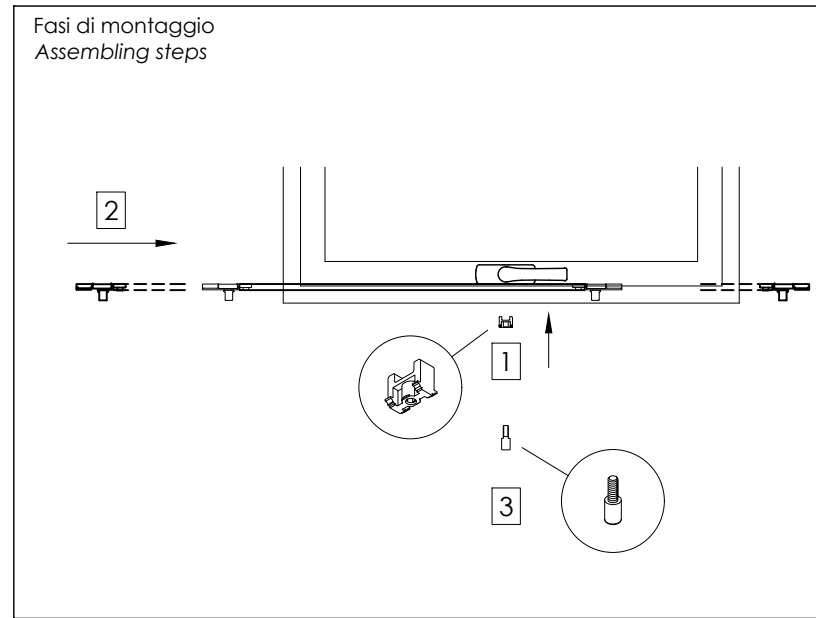
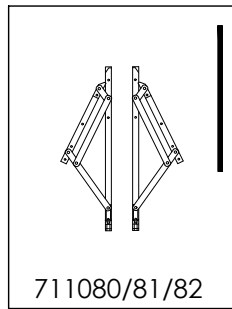
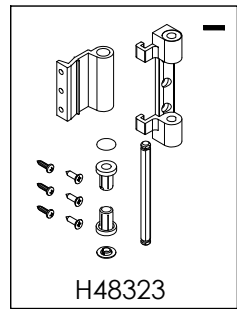
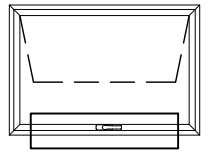

▶ **MONTAGGIO CHIUSURE INFISSO A SPORGERE montanti laterali**
PROJECTING WINDOW side mullion LOCKING DEVICES ASSEMBLING DIAGRAM

C67K	C77K	C77K-CS
●		

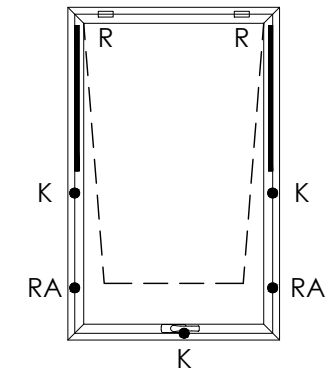
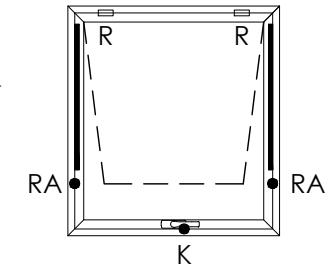
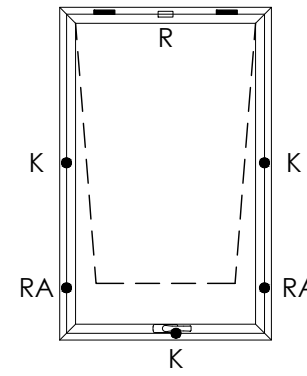
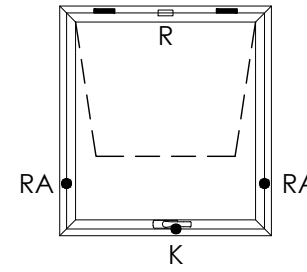
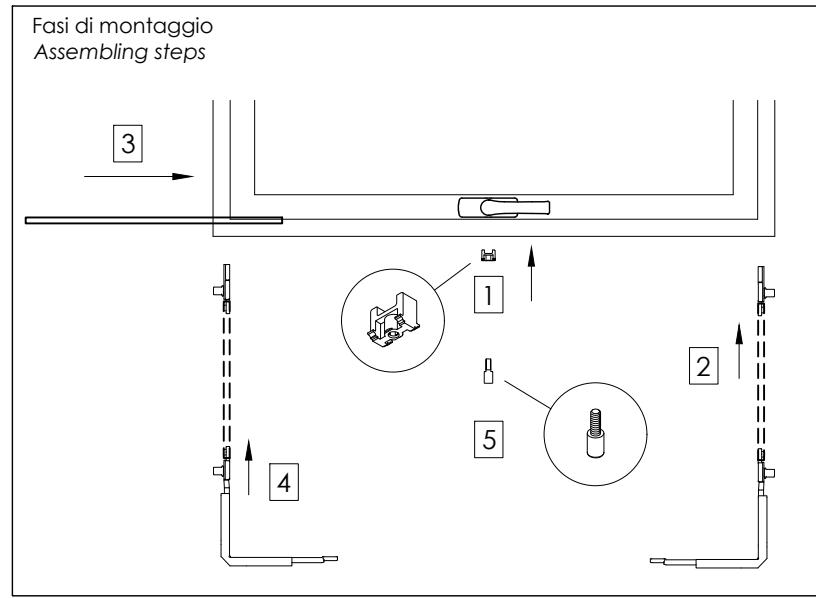
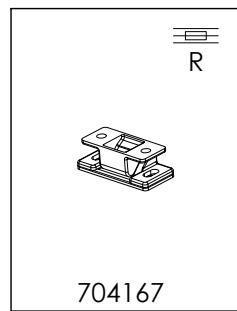
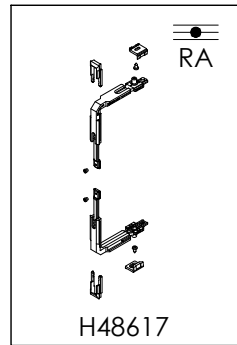
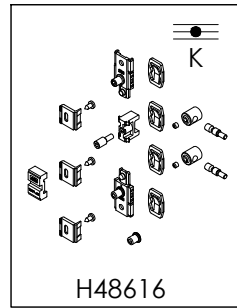
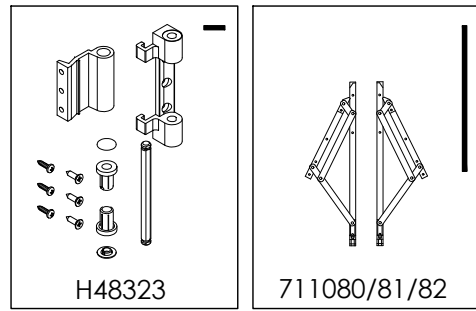
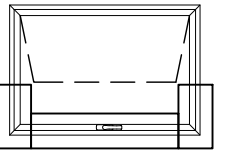

	IC
711081	430
711080	580
711082	700

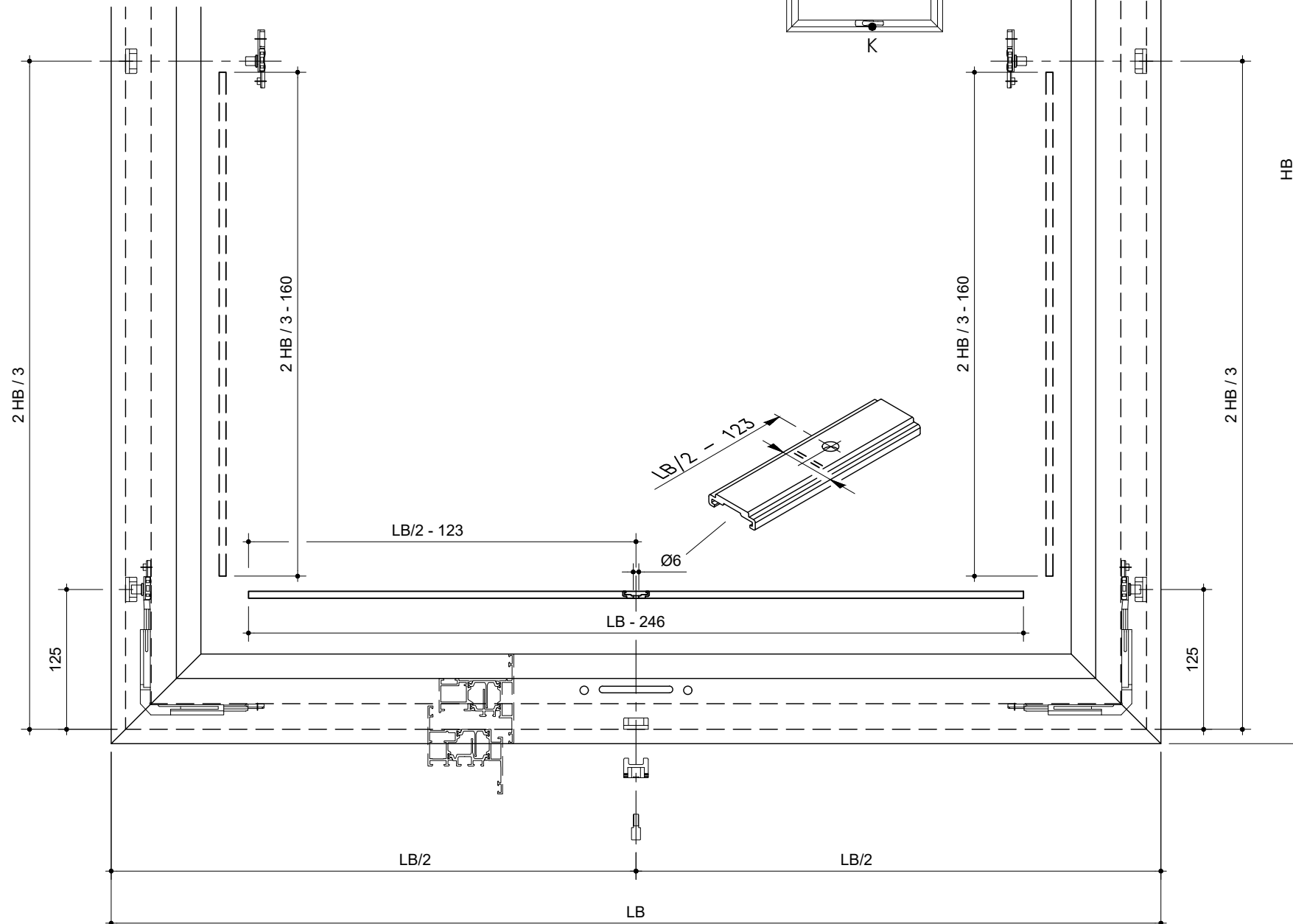

HB

IC

HB - HC - 271

HB - IC - 124

125

▶
MONTAGGIO CHIUSURE INFISSO A SPORGERE traverso superiore
PROJECTING WINDOW upper transom LOCKING DEVICE ASSEMBLING DIAGRAM

C67K	C77K	C77K-CS
●		

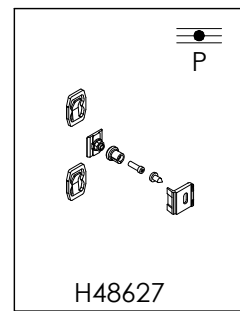
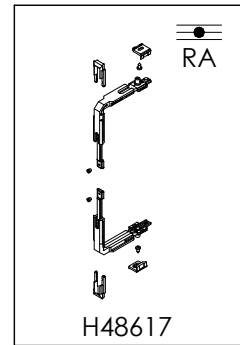
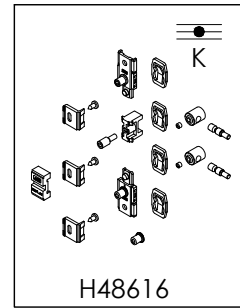
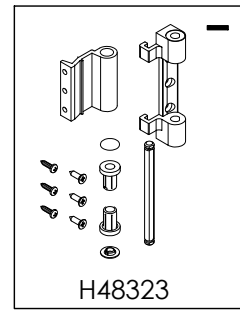
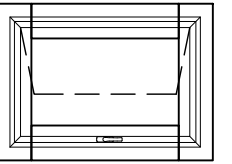

	Pz
H48616	1
H48617	1.5
H48627	3

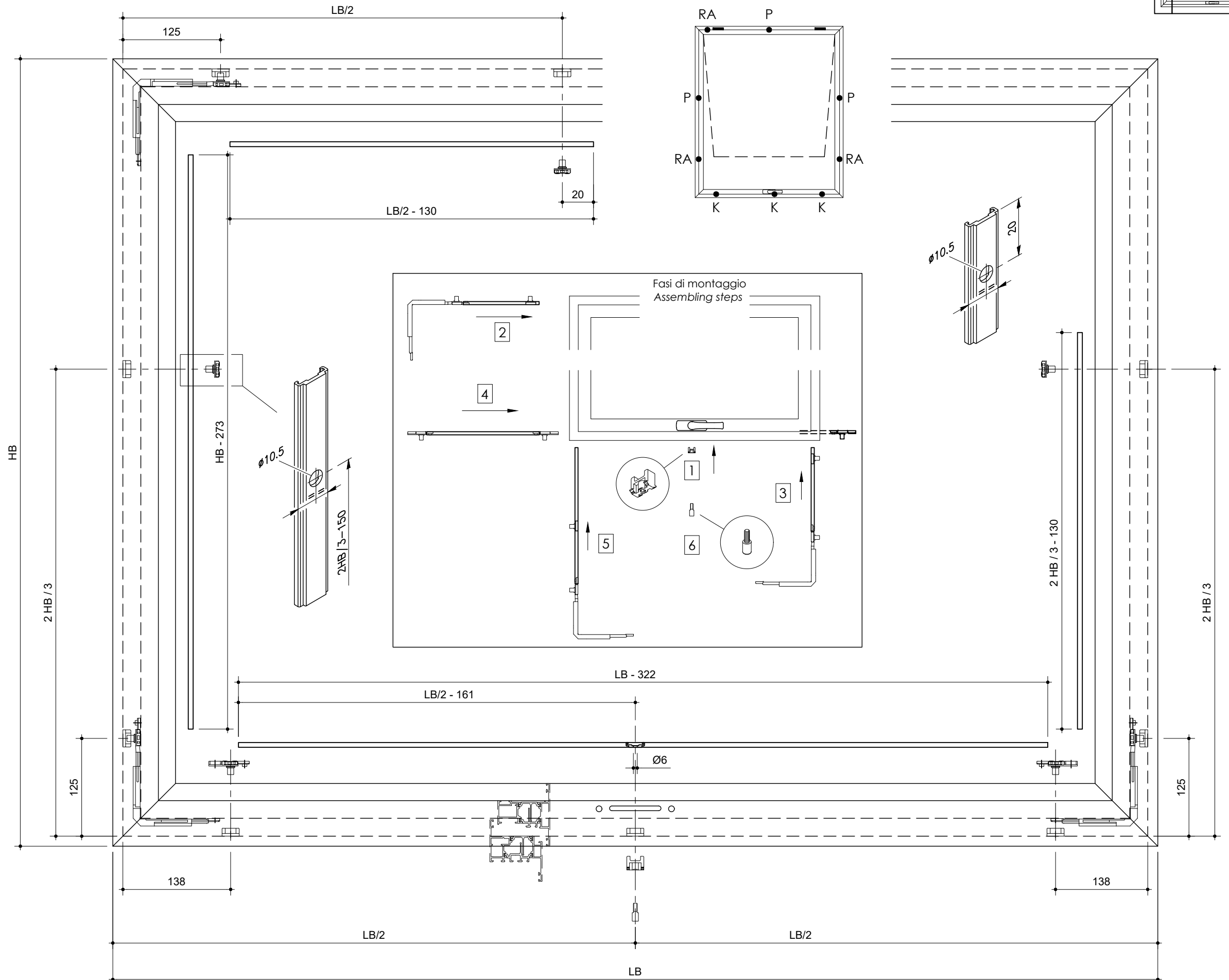

RIEPILOGO FERRAMENTA SPORGERE
PROJECTING WINDOW HARDWARE SUMMARY

C45K-NI	C55K-NI
●	

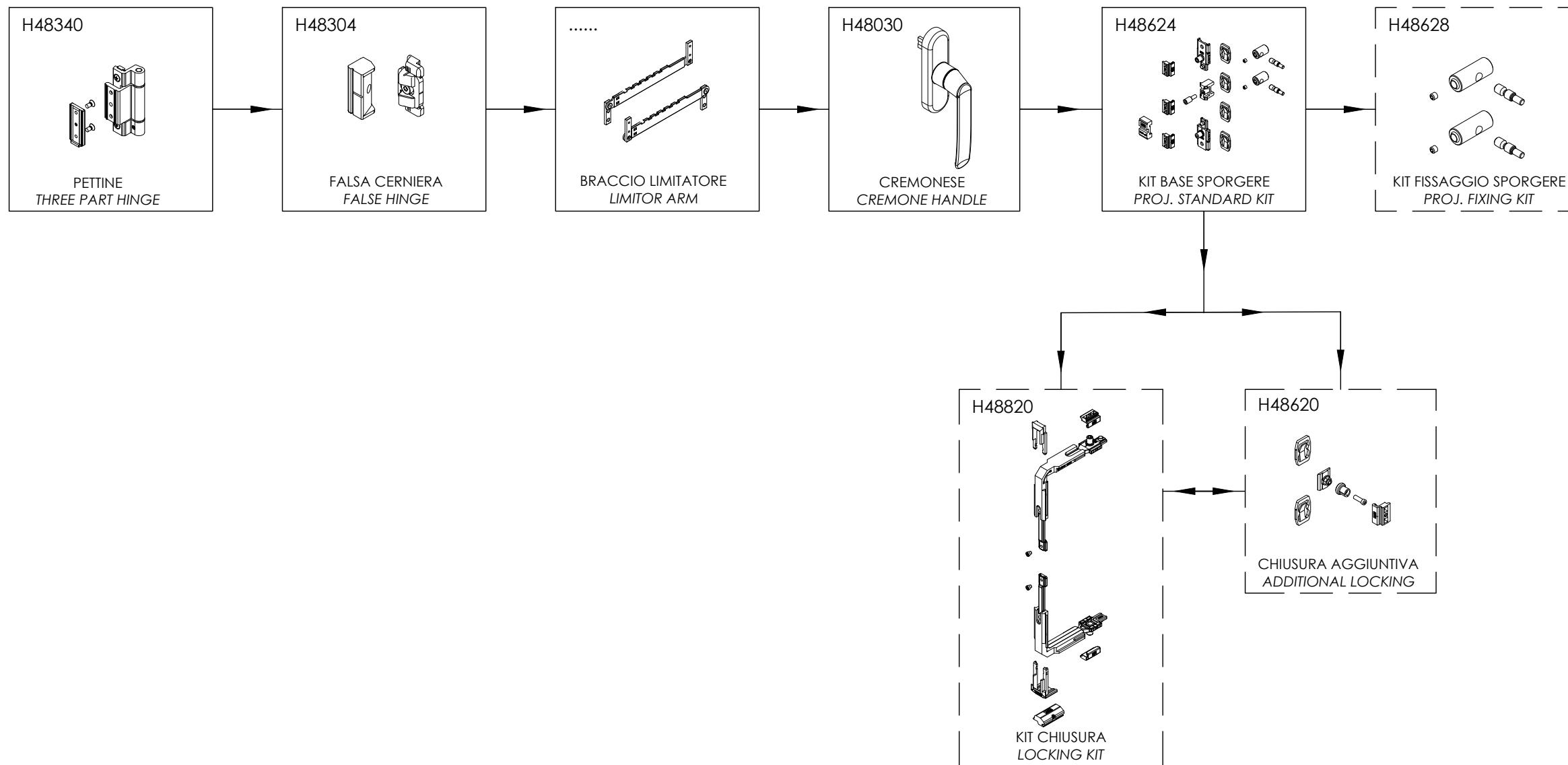
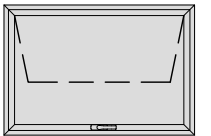

OPZIONALE
OPTIONAL

MONTAGGIO CERNIERA E BRACCETTO LIMITATORE SU FINESTRA A SPORGERE
HINGES AND LIMITOR ARM ON PROJECTING WINDOW ASSEMBLING DIAGRAM

C45K-NI	C55K-NI
●	

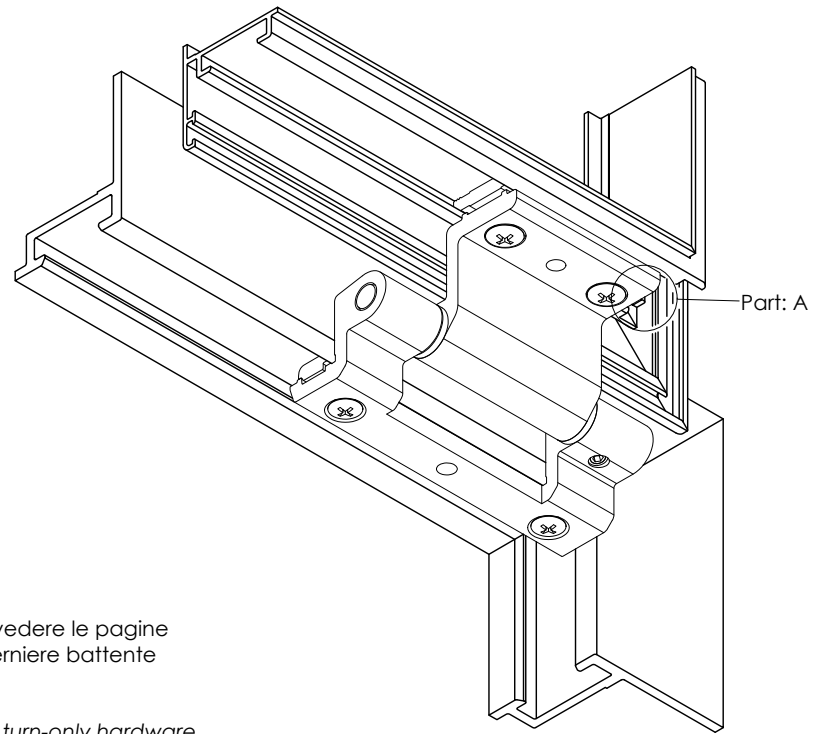
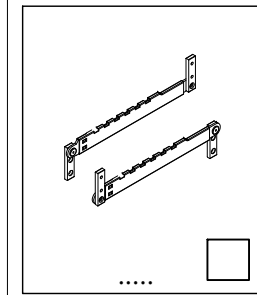
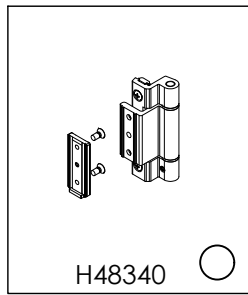
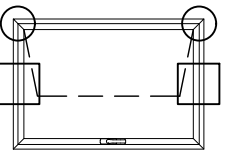

Per il montaggio delle cerniere vedere le pagine dedicate al montaggio delle cerniere battente repertorio 10.4.X

For the hinges assembly see the turn-only hardware dedicated pages 10.4.X

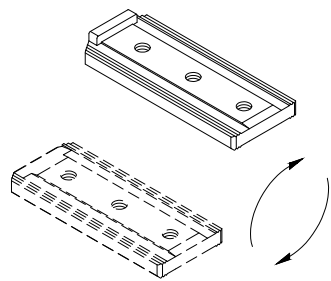
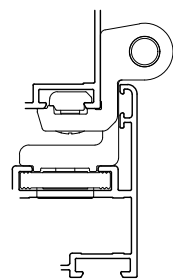

Per il montaggio di cerniere intermedie ruotare la contropiastra con il dentello verso l'esterno

For the assembling of intermediate hinges, rotate the counter-plate with tooth outwards

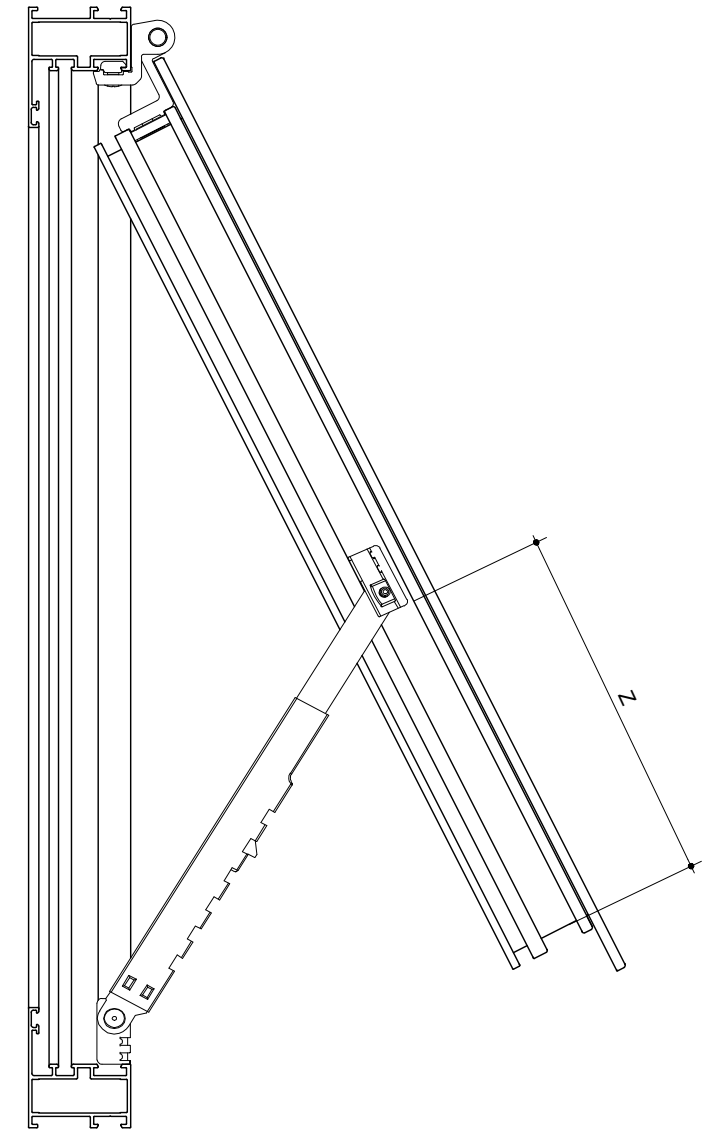
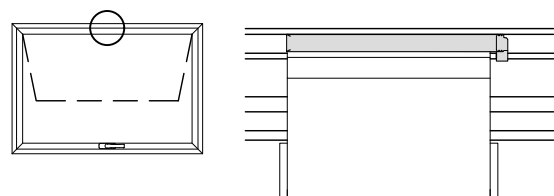

Spessore non fornito
 Spacer not supplied

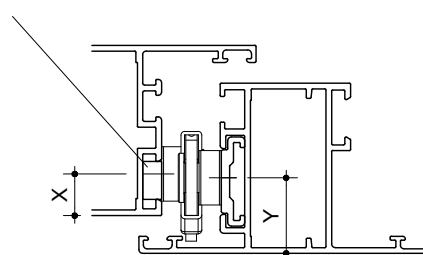

Verificare la portata del braccetto.
 Osservare le indicazioni di montaggio fornite dal produttore (quote X, Y e Z).

Check the load weight of the limitor arm
 Follow the assembling instructions given by the manufacturer (X, Y and Z).

▶ MONTAGGIO CREMONESE E ROSTRO SU FINESTRA A SPORGERE
 CREMONE-HANDLE AND FALSE HINGE ASSEMBLING ON PROJECTING WINDOW

C45K-NI C55K-NI

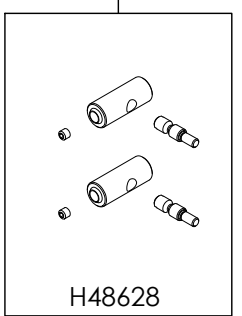
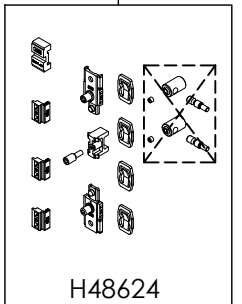
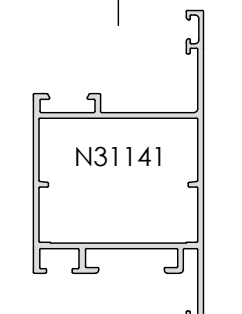
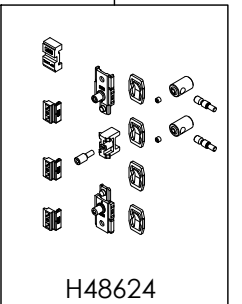
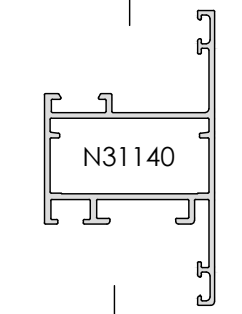
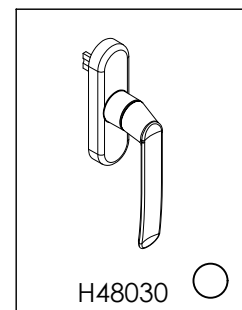
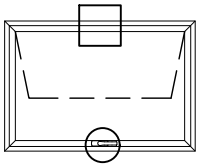

Posizionare il componente prima dell'inserimento dell'asta N48900

Position the component before inserting the N48900 rod

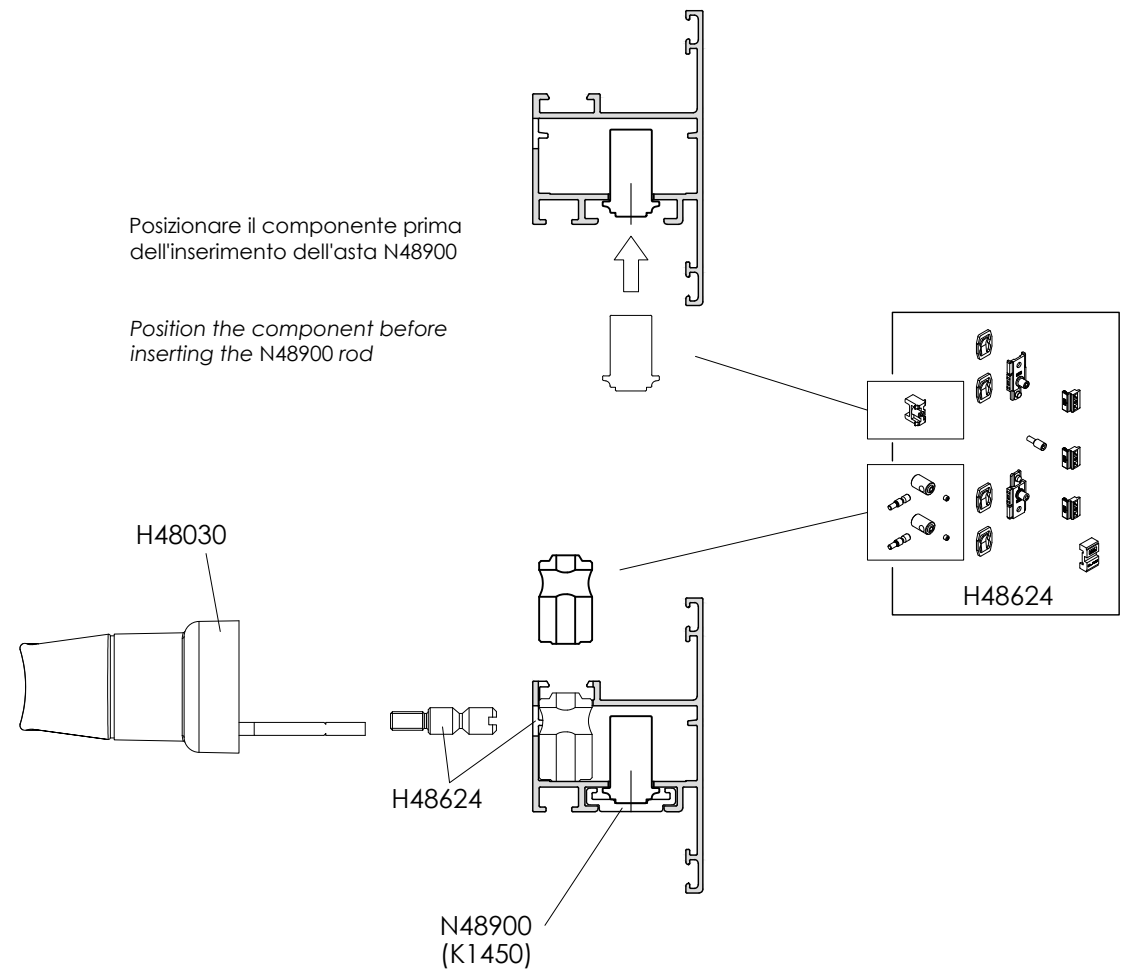

Lavorazione fermavetro da eseguire in zona aggancio cremonese

Glazing bead machining in cremone connection area

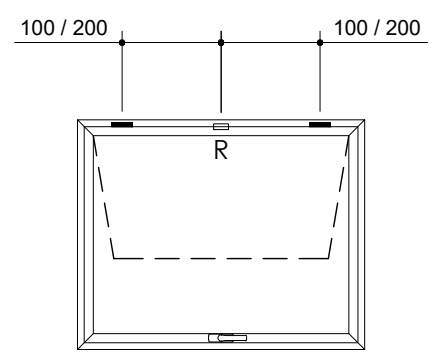
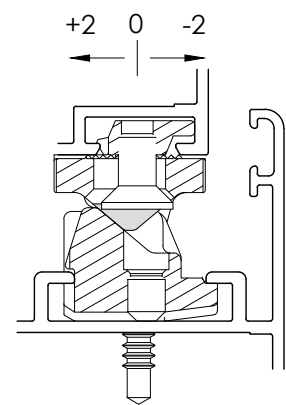
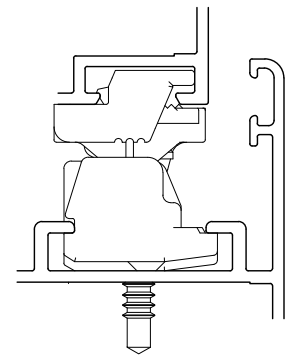
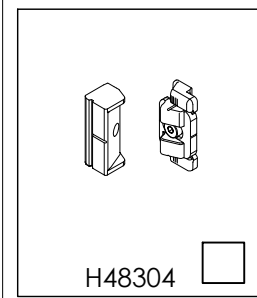
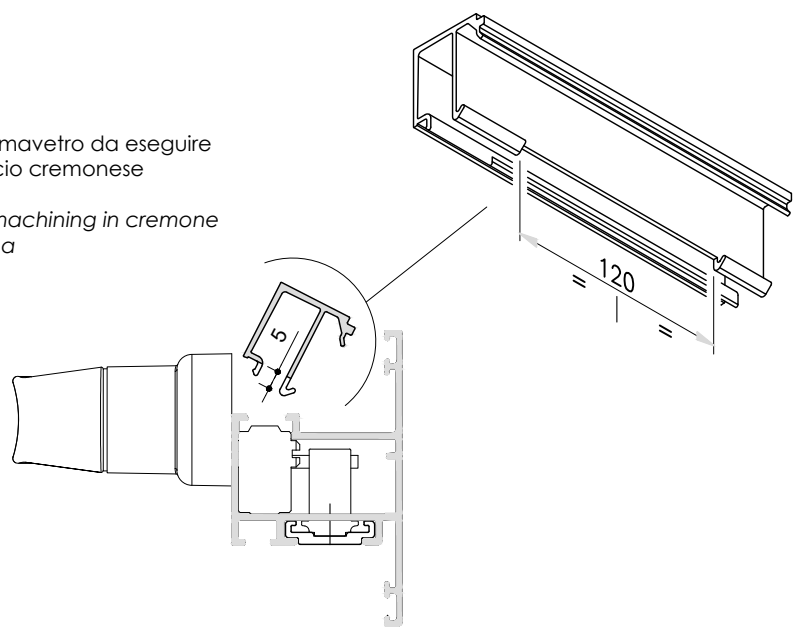

Per determinare il numero di rostri H48304, fare riferimento alle tavole "Dimensionamento finestre" posizionate ad inizio del catalogo. Il singolo rostro (o cerniera supplementare) va posizionato sul lato superiore in posizione centrale. Nel caso di due rostri (o cerniere supplementari), posizionarli tra 100 e 200 mm dalle cerniere principali.

To determine the number of H48304 false hinge, refer to the "Size limits" tables located at the beginning of the catalogue. The single false (or additional) hinge must be positioned on the middle of upper transom. Two false (or additional) hinges must be positioned between 100mm to 200mm from the main hinges.

MONTAGGIO CHIUSURE INFISSO A SPORGERE PROJECTING WINDOW LOCKING DEVICES ASSEMBLING DIAGRAM

C45K-NI C55K-NI

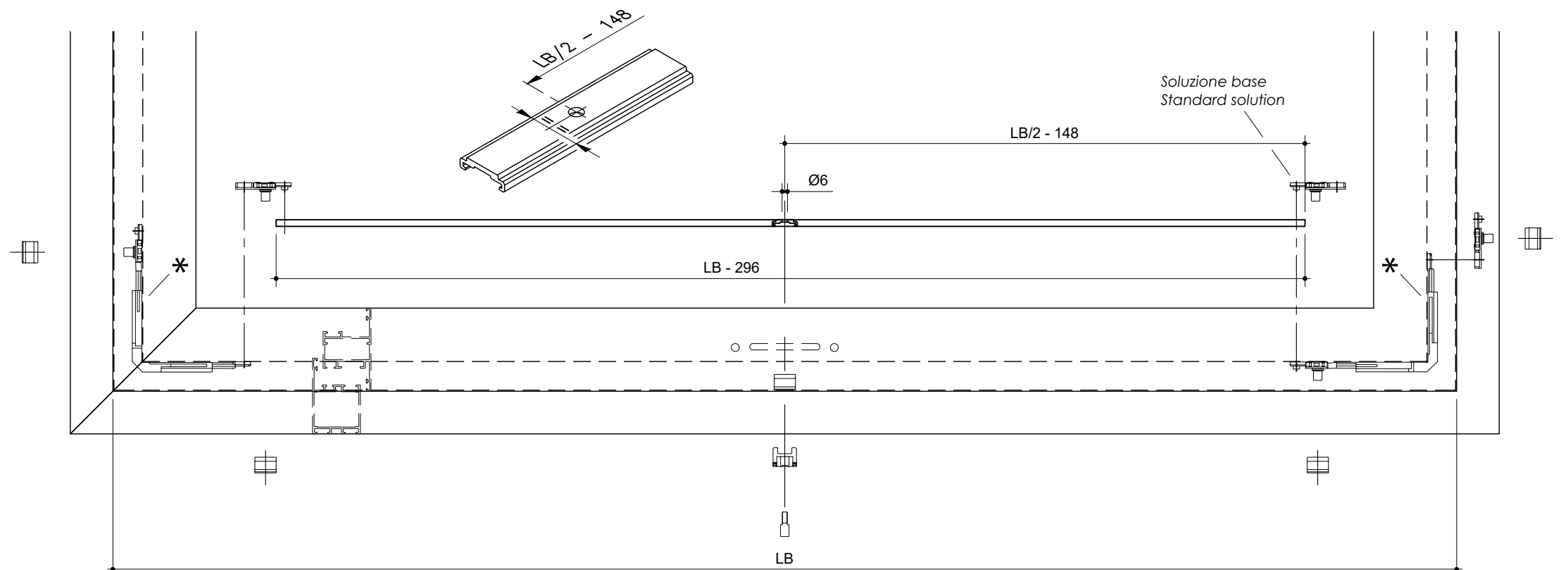
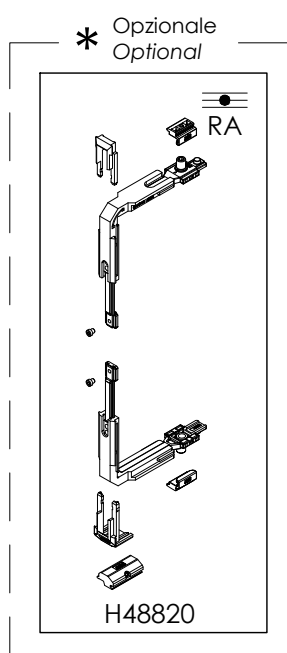
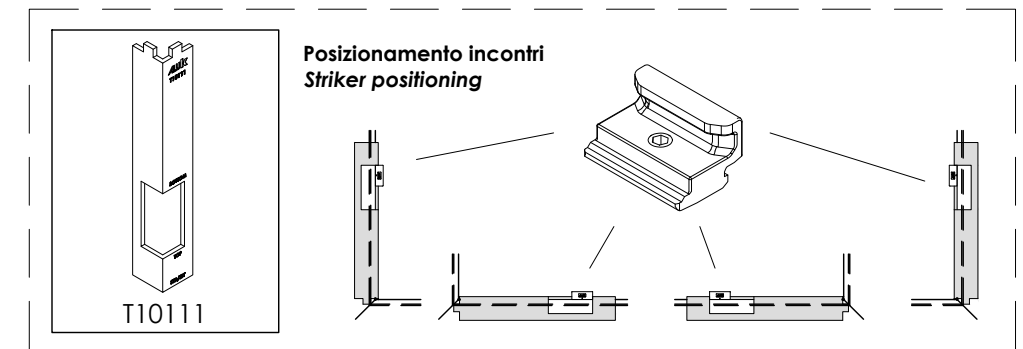
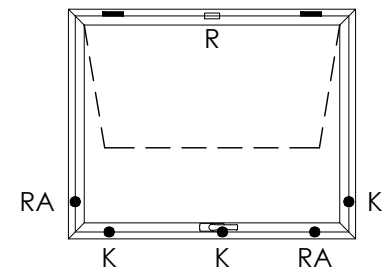
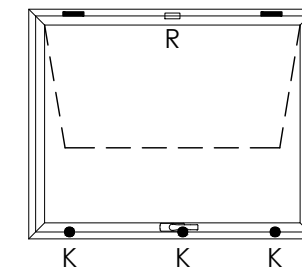
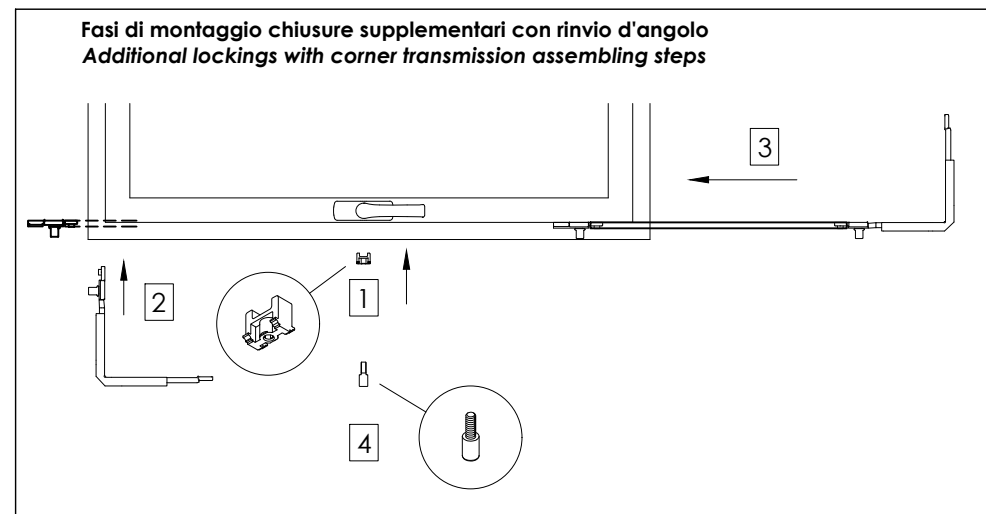
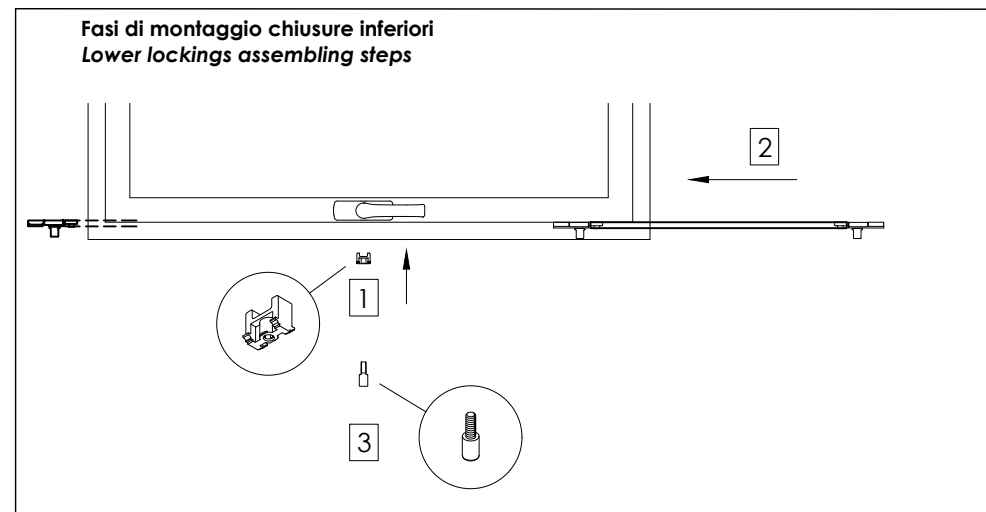
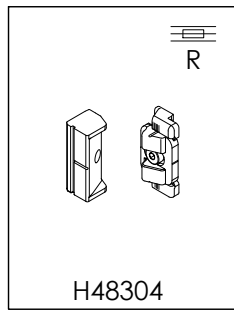
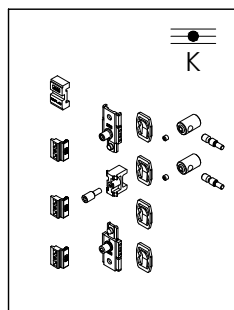
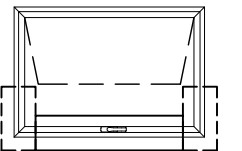

RIEPILOGO FERRAMENTA BILICO
PIVOTING WINDOW HARDWARE SUMMARY

C67K	C77K	C77K-CS
●		

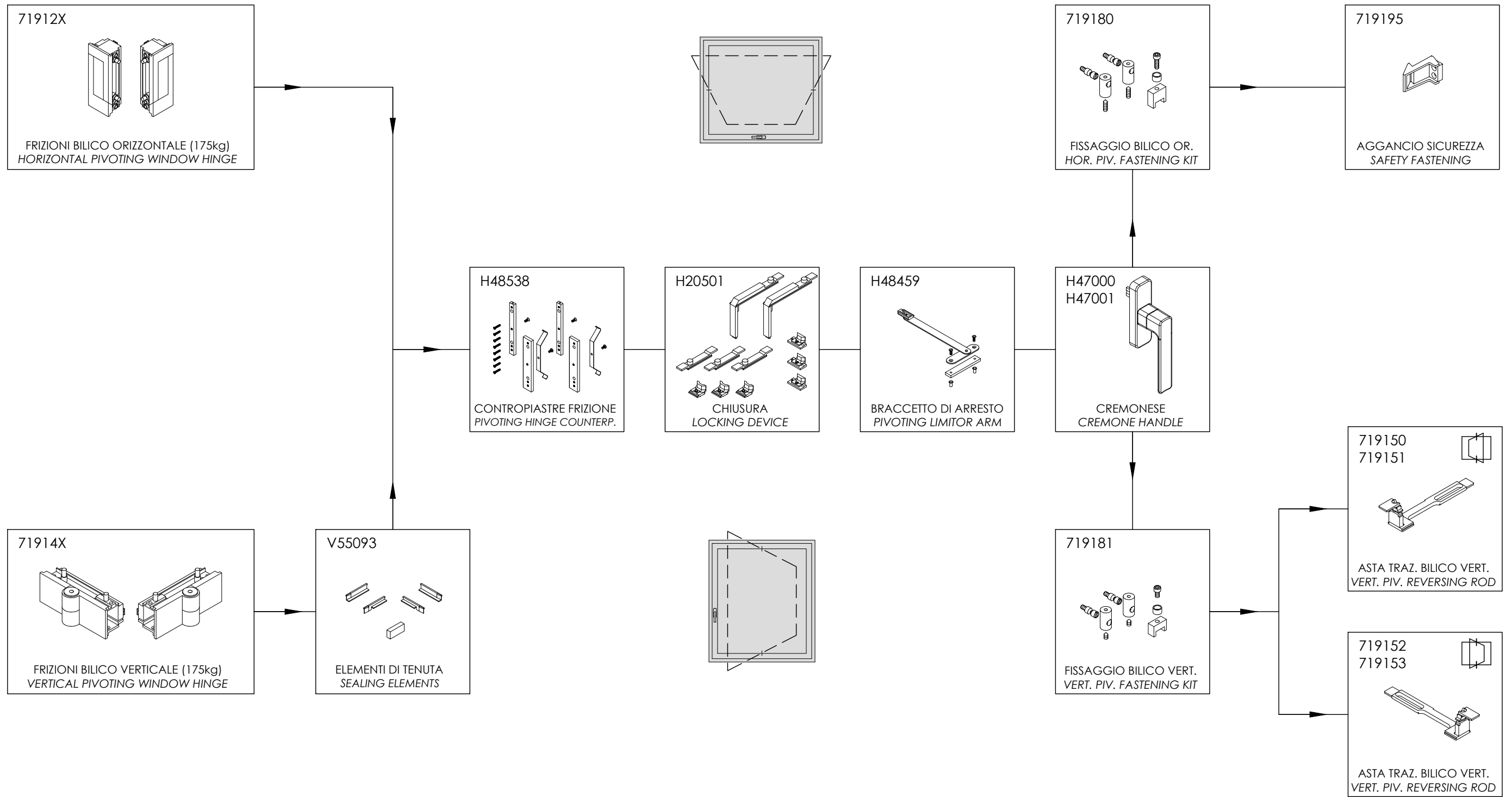

OPZIONALE
OPTIONAL

SCHEMA DI MONTAGGIO FRIZIONI ART. 71912X PER BILICO ORIZZONTALE
 HORIZONTAL PIVOTING WINDOW COD. 71912X HINGES MACHINING DIAGRAM

C67K	C77K	C77K-CS
●		

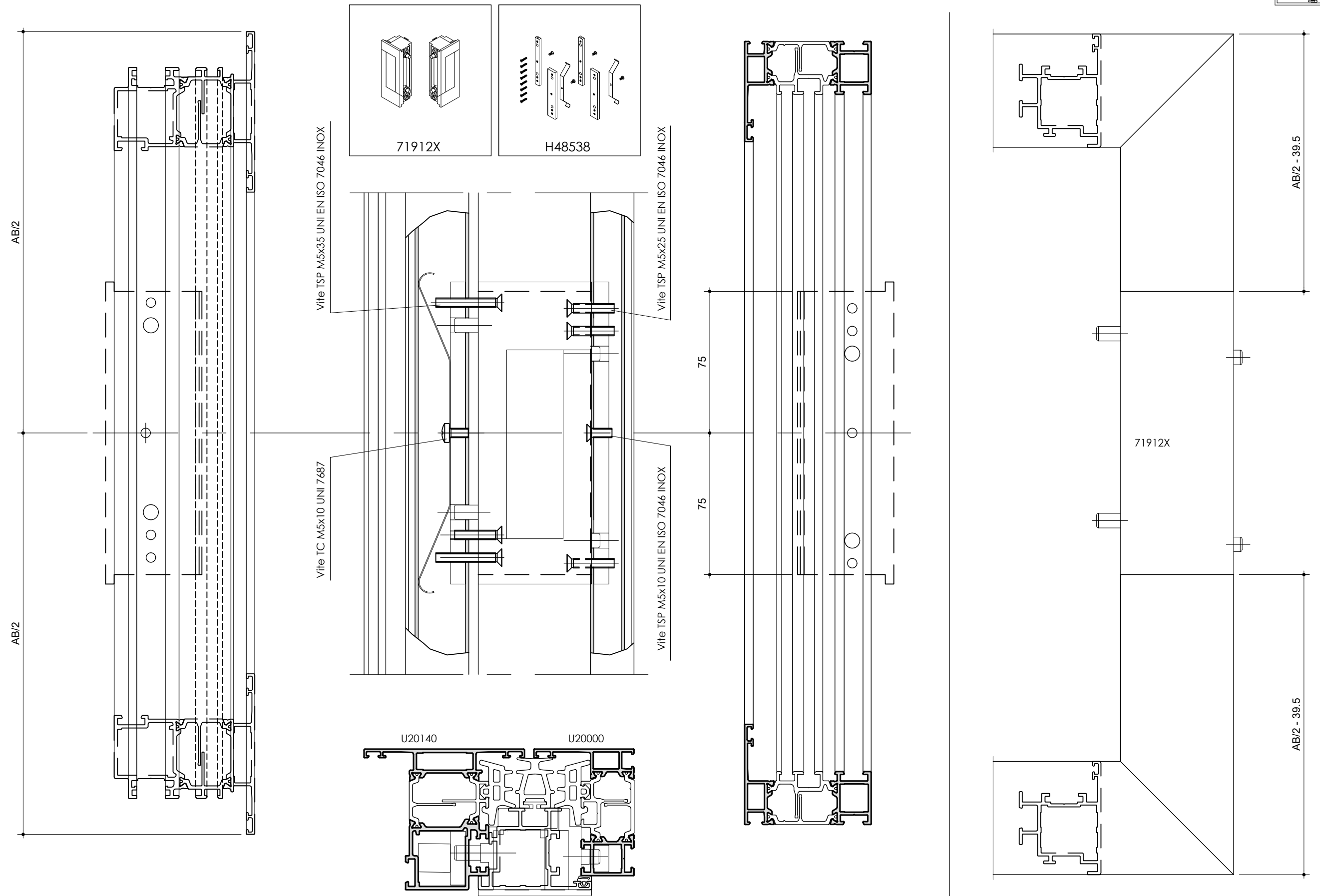
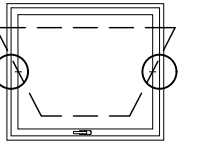

SCHEMA MONTAGGIO CREMONESE CON ACCESSORI PER BILICO ORIZZONTALE
 CREMONE ASSEMBLING DIAGRAM FOR HORIZONTAL PIVOTING WINDOW HARDWARE

C67K	C77K	C77K-CS
●		

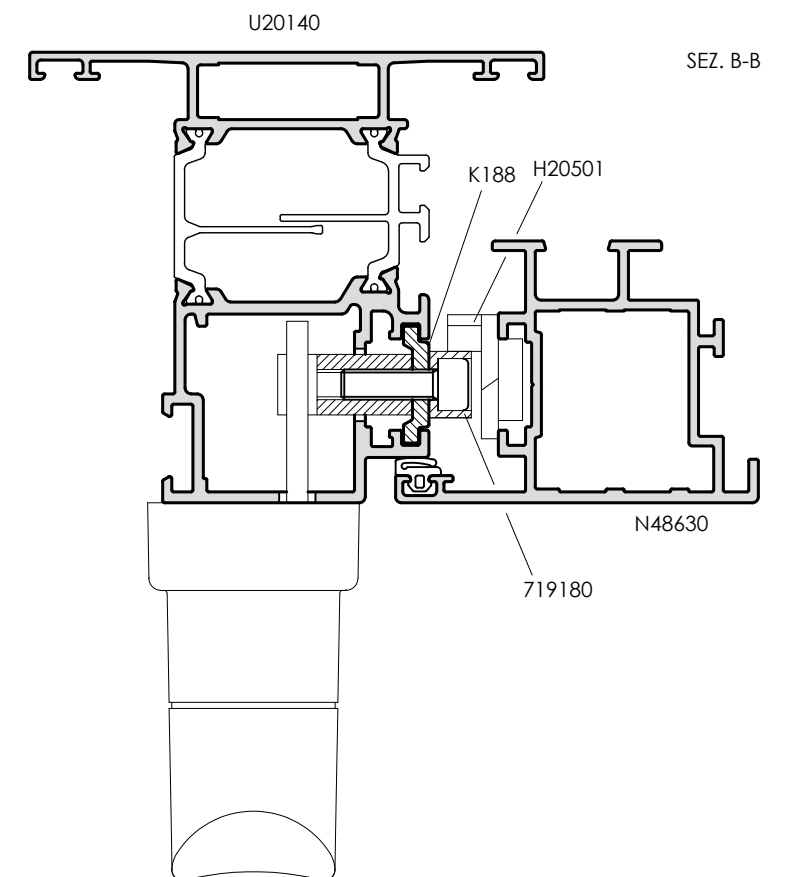
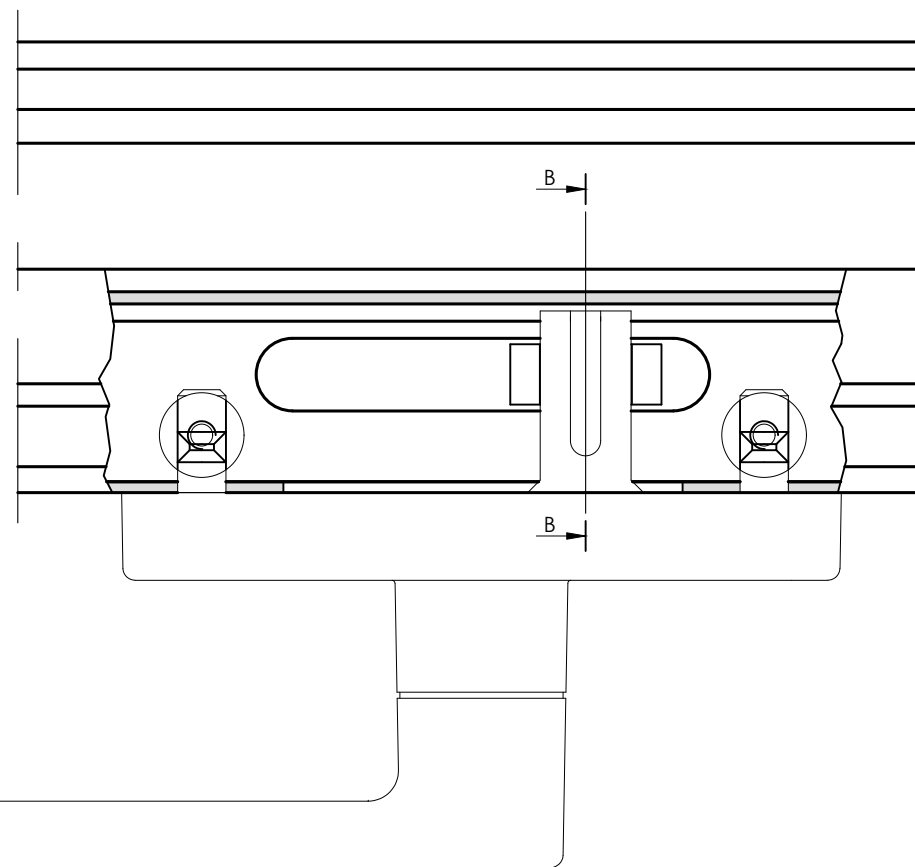
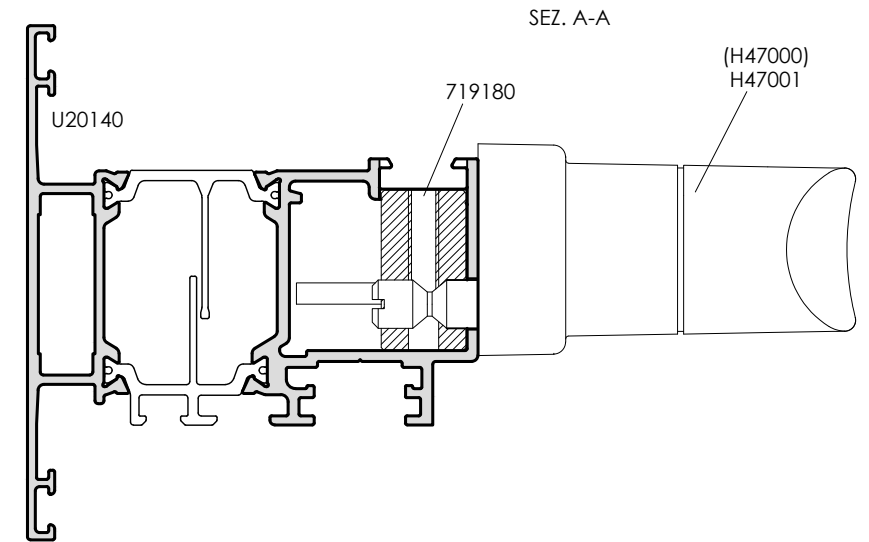
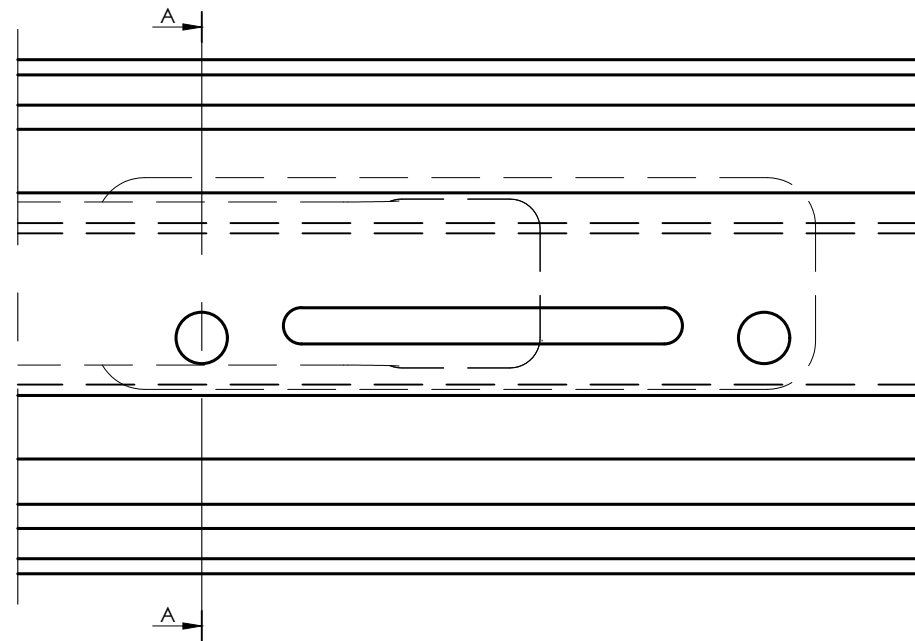
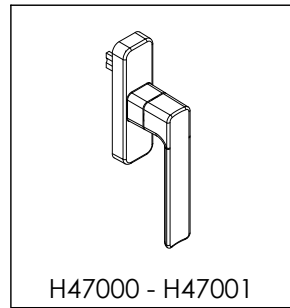
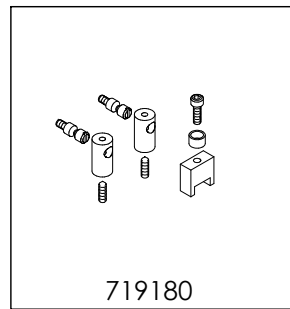
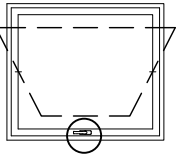

MONTAGGIO DISPOSITIVI DI SICUREZZA PER BILICO ORIZZONTALE E REGOLAZIONE DELLE FRIZIONI HORIZONTAL PIVOTING WINDOW SAFETY FASTENING ASSEMBLING AND PIVOT ADJUSTMENT

C67K	C77K	C77K-CS
●		

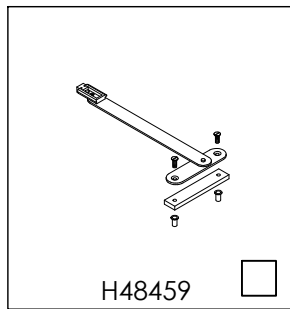
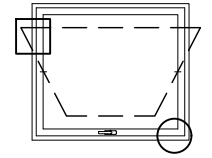

MONTAGGIO BRACCETTO LIMITATORE
LIMITOR ARM ASSEMBLING

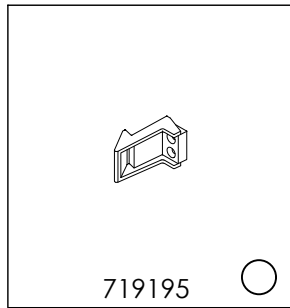

Fine corsa regolabile
Adjustable stroke-end

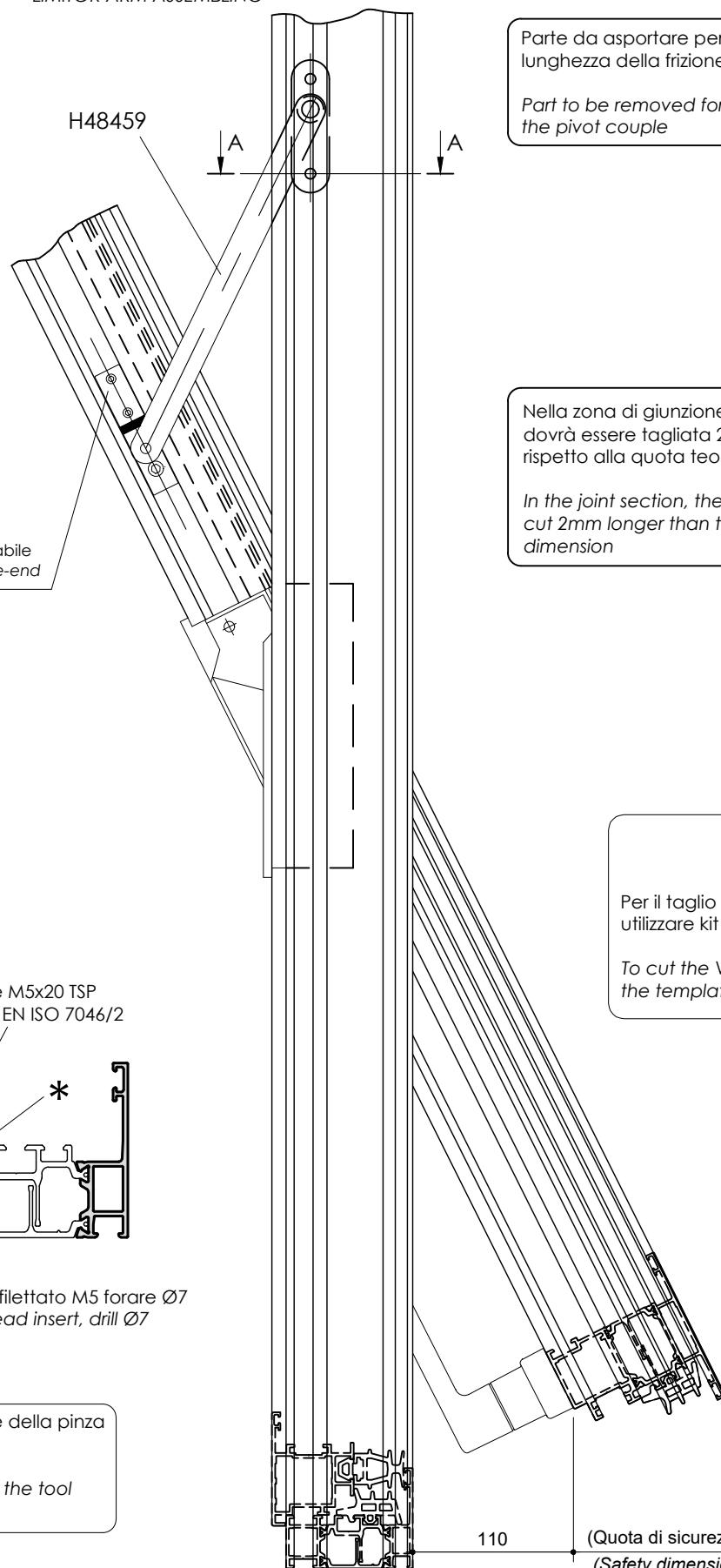
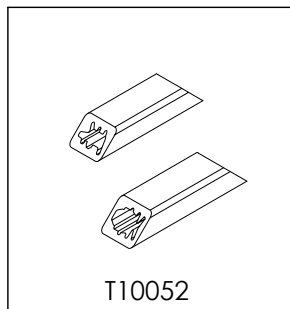

Parte da asportare per tutta la lunghezza della frizione
Part to be removed for the full extent of the pivot couple

Nella zona di giunzione la guarnizione dovrà essere tagliata 2mm più lunga rispetto alla quota teorica
In the joint section, the gasket shall be cut 2mm longer than the standard dimension

Per il taglio delle guarnizioni V02014 e V03025 utilizzare kit dime T10052
To cut the V02014 and V03025 gaskets use the template kit T10052

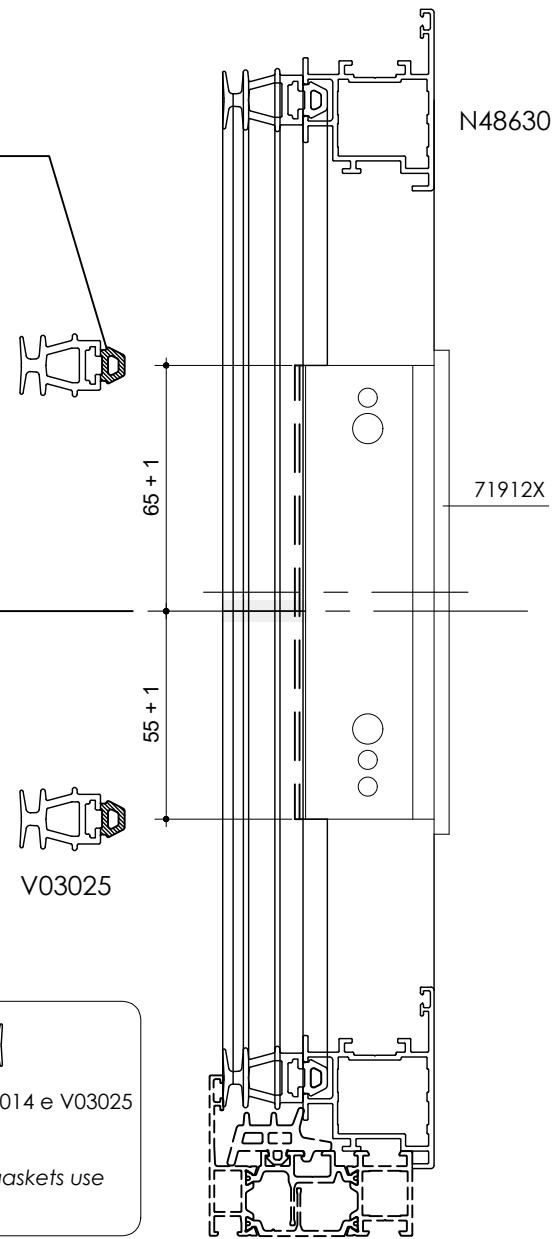

MONTAGGIO FERMO PER BLOCCAGGIO ANTA IN POSIZIONE 180° PER PULIZIA VETRO
ASSEMBLY OF THE SAFETY FASTENING WITH SASH IN 180° POSITION FOR WINDOW CLEANING

ASSEMBLY OF THE SAFETY FASTENING WITH SASH IN 180° POSITION FOR WINDOW CLEANING

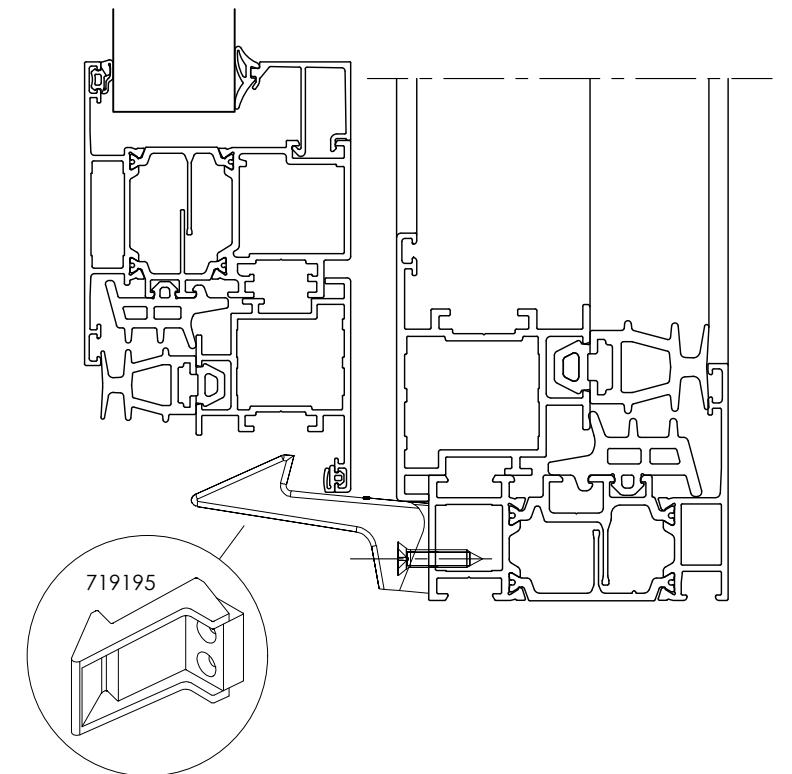

Vite M5x20 TSP
UNI EN ISO 7046/2

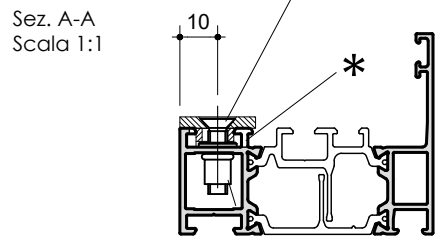

Inserto filettato M5 forare Ø7
M5 thread insert, drill Ø7

Asportazione in funzione della pinza tiraviti a disposizione
* Removal depending on the tool available

REGOLAZIONE FRIZIONE art. 71912X
HINGE ADJUSTMENT art. 71912X

Regolazione della resistenza alla rotazione del primo perno (per apertura anta fino a 54°) tramite dado esagonale con chiave da 17. Serrare i dadi con la medesima coppia.
Friction adjusting on 1st pivoting point (sash opening up to 54°) by means of hexagonal nut with key size 17. Tighten the nuts on both hinges equally.

Regolazione della resistenza alla rotazione del secondo perno (apertura anta 54°-180°) tramite vite.
Friction adjustment on 2nd pivoting point (sash opening 54°-180°) using a screw driver.

Montaggio e smontaggio dell'anta in apertura 180° allentando la vite (la vite è assicurata contro lo sfilamento).
Hinging and unhinging of sash in 180° position by loosening the brake nipple screw (screw is secured against falling out).

SCHEMA DI MONTAGGIO ACCESSORI PER BILICO ORIZZONTALE
 HORIZONTAL PIVOTING WINDOW HARDWARE ASSEMBLING DIAGRAM

C67K	C77K	C77K-CS
●		

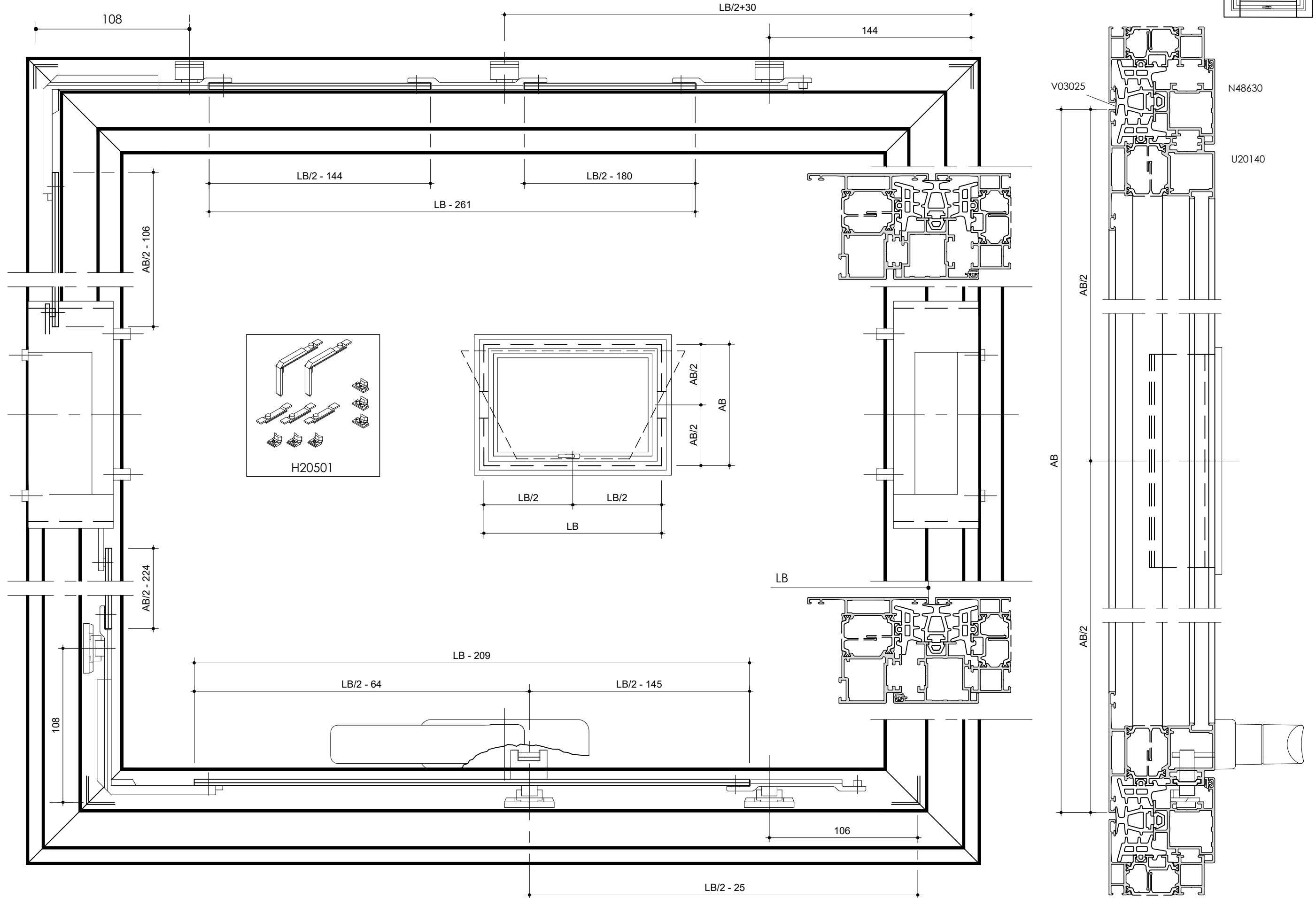
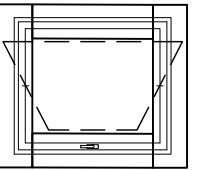

SCHEMA DI MONTAGGIO FRIZIONI ART. 71914X PER BILICO VERTICALE
 VERTICAL PIVOTING WINDOW COD. 71914X HINGES MACHINING DIAGRAM

C67K	C77K	C77K-CS
●		

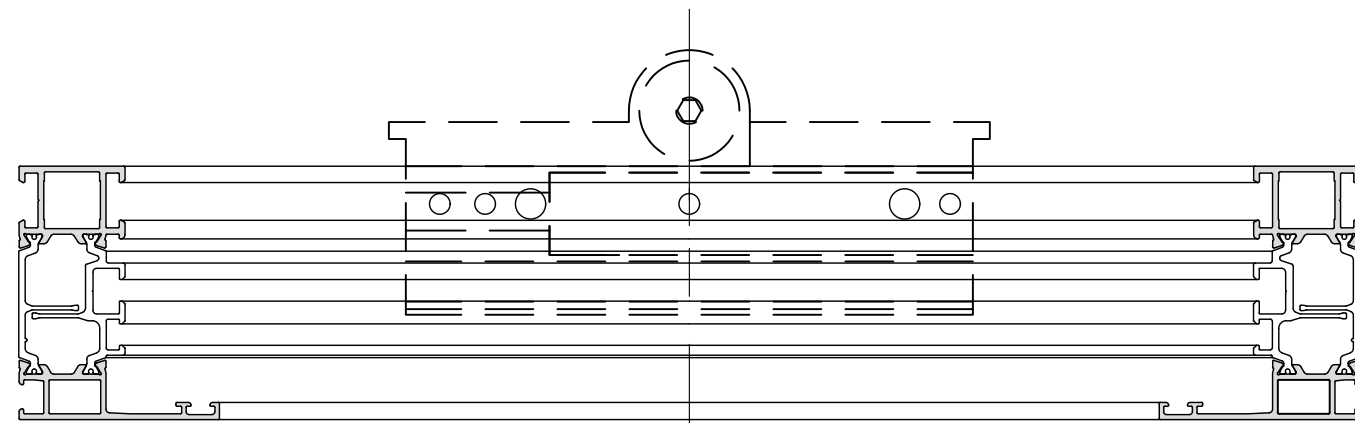
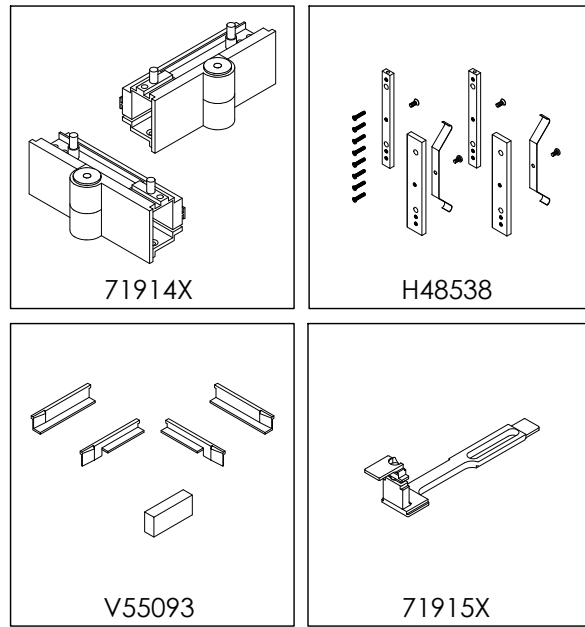
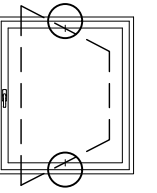

Vite TSP M5x25 UNI EN ISO 7046 INOX Vite TSP M5x10 UNI EN ISO 7046 INOX

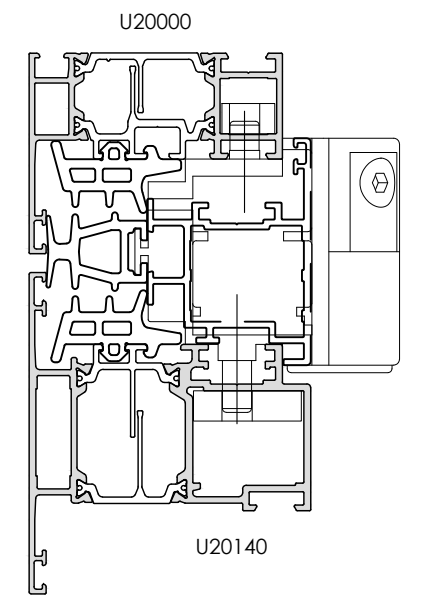
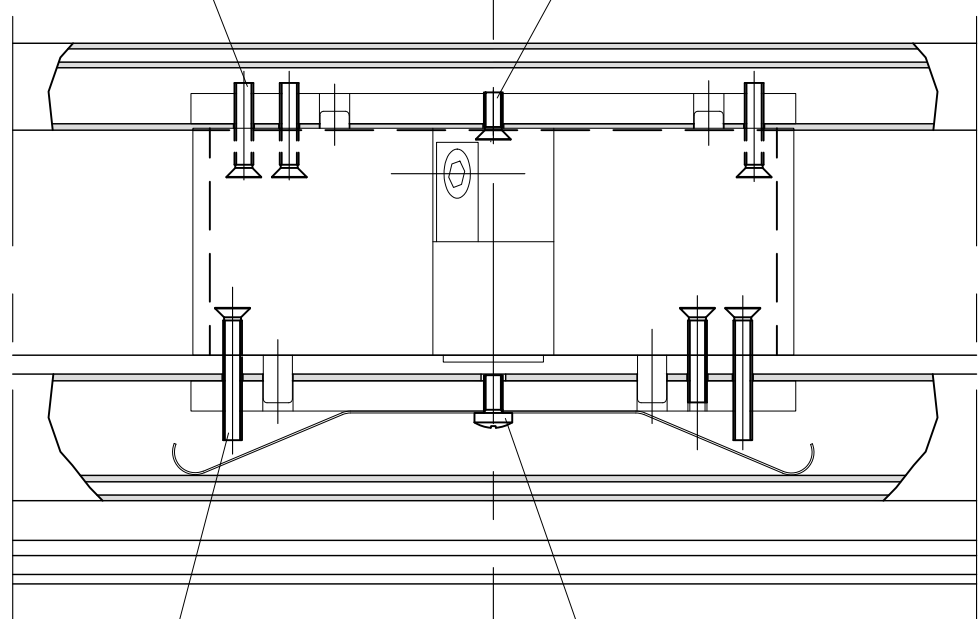

Vite TSP M5x35 UNI EN ISO 7046 INOX Vite TC UNI 7687 M5x10

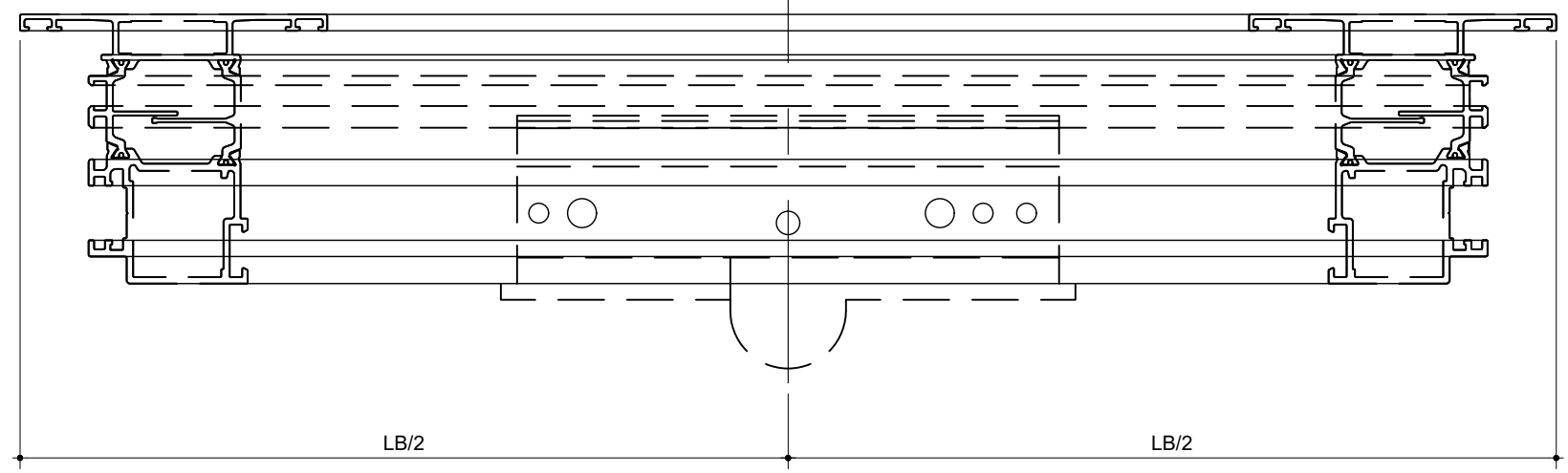

LB/2 LB/2

MONTAGGIO ELEMENTI DI TENUTA KIT V55093
 SEALING ELEMENTS KIT V55093 ASSEMBLING

Da montare unicamente su frizione inferiore
 To be installed on the bottom pivot only

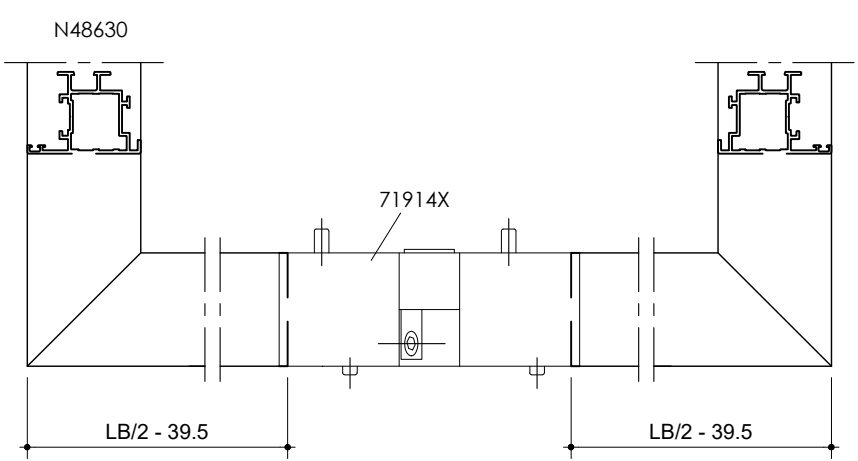
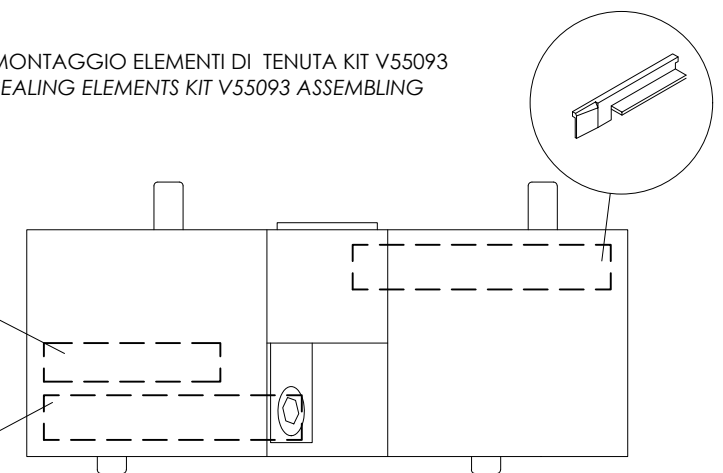
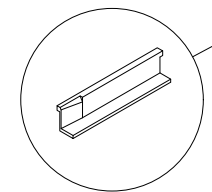

N48630 71914X

LB/2 - 39.5 LB/2 - 39.5

SCHEMA MONTAGGIO CREMONESE CON ACCESSORI PER BILICO VERTICALE
 CREMONE ASSEMBLING DIAGRAM FOR VERTICAL PIVOTING WINDOW HARDWARE

C67K	C77K	C77K-CS
●		

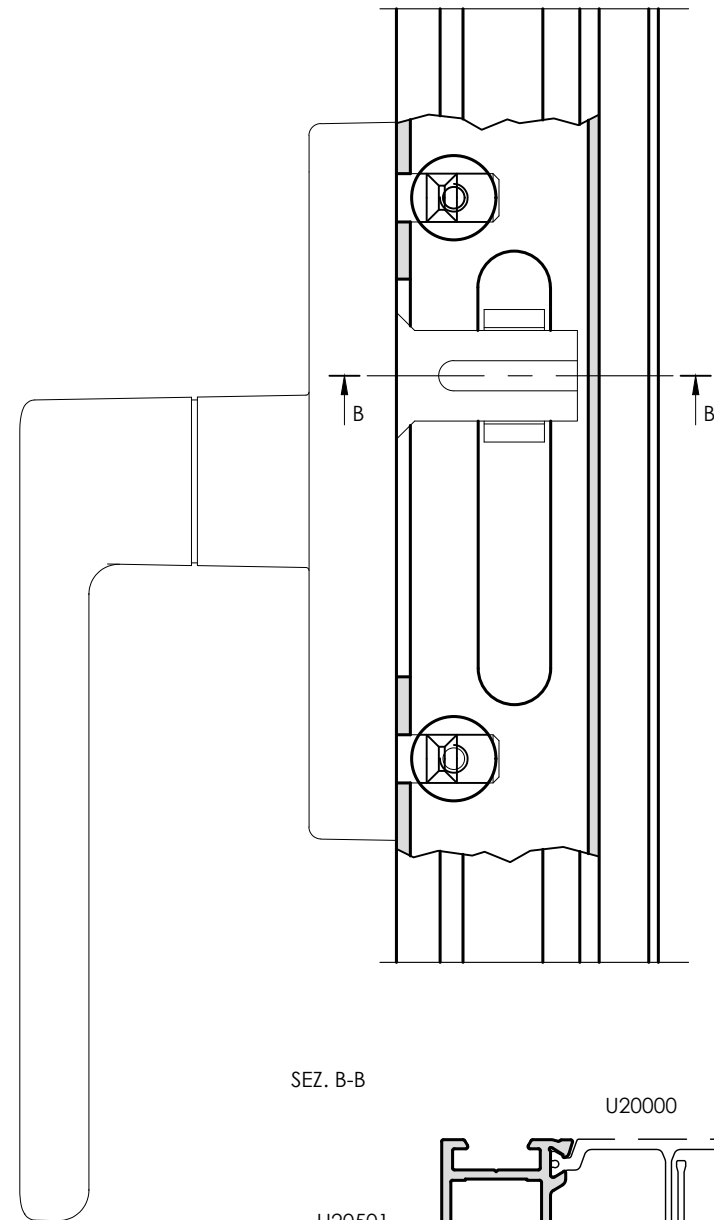
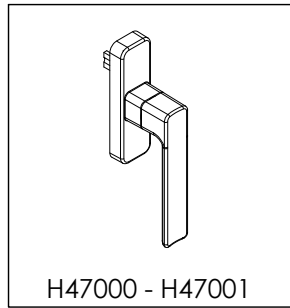
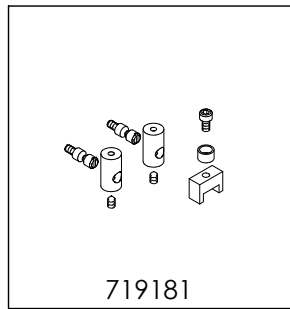
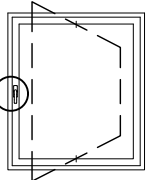

SEZ. B-B

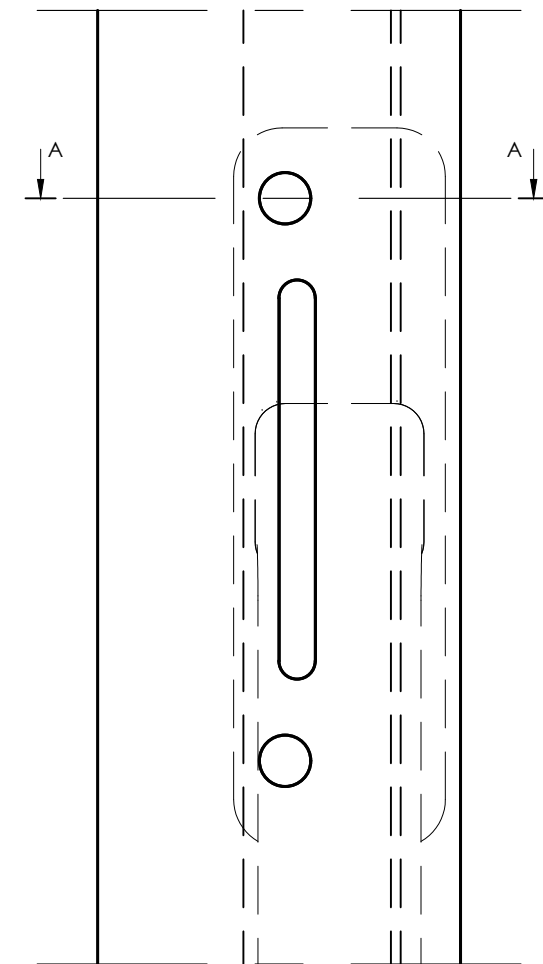
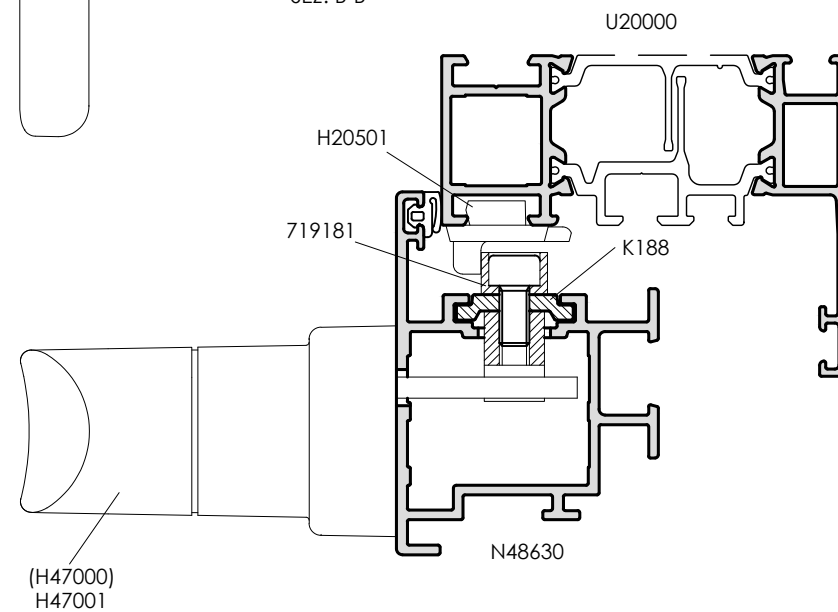

SEZ. A-A

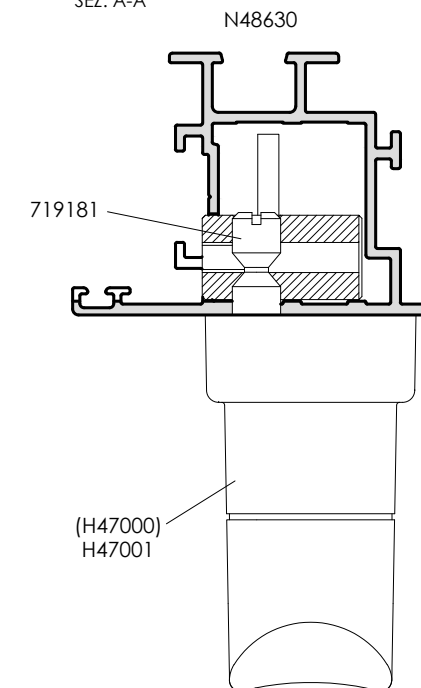

▶ MONTAGGIO DISPOSITIVI DI SICUREZZA PER BILICO VERTICALE E REGOLAZIONE DELLE FRIZIONI
 VERTICAL PIVOTING WINDOW SAFETY FASTENING ASSEMBLING AND PIVOT ADJUSTMENT

C67K	C77K	C77K-CS
●		

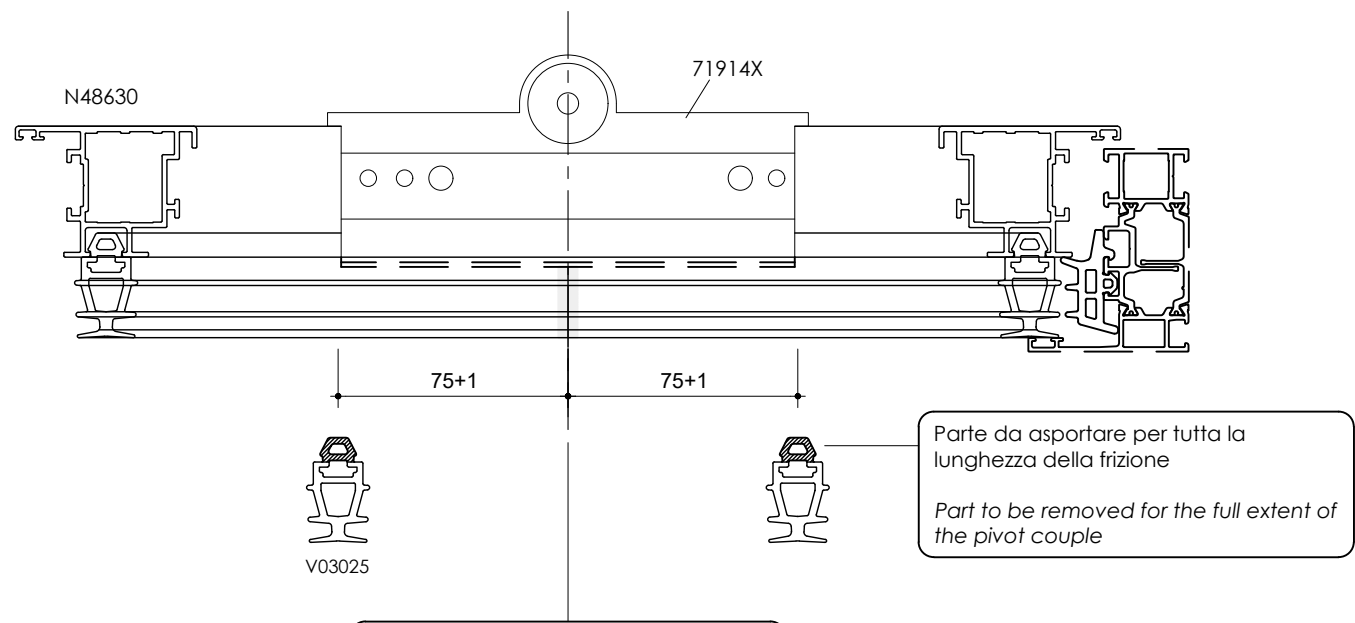
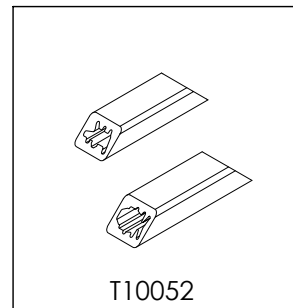
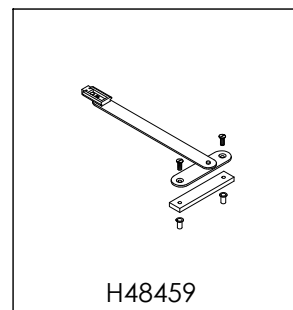
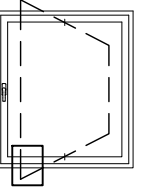

Nella zona di giunzione la guarnizione dovrà essere tagliata 2mm più lunga rispetto alla quota teorica
 In the joint section, the gasket shall be cut 2mm longer than the standard dimension

Per il taglio delle guarnizioni V02014 e V03025 utilizzare kit dime T10052
 To cut the V02014 and V03025 gaskets use the template kit T10052

REGOLAZIONE FRIZIONE art. 71914X
 PIVOT ADJUSTMENT art. 71914X

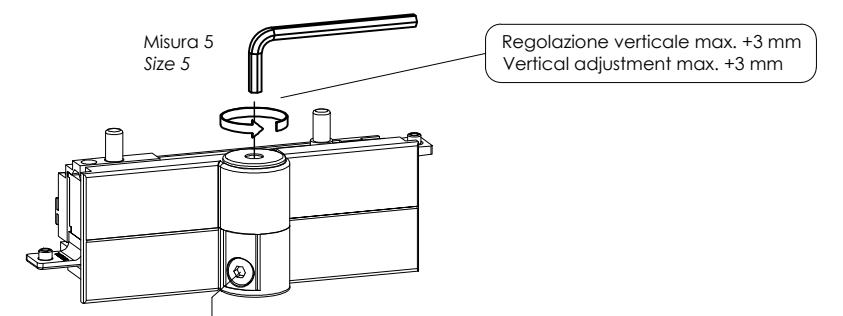

Regolare la resistenza alla rotazione in maniera equivalente su entrambe le frizioni
 Adjust sash frictions equally on either side with hexagonal Allen key size 5

Per il montaggio e lo smontaggio dell'anta allentare la vite utilizzando una chiave esagonale di misura 5 (la vite è assicurata contro lo sfilamento). La rimozione dell'anta è possibile ad un angolo di apertura compreso tra i 35° e 150°
 In order to hinge and unhinge the sash loosen the brake nipple screw using an hexagonal key size 5 (screw is secured against falling out). Hinging and unhinging is possible at an opening angle between 35° and 150°

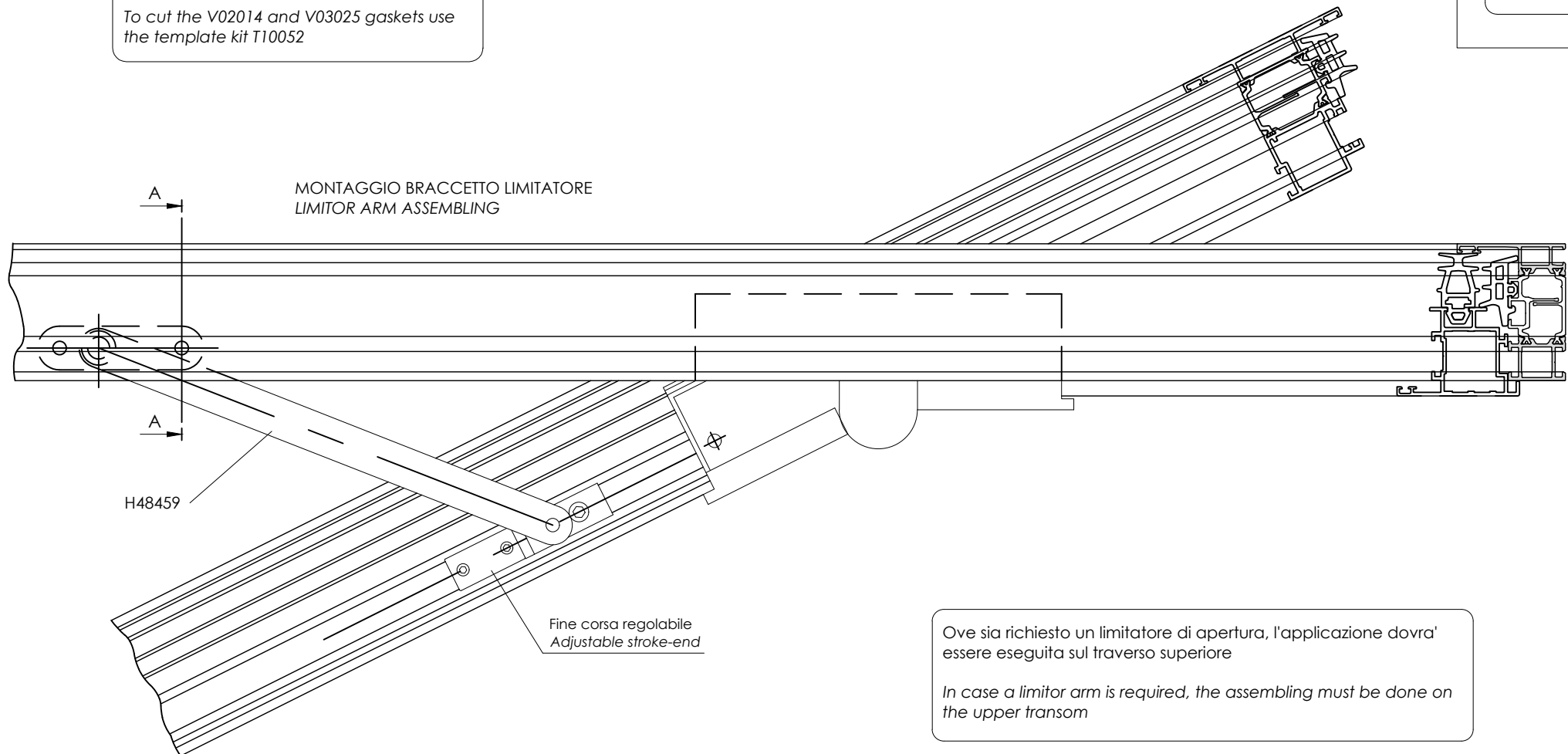

Ove sia richiesto un limitatore di apertura, l'applicazione dovrà essere eseguita sul traverso superiore
 In case a limiter arm is required, the assembling must be done on the upper transom

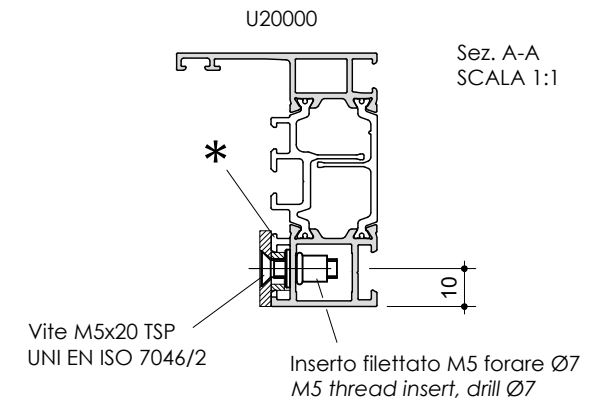

Asportazione in funzione della pinza tiraviti a disposizione
 * Removal depending on the tool available

SCHEMA DI MONTAGGIO ACCESSORI PER BILICO VERTICALE
 VERTICAL PIVOTING WINDOW HARDWARE ASSEMBLING DIAGRAM

C67K	C77K	C77K-CS
●		

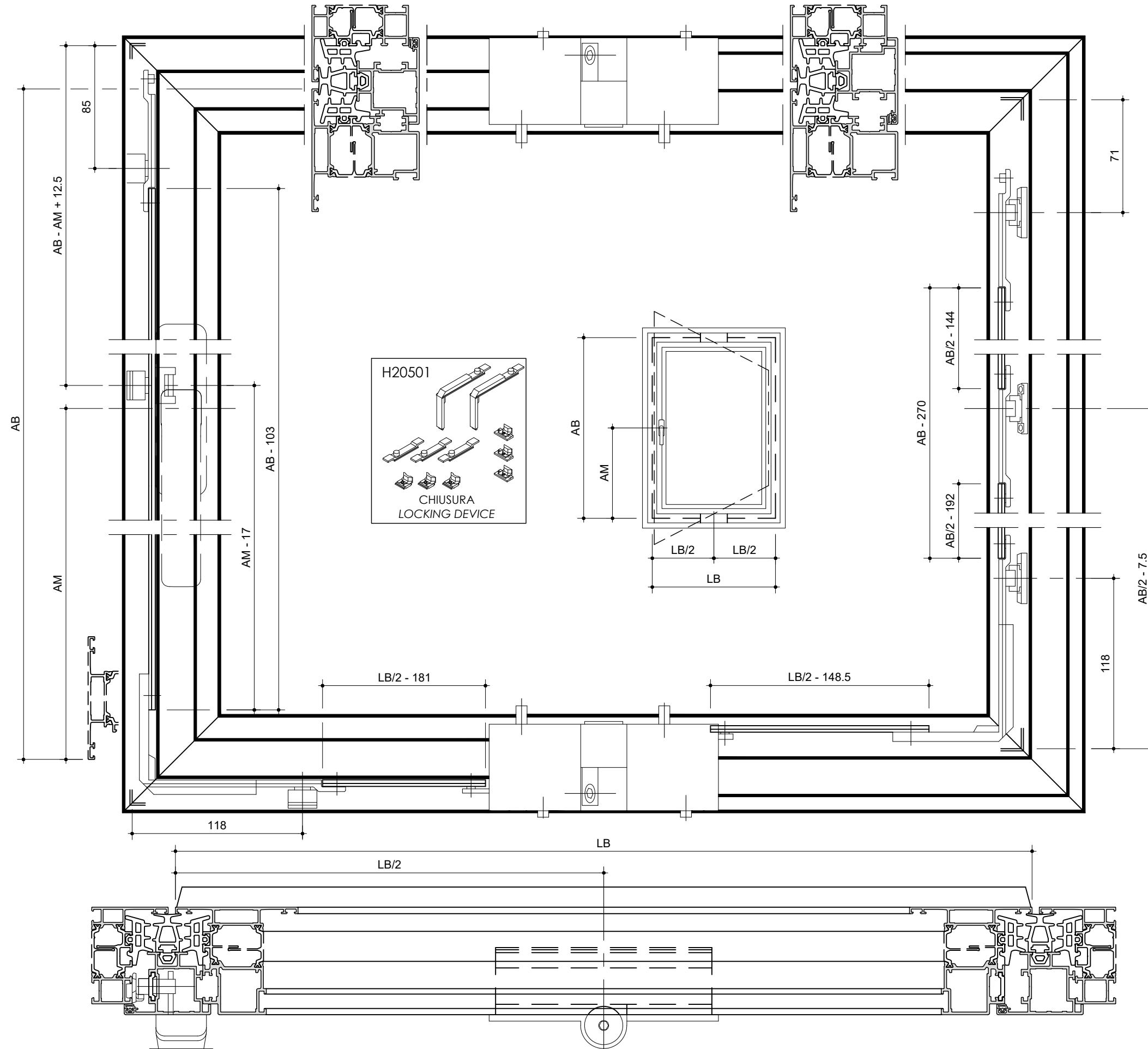
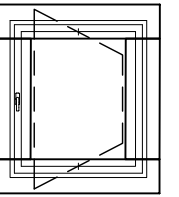

AluK (IT)

Via Monte Amiata, 3/a
37057 - S. Giovanni Lupatoto
Verona - ITALY

T:+39 045 9696611

info.it@aluk.com